

DEA



SECURITY®



PRODUCT CATALOGUE 2024

Edition January 2024 - v. 1.2.0

SERIE A03 PRO **page 8**

Piezodynamic detector for windows and door with magnetic contact (SN-A03P-DRM) 9

Piezodynamic detector for windows and door (SN-A03P-DR) 10

Piezoceramic detector for burglar bars (SN-A03P-GR) 11

Piezodynamic detector for walls (SN-A03P-WL/WLT) 12

Glass-break detector (SN-A03P-GL) 13

Multi-zone electronic processing board (BR-A03P-Z4) 14

Wi-fi dongle for BR-A03P-Z4 (DG-DEA-WF2) 15

Interface board for SERIE A03 sensors (BR-A03P-ADP) 16

Connection cable (CB-A03P-2C100) 17

Service mobile app (SW-A03P-APP) 18

Application examples..... 19

SPC PRO **page 22**

Detector DSF for windows and door with magnetic contact (SN-SPCP-FDR1M)..... 23

Detector DSF for windows and doors (SN-SPCP-FDR1) 24

Detector DSF for windows and doors with magnetic contact (SN-SPCP-FDR2M) 25

Detector DSF for windows and doors (SN-SPCP-FDR2) 26

Detector DSF for walls and armoured structures (SN-SPCP-FWL1) 27

Detector DSF for walls and armoured structures (SN-SPCP-FWL2) **NEW**..... 28

Glass-break detector (SN-SPC-GL) 29

Wi-fi dongle for detectors (DG-DEA-WF2) 30

Fixing plate for SN-SPCP-FWLx (FP-FWL) 31

Spacers for SN-SPCP-FDRx sensors (SB-SPCP-FDR) 32

Spacers for magnetic contacts (MB-SPCP-FDR) 32

Service mobile app (SW-SPCP-APP)..... 33

XENSITY **page 34**

Detector DSF for windows and doors with magnetic contact (SN-XS-FDRxM)..... 35

Detector DSF for windows and doors (SN-XS-FDRx) 36

Module for burglar bars (MD-XS-GR)..... 37

Detector DSF for walls (SN-XS-FWL) 38

Controller board for 32 sensors (BR-XS-CTRL32) 39

Controller board for 64 sensors (BR-XS-CTRL64) 40

Peripheral analysis board (BR-XS-PU) 41

Interface peripheral board for SISMA CA/CA PF (BR-XS-SMCAPU) **NEW**..... 42

Interface peripheral board for third party devices (BR-XS-TPS)..... 43

16-relay expansion board (BR-XS-RE16L) 44

Connection cable (CB-XS)..... 45

Flexible metal tube for cable (MS-XS) 46

Fixing plate for SN-XS-FWL (FP-FWL)..... 47

Bases for SN-XS-FDRx sensors (SB-XS-DR) 48

Spacers for magnetic contacts (MB-XS-DR)..... 48

Spare parts..... 49

 Piezoceramic detector for MD-XS-GR (SN-XS-GR)..... 50

 Peripheral analysis board for MD-XS-GR (BR-XS-GR)..... 51

Application examples..... 52

FUSION P2P		page 55
Sensor-strings (LN-FSP2P)		56
Sensor-string with armoured cable (LN-FSP2P-A) NEW		57
Connection cable (CB-FSP2P)		58
Armoured cable (CB-FSP2P-A) NEW		59
Initial string connectorized cable (CBINL-FSP2P)		60
Initial string connectorized armoured cable (CBINL-FSP2PA) NEW		61
Connectorized junction (JDVP-FSP2P)		62
Connectorized termination (TDV-FSP2P)		63
Junction (JBX-P2P)		64
Termination (TBX-P2P)		65
Control Unit (CU-FSP2P)		66
Control Unit with isolator (CU-FSP2P-ISB) NEW		67
Control board "Lite" (BR-FSP2PLT-CTRL) NEW		68
Peripheral interface module (SC-P2P-IN1)		69
16-relay expansion board (BR-XS-RE16L)		70
<i>Spare parts</i>		71
Controller board (BR-FSP2P-CTRL)		72
Voltage regulator (BR-FSP2PLT-BST) NEW		73
Isolator (BR-P2P-ISB) NEW		74
Pair of easy-plug connectors (CN-FSP2P)		75
Sensor (SN-FSP2P)		76
Sensor with armoured cable (SN-FSP2P-A) NEW		77
<i>Application examples</i>		78

SERIR page 84

SERIR 50		page 85
Sensor-strings (LN-SR50)		86
Sensor (SN-SR50)		87
Sensor-strings with metal tube (LN-SR50-GM)		88
Sensor with metal tube (SN-SR50-GM)		89
Connection cable (CB-ST50)		90
Junction/Termination (JTBX-ST50)		91
Dual-zone processing board (BR-SR50-Z2)		92
4-zone processing board (BR-SR50-Z4)		93
1-relay expansion board (SC-ER1)		94
<i>Application examples</i>		95

SERIR COMPACT 50		page 99
Basic Module (MD-SRC50)		100
Expansion Module (MD-SRC50EXP)		101
1-relay expansion board (SC-ER1)		102
<i>Spare Parts</i>		103
Analysis Unit (UA-SRC50)		104
Processing board (SC-SRC50MAIN)		105
Expansion board (SC-SRC50EXP)		106
Transformer (SC-C50PW)		107
Wiring kit (KITCB-C50)		107
Sensor-strings (LN-SR50)		108

Connection cable (CB-ST50)	108
Sensor (SN-SR50)	109
<i>Application examples</i>	110

TORSUS

page 113

TORSUS 50

page 114

Sensor-strings (LN-TR50).....	115
Sensor (SN-TR50).....	116
Single sensor (SN-TR50-S)	117
Single sensor with termination (SN-TR50-ST)	117
Sensor-strings with metal tube (LN-TR50-GM)	118
Sensor with metal tube (SN-TR50-GM)	119
Connection cable (CB-ST50).....	120
Junction/Termination (JTBX-ST50)	121
Dual-zone processing board (BR-TR50-Z2)	122
4-zone processing board (BR-TR50-Z4)	123
1-relay expansion board (SC-ER1)	124
<i>Application examples</i>	125

TORSUS COMPACT 50

page 129

Basic Module (MD-TRC50)	130
Expansion Module (MD-TRC50EXP)	131
1-relay expansion board (SC-ER1)	132
<i>Spare Parts</i>	133
Analysis Unit (UA-TRC50)	134
Processing board (SC-TRC50MAIN)	135
Expansion board (SC-TRC50EXP).....	136
Transformer (SC-C50PW)	137
Wiring kit (KITCB-C50)	137
Sensor-strings (LN-TR50)	138
Connection cable (CB-ST50)	138
Sensor (SN-TR50)	139
<i>Application examples</i>	140

SISMA CP 50

page 143

Sensor-strings (LN-SMCP50)	144
Sensor (SN-SMCP50)	145
Connection cable (CV-SMCP50)	146
Initial string junction (JBX-SMCP50-ILT)	147
Intermediate junction (JBX-SMCP50).....	148
Termination (TBX-SMCP50)	149
Single-zone processing board (BR-SMCP50-Z1)	150
Dual-zone processing board (BR-SMCP50-Z2)	151
1-relay expansion board (SC-ER1)	152
<i>Application examples</i>	153

SISMA CA		page 156
Sensor-module (MD-SMCA)		157
Connection cable (CV-SMCA)		158
Junction (JBX-SMCA)		159
Termination (TBX-SMCA)		160
Single-zone processing board (BR-SMCA-Z1)		161
Controller board for BR-XS-SMCAPU (BR-XS-CTRL32) NEW		162
Controller board for BR-XS-SMCAPU (BR-XS-CTRL64) NEW		163
Interface peripheral board for SISMA CA/CA PF (BR-XS-SMCAPU) NEW		164
SMCA NET adapter board (BR-XS-SMCAPU-ADP) NEW		165
16-relay expansion board (BR-XS-RE16L) NEW		166
1-relay expansion board (SC-ER1)		167
<i>Application examples</i>		168
SISMA CA PF		page 173
Sensor-module (MD-SMCAPF)		174
Connection cable (CV-SMCA)		175
Junction (JBX-SMCA)		176
Termination (TBX-SMCAPF)		177
Single-zone processing board (BR-SMCA-Z1)		178
Controller board for BR-XS-SMCAPU (BR-XS-CTRL32) NEW		179
Controller board for BR-XS-SMCAPU (BR-XS-CTRL64) NEW		180
Interface peripheral board for SISMA CA/CA PF (BR-XS-SMCAPU) NEW		181
SMCA NET adapter board (BR-XS-SMCAPU-ADP) NEW		182
16-relay expansion board (BR-XS-RE16L) NEW		183
1-relay expansion board (SC-ER1)		184
<i>Application examples</i>		185
DEA NET		page 189
Controller board for Ethernet network (BR-DN-ETHCTRL)		190
Server board for Ethernet networks (SC-DN-ETHSRV)		191
Interconnection board (SC-DN-HTRPT)		192
Interconnection board with high insulation (SC-DN-HTRPTAS)		193
Input/output board (SC-DN-IO)		194
Input/output board with programmable logic (SC-DN-IOLP)		195
16-relay expansion board (BR-DN-RE16)		196
1-relay expansion board (SC-ER1)		197
Power supply unit with interface (AL-DN-DEAPW)		198
<i>Application examples</i>		199
SOFTWARE		page 202
DEA MAP DLL (SW-DM-DLL)		203
ETHERNET SHARER (SW-ETHSHR)		203
Plug-in for the integration with Milestone XProtect (SW-PLG-MLS)		203

ACCESSORIES	page 204
Self-locking tie-wraps (FPA)	205
Resin for junctions/terminations (RP)	205
Stabilized power supply unit for CU-FSP2P (AL-P2P-3024)	206
Stabilized linear power supply units (AL)	207
Backup battery for CU-FSP2P (BT-P2P-12V)	208
Backup battery for COMPACT systems (BT-C12)	208
Cabinet for CU-FSP2P (BOX-P2P)	209
Cabinet for COMPACT systems (BOX-C50)	209
Preassembled cabinets (AP-C)	210
Pole mount kit for BOX-P2P cabinets (CL-BOXP2P)	211
Pole mount kit for AP-C cabinets (CL-AP)	211
Instructions for the use and the installation of DEA Security PIDS.....	212
Introduction to “General Sales Conditions”	214
General Sales Conditions	215

CONTENTS

**LAYER1
FUSION P2P**

Protection of fences



**LAYER1
TORSUS 50**

Protection of palisade fences



**LAYER1
SERIR 50**

Protection of flexible fence



**LAYER4
SISMA CA PF**

SISMA CA PF

SISMA CA PF

Indoor protections



**LAYER4
SISMA CA PF**

Invisible protection for raised floors



**LAYER3
SISMA CA**

Invisible protection for flooring



**LAYER2
SISMA CP 50**

Invisible buried protection

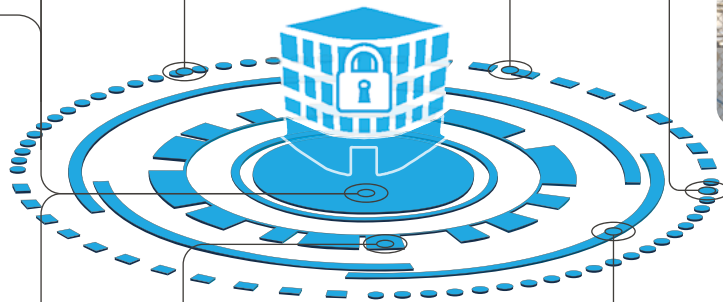

INDOOR SYSTEMS

SERIE A03 PRO

INDOOR SYSTEM WITH PROCESSING BOARD

SERIE A03 PRO is an intrusion detection system for the protection of windows, doors, glasses, walls and burglar bars. It is an evolution of the historical **SERIE A03** sensor range, which boasts tens of thousands installations in villas, banks, industrial buildings, police stations, shopping centres and luxury shops.

SERIE A03 PRO employs the proven detection technology of its predecessor, whose performance is still very high, but adds new features such as the **identification of the single structure under alarm, the configuration of the system from mobile app** and the native support to the star topology, which is the most widespread in home and business electric systems.

DEA Security has designed SERIE A03 PRO as a line of **specialized detectors**: each sensor protects a specific type of structure, where it provides the maximum performance without compromise. SERIE A03 PRO offers four detectors: **SN-A03P-DR(M)**, for the protection of windows and doors against burglary, breakthrough and opening; **SN-A03P-GL**, for the protection of glazed surfaces against break, breakthrough and drilling; **SN-A03P-GR**, for the protection of burglar bars against cut, break or breakthrough; and **SN-A03P-WL**, for the protection of walls against breakthrough and drilling.

All the SERIE A03 PRO sensor models are managed by a single electronic analysis board **BR-A03P-Z4**, which processes the signals coming from the sensors and generates the alarm states (if any) differentiating them by type of attack. The board is equipped with **4 independent channels to which up to 8 sensors can be connected**, two by channel. Each channel employs detection algorithms which are specific for the sensor models connected to it and **provides distinct signals**: thanks to this feature you can configure the system to identify the single structure under alarm.

PIEZODYNAMIC DETECTOR FOR WINDOWS AND DOORS WITH MAGNETIC CONTACT

PART NUMBER

SN-A03P-DRM



Piezodynamic shock detector to protect windows and doors against shocks, opening and breakthrough attempts. Door, window or skylight frame mounted, its high detection capability enables it to protect the whole structure, including glasses.

The sensor is equipped with magnetic contact which detects the opening of the structure and with an antiremoval device which signals the attempts of removing the sensor from the protected structure.

COMPLIANCE

IF CONNECTED TO BR-A03P-Z4:

- **Directive 2014/30/EU (EMC)**
 - EN 50130-4:2011
 - EN 61000-6-3:2007+A1:2011
- **Directive 2011/65/EU (RoHS)**
 - EN 50581:2012
- **Standard EN 50131-1:2006+A1:2009**
 - EN 50130-5:2011
 - EN 50131-2-6:2008



TECHNICAL FEATURES

- **Security grade:** Grade 3 certified
- **Environmental class:** Class II certified
- **Dimensions**
 - **sensor:** 31 x 51 x 19 mm (W x H x D)
 - **magnet:** 11 x 42 x 11 mm (W x H x D)
- **Gross weight:** 93 g
- **Net weight:** 73 g
- **Material:** ABS
- **Colour:** white
- **Operating temperature:**
 - -20 °C ÷ +70 °C non certified
 - -10 °C ÷ +40 °C (75% H.R.) certified
- **Relative humidity:** <95% non condensing
- **IP rating:** IP40
- **Functions and devices:**
 - antiremoval device
 - magnetic contact for opening detection
- **Connections:** 2 non-polarized conductors + shield
- **Average coverage area*:** 4 m²
- **Configuration by APP A03 PRO**

* Can vary depending on the dimensions, the material and the type of structure.



SN-A03P-DRM detector must be connected to BR-A03P-Z4 processing board by means of CV-A03P connection cable.



The sensor must be installed to the window/door frame whilst the magnetic contact to the hinged door/window.

PART NUMBER	DESCRIPTION	COLOUR
SN-A03P-DRM	Piezodynamic shock detector for windows and doors with magnetic contact	WHITE

PIEZODYNAMIC DETECTOR FOR WINDOWS AND DOORS

PART NUMBER

SN-A03P-DR



Piezodynamic shock detector for the protection of doors and windows against shocks and breakthrough attempts. Door, window or skylight frame mounted, its high detection sensitivity enables it to protect the whole door or window, including the glasses.

The sensor is equipped with an antiremoval device which signals the removal of the sensor from the structure.

COMPLIANCE

IF CONNECTED TO BR-A03P-Z4:

- **Directive 2014/30/EU (EMC)**
 - EN 50130-4:2011
 - EN 61000-6-3:2007+A1:2011
- **Directive 2011/65/EU (RoHS)**
 - EN 50581:2012

TECHNICAL FEATURES

- **Dimensions:** 31 x 51 x 19 mm (W x H x D)
- **Gross weight:** 82 g
- **Net weight:** 66 g
- **Material:** ABS
- **Colour:** white
- **Operating temperature:** -25 °C ÷ +70 °C
- **Relative humidity:** <95% non condensing
- **IP rating:** IP40
- **Functions and devices:** antiremoval device
- **Connections:** 2 non-polarized conductors + shield
- **Average coverage area*:** up to 4 m²
- **Configuration by APP A03 PRO**

* Can vary depending on the dimensions, the material and the type of structure.



SN-A03P-DR detector must be connected to BR-A03P-Z4 processing board by means of CV-A03P connection cable.



The sensor must be installed to the window/door frame.

PART NUMBER	DESCRIPTION	COLOUR
SN-A03P-DRM	Piezodynamic shock detector for windows and doors	WHITE

PIEZOCERAMIC DETECTOR FOR BURGLAR BARS

PART NUMBER

SN-A03P-GR



Piezoceramic shock detector for the protection of burglar bars against break and breakthrough attempts. Designed for outdoor use, the sensor is provided with metal housing and the relevant connection cable is protected by flexible metal tube.

COMPLIANCE

IF CONNECTED TO BR-A03P-Z4:

- **Directive 2014/30/EU (EMC)**
 - EN 50130-4:2011
 - EN 61000-6-3:2007+A1:2011
- **Directive 2011/65/EU (RoHS)**
 - EN 50581:2012

TECHNICAL FEATURES

- **Dimensions:** 33 x 100 x 14 mm (W x H x D)
- **Gross weight:** 326 g
- **Net weight:** 305 g
- **Material:** Zamak metal alloy
- **Colour:** grey
- **Operating temperature:** -25 °C ÷ +70 °C
- **Relative humidity:** <95% non condensing
- **IP rating:** IP55
- **Connections:** 2 non-polarized conductors + shield protected by flexible galvanized steel conduit with double seam and PVC coating (Ø 10 mm)
- **Average coverage area*:** 4 m²
- **Configuration by APP A03 PRO**

* Can vary depending on the dimensions, the material and the type of structure.



SN-A03P-GR sensor must be connected to BR-A03P-Z4 processing board by means of CV-A03P connection cable.



The sensor only protects the surface to which it is fixed.

PART NUMBER	DESCRIPTION	COLOUR
SN-A03P-GR	Piezoceramic shock detector for burglar bars	GREY



Piezodynamic shock sensor for the protection of walls against breakthrough and drilling.

The sensor is available both in an **internally balanced version** (P/N SN-A03P-WL) and in an **unbalanced version** (P/N SN-A03P-WLT).

The BR-A03P-Z4 analysis board can manage up to 2 SN-A03P-WL sensors per single channel (for a total of 8 balanced sensors per single board) and up to 10 SN-A03P-WLT sensors per single channel (for a total of 40 unbalanced sensors per single board distributed on 4 terminated detection lines).

COMPLIANCE

IF CONNECTED TO BR-A03P-Z4:

- **Directive 2014/30/EU (EMC)**
 - EN 50130-4:2011
 - EN 61000-6-3:2007+A1:2011
- **Directive 2011/65/EU (RoHS)**
 - EN 50581:2012

TECHNICAL FEATURES

- **Dimensions:** 41 x 67 x 27 mm (W x H x D)
- **Gross weight:** 50 g
- **Net weight:** 46 g
- **Material:** ABS
- **Colour:** white
- **Operating temperature:** -25 °C ÷ +70 °C
- **Relative humidity:** <95% non condensing
- **IP rating:** IP40
- **Functions and devices:**
 - detector removal device
 - detector opening device
- **Connections SN-A03P-WL:**
 - 2 non-polarized conductors + shield
- **Connections SN-A03P-WLT:**
 - 2 non-polarized conductors (input)
 - 2 non-polarized conductors (output)
 - shield
- **Average coverage area*:** 9 m²
- **Configuration by APP A03 PRO**

* Can vary depending on the dimensions, the material and the type of structure.



SN-A03P-WL/WLT sensor must be connected to BR-A03P-Z4 processing board by means of CV-A03P cable.



Each SN-A03P-WLT detector is supplied with an EOL resistor to be inserted into the last sensor of a line.

PART NUMBER	DESCRIPTION	COLOUR
SN-A03P-WL	Piezodynamic shock detector for walls	WHITE
SN-A03P-WLT	Piezodynamic shock detector for walls - for terminated lines version	WHITE



Piezoceramic shock sensor to protect glazed surfaces against break, drilling and breakthrough attempts. Easy and quick to install, the sensor is fixed to glass by means of the adhesive tape provided with it.

COMPLIANCE

IF CONNECTED TO BR-A03P-Z4:

- **Directive 2014/30/EU (EMC)**
 - EN 50130-4:2011+A1:2014
 - EN 61000-6-3:2007+A1:2011
- **Directive 2011/65/EU (RoHS)**
 - EN 50581:2012

TECHNICAL FEATURES

- **Dimensions:** 27 x 48 x 9 mm (W x H x D)
 - **Gross weight:** 63 g
 - **Net weight:** 54 g
 - **Material:** ABS
 - **Colour:** white
 - **Operating temperature:** -25 °C ÷ +70 °C
 - **Relative humidity:** <95% non condensing
 - **IP rating:** IP55
 - **Connections:** 2 non-polarized conductors + shield
 - **Average coverage area*:**
 - 4 m² on tempered glass (single layer) up to 11 mm thick
 - 3 m² reinforced glass (double layer) up to 11 mm thick
 - 2 m² reinforced glass (triple layer) up to 26 mm thick
 - **Configuration by APP A03 PRO**
- * Can vary depending on the dimensions, the material and the type of structure.



SN-A03P-GL detector must be connected to BR-A03P-Z4 processing board by means of CV-A03P connection cable.



The sensor only protects the surface to which it is fixed.

PART NUMBER	DESCRIPTION	COLOUR
SN-A03P-GL	Piezoceramic shock detector for glasses	WHITE

MULTI-ZONE ELECTRONIC PROCESSING BOARD

PART NUMBER

BR-A03P-Z4

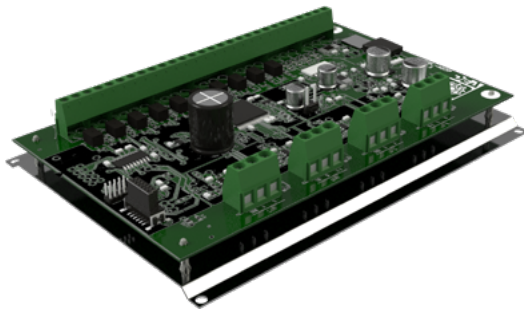

Multi-zone digital processing board to manage all SERIE A03 PRO sensor models. It processes the signals coming from the detectors and generates alarm states. The service app displays the alarms differentiating them by type of attack: shock (low shocks), breakthrough (gross attacks), drilling (continuous shocks).

The processing board is provided with 4 channels: each channel accepts up to 2 sensors of the same type, for a total amount of 8 sensors. The only exception is represented by

SN-A03P-WLT unbalanced detector of which the concerned board can manage – on each channel- terminated lines with max 10 sensors. On the BR-A03P-Z4 board 10 solid state NC outputs are available for the connection of the system to a control panel. To enter the configuration and calibration functions of the processing board, you need the DG-DEA-WF2 Wi-Fi dongle (see page 15) and the relevant service app for mobile devices (Android and iOS).

COMPLIANCE

IF CONNECTED TO SERIE A03 PRO DETECTORS:

- **Directive 2014/30/EU (EMC)**
 - EN 50130-4:2011
 - EN 61000-6-3:2007+A1:2011
- **Directive 2011/65/EU (RoHS)**
 - EN 50581:2012
- **Standard EN 50131-2-6+A1:2009**
 - EN 50131-2-6:2008



TECHNICAL FEATURES

- **Security grade:** Grade 2 certified (EN 50131-2-6:2008 if connected to SN-A03P-DRM)
- **Dimensions:** 130 x 104 x 32 mm (W x H x D)
- **Packaging dimensions:** 130 x 105 x 40 mm (W x H x D)
- **Gross weight:** 152 g
- **Net weight:** 109 g
- **Power supply:** 12 Vdc (+/- 25%)
- **Current:**
 - 80 mA (standby)
 - 220 mA (max - during calibration)
- **Operating temperature:** -25 °C ÷ +70 °C (non certified)
- **Relative humidity:** <95% non condensing
- **Management capability:** 8 SERIE A03 PRO sensors (2 for each channel)
- **Inputs:**
 - 4 for A03 PRO sensors (2 non polarized conductors + shield for each channel)
 - 4 RESET (one per channel)
- **NC relay outputs:**
 - 4 Burglar/Breakthrough alarm outputs (one per channel)
 - 4 Opening alarm outputs (one per channel)
 - general tamper
 - low supply voltage/service activity/CPU failure
- **Communication port:** Wi-Fi Dongle DG-DEA-WF2
- **Mobile app licence (iOS/ANDROID) included**



BR-A03P-Z4 board must be installed inside a case protected against opening events.



The configuration and calibration of the detectors can be performed only after connecting the DG-DEA-WF2 dongle to the BR-A03P-Z4 processing board and installing the relevant service app on an Android or iOS mobile device.

PART NUMBER	DESCRIPTION
BR-A03P-Z4	Multi-zone electronic processing board

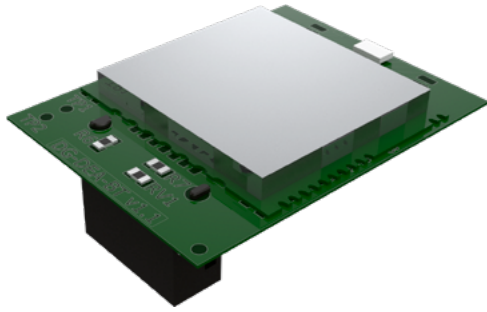

Wi-Fi module which connects to BR-A03P-Z4 processing board and activates its wireless functionalities. It allows you to configure and calibrate SERIE A03 PRO system from a tablet or an iOS/Android smartphone by means of the SW-A03P-APP mobile app (user licence included).

COMPLIANCE

IF CONNECTED TO BR-A03P-Z4:

- **Directive 2014/30/EU (EMC)**
 - › EN 50130-4:2011
 - › EN 61000-6-3:2007+A1:2011
- **Directive 2011/65/EU (RoHS)**
 - › EN 50581:2012
- **Directive 2014/53/EU (RED)**
 - › EN 301 489-17
 - › EN 300 328
- **WI-FI CERTIFIED™ B, G, N**
- **WPA™ - ENTERPRISE, PERSONAL**
- **WPA2™ - ENTERPRISE, PERSONAL**

TECHNICAL FEATURES

- **Dimensions:** 28 x 20 x 14 mm (W x H x D)
- **Gross weight:** 8 g
- **Net weight:** 4 g
- **Power supply:** by means of BR-A03P-Z4 board
- **Operating temperature:** -25 °C ÷ +70 °C
- **Relative humidity:** <95% non condensing
- **Wi-Fi authentication:** WPA/WPA2
- **Standard:** IEE 802.11 B/G/N WI-FI



The configuration and calibration of the detectors can be performed only after connecting DG-DEA-WF2 dongle to BR-A03P-Z4 processing board and after installing the relevant service app on an Android or iOS mobile device.



When service operations are over, the dongle must be disconnected from the processing board.

PART NUMBER	DESCRIPTION
DG-DEA-WF2	Wi-Fi dongle for BR-A03P-Z4 processing board

INTERFACE BOARD FOR SERIE A03 SENSORS

PART NUMBER

BR-A03P-ADP

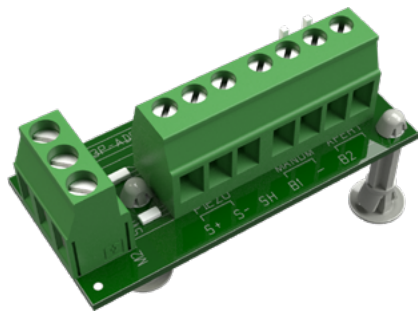

Passive interface board which allows you to integrate SERIE A03 sensors into the new SERIE A03 PRO system. The interface is equipped with two terminal boards: one for the connection of SERIE A03 4/6 conductor sensors (plus shield) and one for the connection to an available channel of the BR-A03P-Z4 processing board.

COMPLIANCE

IF CONNECTED TO BR-A03P-Z4:

- **Directive 2014/30/EU (EMC)**
 - EN 50130-4:2011+A1:2014
 - EN 61000-6-3:2007+A1:2011
- **Directive 2011/65/EU (RoHS)**
 - EN 50581:2012

TECHNICAL FEATURES

- **Dimensions:** 45 x 27 x 21 mm (W x H x D)
- **Gross weight:** 18 g
- **Net weight:** 15 g
- **Operating temperature:** -25 °C ÷ +70 °C (non certified)
- **Relative humidity:** <95% non condensing
- **Management capability:** maximum 6 SERIE A03 sensors
- **Inputs:**
 - 1 piezo line (2 conductors + shield)
 - 2 balanced lines (tamper and/or opening)
- **Outputs:** channel BR-A03P-Z4 (2 polarized conductors + shield)



It is possible to connect up to 6 SERIE A03 sensors of the same model to BR-A03P-ADP board.



BR-A03P-Z4 board can manage, on different channels, mixed configurations of BR-A03P-ADP interfaces and SERIE A03 PRO sensors.

A03 PRO

PART NUMBER	DESCRIPTION
BR-A03P-ADP	Interface board for SERIE A03 sensors



2-conductor shielded cable for the connection of A03 PRO sensors to BR-A03P-Z4 processing board. Compliant with CEI-UNEL 36762, it is suitable for fixed installations in buildings and other civil engineering works subject to reaction-to-fire requirements.

COMPLIANCE

- CEI 20-11, CEI-UNEL 36762, CEI 20-22 II, CEI EN 60032-3-22 cat. A, CEI 20-35-1-2
- EN 50363, EN 50575:2014+A1:2016
- IEC 60332-3-22 cat. A, IEC 60332-1-2
- Directive 2014/35/EU, Directive RoHS 2011/65/EU

TECHNICAL FEATURES

- **Nominal weight:** 32 Kg/Km
- **Nominal diameter:** 4.40 +/- 0.2 mm
- **Conductors:** tinned copper twisted pair and shield
- **Insulation:** special flame retardant PVC compound (quality R2-TI2 - CEI 20-11, EN 50363)
- **Cross sectional area:** 0.22 mm²
- **Lay up:** in round shape
- **Shield:** Polyester-Aluminium foil tape (coverage >100%), with tinned copper drain wire cross sectional area (sect. 0.14 mm²)
- **Jacket:** special flame retardant PVC compound (quality TM2-RZ - CEI 20-11, EN 50363)
- **Colour:** white
- **Maximum DC conductor resistance:**
 - 94.2 Ω/Km at 20 °C (sect. 0.22 mm²)
 - 150 Ω/Km at 20 °C (sect. 0.14 mm²)
- **Working voltage:** 50 Vac, 120 Vdc
- **Test voltage:** 500 Vac (1.000 Vdc)
- **Outer jacket test voltage:** 2.000 Vac (CEI-UNEL 36762)
- **Insulation voltage:** 0.6/1kV (outwards)
- **Bending radius:** 15 times outer diameter
- **Operating temperature:**
 - -40 ÷ +80 °C (fixed installation)
 - -15 ÷ +80 °C (mobile installation)
- **Installation temperature:** -15 ÷ +50 °C
- **Short circuit temperature:** max 150 °C
- **Use:** suitable for being installed in a grouping of cables with nominal voltage U₀/U 0.6/1kV max
- **Special features:** fire retardant cables CEI 20-22/II, EN 60332-3-22, IEC 60332-3-22 (IEC 60332.3A)
- **Class reaction to fire:** Eca (EN 50575: 2014+A1:2016. In compliance with annex III Regulation UE N. 305/2011)



The overall length of CB-A03P cable connecting A03 PRO to the relevant analysis board must not be more than 100 metres each channel.

PART NUMBER	DESCRIPTION	COLOUR
CB-A03P-2C100	Connection cable - 100 m reel	WHITE



Mobile app developed by DEA Security to operate with DG-DEA-WF2 dongle connected to BR-A03P-Z4 processing board. This app enables you to configure and calibrate SERIE A03 PRO detectors by using a Wi-Fi secure connection. For each channel, you can activate/deactivate the desired protections (low shocks, gross attacks and continuous shocks), set up the number of events needed to trigger an alarm, set up the memory time for the event counting and calibrate the detection sensitivity. Explicative icons show real-time alarm states differentiated by prealarm, tamper, opening, low shocks, continuous shocks and gross attacks. A graphic bar also shows the real-time signal intensity perceived by the sensor.

MINIMUM REQUIREMENTS

Android operating system: version 4.1.1 and the following iOS operating system (Apple): version 10.1 and the following



It is possible to use the service app only after connecting DG-DEA-WF2 dongle to BR-A03P-Z4 processing board.



The app software licence is included in the DG-DEA-WF2 dongle.

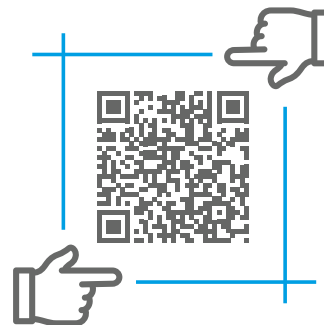
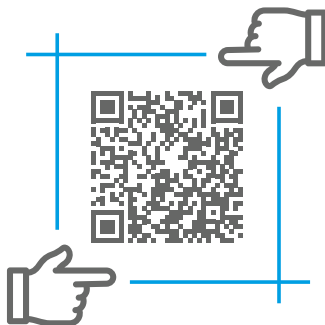

PART NUMBER	DESCRIPTION
SW-A03P-APP	Service mobile app to be used with DG-DEA-WF2

APPLICATION EXAMPLES

TYPICAL CONFIGURATION OF THE SYSTEM

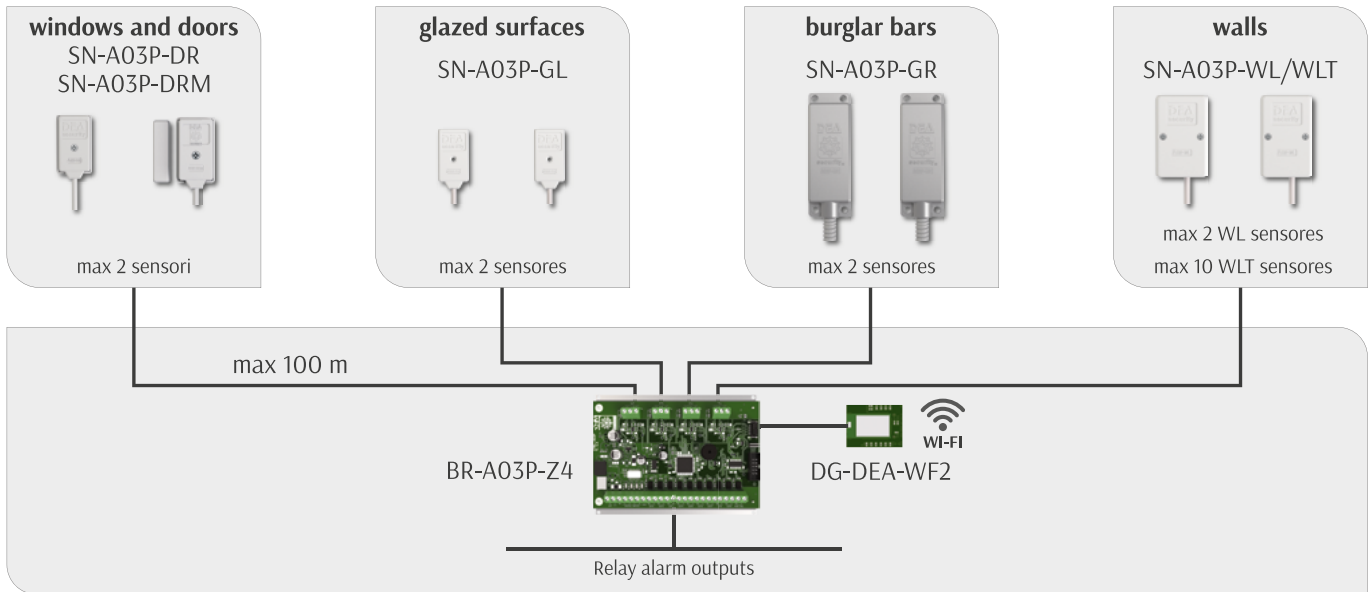

EXAMPLE OF PROTECTION OF A COMMERCIAL BUILDING

The protection of a single-storey building is assumed here. Below you can find the list of the structures to be protected and the relevant sensors used.

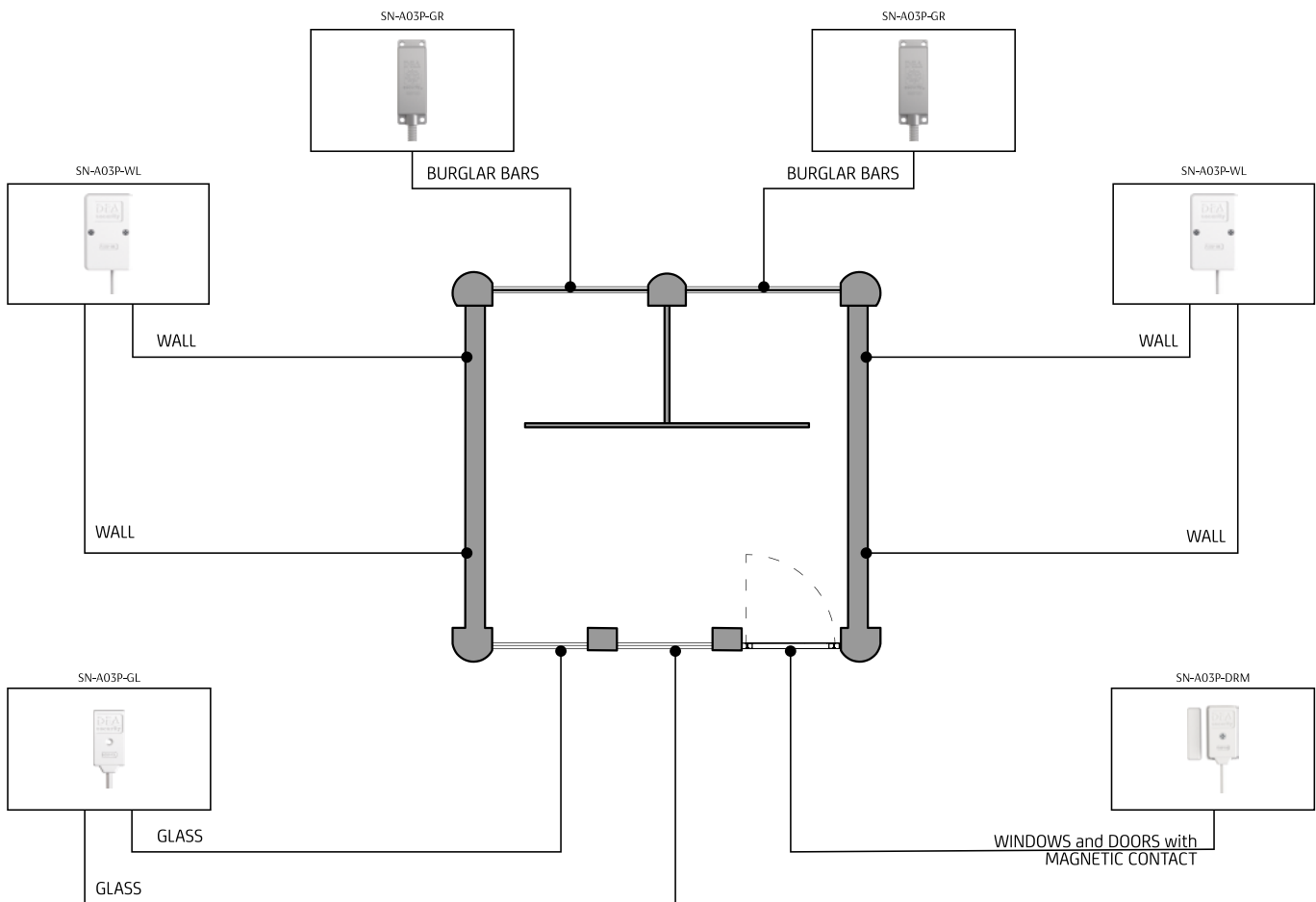

STRUCTURE TO PROTECT	SOLUTION
1 single frontdoor	1 SN-A03P-DRM detector on the door or window frame
2 windows with burglar bars	1 SN-A03P-GR detector on each burglar bar
2 glass windows of approx. 6m ² each	2 SN-A03P-GL detector for each window glass
2 perimeter walls of approx. 6m each	2 SN-A03P-WL detector on each wall

List of parts to make a system as per the previous example:

Q.TY	PART NUMBER	DESCRIPTION
1	SN-A03P-DRM	Piezodynamic detector for windows and doors with magnetic contact
2	SN-A03P-GR	Piezoceramic detector for burglar bars
4	SN-A03P-GL	Piezoceramic detector for glasses
4	SN-A03P-WL	Piezodynamic detector for walls
2	BR-A03P-Z4	Multi-zone electronic processing board
1	CB-A03P-2C100	2-connection cable - 100m reel
1	DG-DEA-WF2	Wi-Fi dongle for BR-A03P-Z4 processing board
1	SW-A03P-APP	Service mobile app to be used with DG-DEA-WF2

INDOOR SYSTEMS

SPC PRO

INDOOR DUAL-TECH STAND-ALONE DETECTORS

SPC PRO is a range of stand-alone indoor intrusion detectors. It employs the **DEA Sensor Fusion (DSF)** detection technology to protect windows, doors and walls against break-in attempts. Depending on the model, SPC PRO detectors are employed on **doors, windows, skylights** and **different types of walls**, including masonry and reinforced concrete walls.

SPC PRO detectors perceive the impacts and the vibrations generated by attempts of **forcing, breaking through** or **perforating the protected structure**. They employ two different sensitive elements: a well-proven **PIEZOELECTRIC transducer** and a **MEMS accelerometer**. The signals received by each transducer are fused and processed using **Intelligent Adaptive Algorithms**: such algorithms enhance the key benefits of both of the technologies to obtain an unmatched reliability.

The system is composed of **four detector models**: two for doors and windows (each of them available with or without magnetic contact), one for walls and one for glazed surfaces. Being stand-alone, the four detectors do not need any separate processing board.

DSF DETECTOR FOR WINDOWS AND DOORS WITH MAGNETIC CONTACT

PART NUMBER

SN-SPCP-FDR1M



Dual-tech shock detector equipped with magnetic contact for the protection of windows and doors against burglary, breaking through, drilling and opening events. It can be installed at any inclination and orientation and to be fixed to door, window or skylight frames, its elevated detection sensitivity enable it to protect the whole structure, including glass (if any). The detector employs tamper devices to signal sensor removal, magnetic masking and case opening. Configurations and calibrations are performed via service app for Android and iOS mobile devices.

COMPLIANCE

- **Directive 2014/30/EU (EMC)**
 - › EN 50130-4:2011+A1:2014
 - › EN 61000-6-3:2007+A1:2011
- **Directive 2011/65/EU (RoHS)**
 - › EN 50581:2012
- **Standard EN 50131-1:2006+A1:2009+A2:2017**
 - › EN 50131-2-6:2008
 - › EN 50131-2-8:2016



TECHNICAL FEATURES

- **Security grade:** Grade 3 certified (EN 50131-2-6 and EN 50131-2-8)
- **Environmental class:** Class II certified
- **Dimensions:**
 - **sensor:** 89 x 26 x 20 mm (W x H x D)
 - **magnet:** 53 x 10 x 12 mm (W x H x D)
- **Packaging dimensions:** 110 x 75 x 35 mm (W x H x D)
- **Gross weight:** 72 g
- **Net weight:** 53 g
- **Material:** ABS
- **Colour:** white
- **Power supply:**
 - 12 Vdc (± 25% - nominal)
 - 8 Vdc (low supply voltage)*
 - 15,5 Vdc (high supply voltage)*
- **Current:** 25 mA - 60 mA max (during calibration)
- **Operating temperature:** -20 °C ÷ +70 °C non certified
- **Relative humidity:** <95% non condensing
- **IP rating:** IP40
- **Functions and devices:**
 - anti-removal tamper
 - anti-opening tamper
 - magnetic anti-masking tamper
 - low supply voltage signal*
- **Inputs:**
 - Reset
 - ARM (for alarm memory)
- **Outputs (NC):**
 - alarm line (continuous vibrations, low attacks, gross attacks, heavy attacks) and low supply voltage*
 - magnetic contact opening
 - tamper
- **Communication:** DG-DEA-WF2 Wi-Fi dongle
- **Average coverage area:** 4 m²
- **Configuration via SPC PRO APP**
- **Mobile app licence (iOS/Android) included**

* Functions which are not EN 50131-2-8 certified.



The sensor must be installed on the door or window frame.



The configuration and calibration of the detector can be performed only after connecting the DG-DEA-WF2 dongle and installing the specific service app on an Android or IOS mobile device.

PART NUMBER	DESCRIPTION	COLOUR
SN-SPCP-FDR1M	DSF shock detector equipped with magnetic contact for doors and windows - with mobile app	WHITE

DSF DETECTOR FOR WINDOWS AND DOORS

PART NUMBER

SN-SPCP-FDR1



Dual-tech shock detector for the protection of doors and windows against burglary, breaking through and drilling events. It can be installed at any inclination and orientation and to be fixed to door, window or skylight frames, its elevated detection sensitivity enable it to protect the whole structure, including glass (if any).

The detector employs tamper devices to signal sensor removal and case opening attempts. Configurations and calibrations are performed via service app for Android and IOS mobile devices.

COMPLIANCE

- **Directive 2014/30/EU (EMC)**
 - EN 50130-4:2011+A1:2014
 - EN 61000-6-3:2007+A1:2011
- **Directive 2011/65/EU (RoHS)**
 - EN 50581:2012
- **Standard EN 50131-1:2006+A1:2009+A2:2017**
 - EN 50131-2-8:2016



TECHNICAL FEATURES

- **Security grade:** Grade 3 certified (EN 50131-2-8)
- **Environmental class:** Class II certified
- **Dimensions:** 89 x 26 x 20 mm (W x H x D)
- **Packaging dimensions:** 110 x 75 x 35 mm (W x H x D)
- **Gross weight:** 62 g
- **Net weight:** 46 g
- **Material:** ABS
- **Colour:** white
- **Power supply:**
 - 12 Vdc (± 25% - nominal)
 - 8 Vdc (low supply voltage)*
 - 15,5 Vdc (high supply voltage)*
- **Current:** 25 mA - 60 mA max (during calibration)
- **Operating temperature:**
 - -20 °C ÷ +70 °C non certified
 - -10 °C ÷ +40 °C (75% H.R.) certified
- **Relative humidity:** <95% non condensing
- **IP rating:** IP40
- **Functions and devices:**
 - anti-removal and anti-opening tamper
 - low supply voltage signal*
- **Inputs:**
 - Reset
 - ARM (for alarm memory)
- **Outputs (NC):**
 - alarm line (continuous vibrations, low attacks, gross attacks, heavy attacks) and low supply voltage*
 - tamper
- **Communication:** DG-DEA-WF2 Wi-Fi dongle
- **Average coverage area:** 4 m²
- **Configuration via SPC PRO APP**
- **Mobile app licence (iOS/Android) included**

* Functions which are not EN 50131-2-8 certified.



The sensor must be installed on the door or window frame.



The configuration and calibration of the detector can be performed only after connecting the DG-DEA-WF2 dongle and installing the specific service app on an Android or IOS mobile device.

PART NUMBER	DESCRIPTION	COLOUR
SN-SPCP-FDR1	DSF shock detector for doors and windows - with mobile app	WHITE

DSF DETECTOR FOR WINDOWS AND DOORS WITH MAGNETIC CONTACT

PART NUMBER

SN-SPCP-FDR2M



Dual-tech shock detector equipped with magnetic contact for the protection of doors and windows against burglary, breaking through, drilling and opening events. It can be installed at any inclination and orientation and to be fixed to door, window or skylight frames, its elevated detection sensitivity enable it to protect the whole structure, including glass (if any). The detector employs tamper devices to signal sensor removal and case opening attempts. Configurations and calibrations are performed via dip switches.

COMPLIANCE

- **Directive 2014/30/EU (EMC)**
 - EN 50130-4:2011+A1:2014
 - EN 61000-6-3:2007+A1:2011
- **Directive 2011/65/EU (RoHS)**
 - EN 50581:2012
- **Standard EN 50131-1:2006+A1:2009+A2:2017**
 - EN 50131-2-6:2008
 - EN 50131-2-8:2016



TECHNICAL FEATURES

- **Security grade:** Grade 2 certified (EN 50131-2-6)
Grade 3 certified (EN 50131-2-8)
- **Environmental class:** Class II certified
- **Dimensions**
 - **sensor:** 89 x 26 x 20 mm (W x H x D)
 - **magnet:** 53 x 10 x 12 mm (W x H x D)
- **Packaging dimensions:** 110 x 75 x 35 mm (W x H x D)
- **Gross weight:** 76 g
- **Net weight:** 57 g
- **Material:** ABS
- **Colour:** white
- **Power supply:**
 - 12 Vdc (± 25% - nominal)
 - 8 Vdc (low supply voltage)*
 - 15,5 Vdc (high supply voltage)*
- **Current:** 20 mA
- **Operating temperature:**
 - -20 °C ÷ +70 °C non certified
 - -10 °C ÷ +40 °C (75% H.R.) certified
- **Relative humidity:** <95% non condensing
- **IP rating:** IP40
- **Functions and devices:**
 - anti-removal and anti-opening tamper
 - low supply voltage signal*
- **Inputs:**
 - Reset
 - ARM (for alarm memory)
- **Outputs (NC):**
 - alarm line (continuous vibrations, low attacks and gross attacks) and low supply voltage*
 - magnetic contact opening
 - tamper
- **Average coverage area:** 4 m²

* Functions which are not EN 50131-2-8 certified.



The sensor must be installed on the door or window frame.

PART NUMBER	DESCRIPTION	COLOUR
SN-SPCP-FDR2M	DSF shock detector equipped with magnetic contact for doors and windows - with mobile app	WHITE

DSF DETECTOR FOR WINDOWS AND DOORS

PART NUMBER

SN-SPCP-FDR2



Dual-tech shock detector equipped with magnetic contact for the protection of doors and windows against burglary, breaking through, drilling and opening events. It can be installed at any inclination and orientation and to be fixed to door, window or skylight frames, its elevated detection sensitivity enable it to protect the whole structure, including glass (if any). The detector employs tamper devices to signal sensor removal and case opening attempts. Configurations and calibrations are performed via dip switches.

COMPLIANCE

- **Directive 2014/30/EU (EMC)**
 - EN 50130-4:2011+A1:2014
 - EN 61000-6-3:2007+A1:2011
- **Directive 2011/65/EU (RoHS)**
 - EN 50581:2012
- **Standard EN 50131-1:2006+A1:2009+A2:2017**
 - EN 50131-2-8:2016



TECHNICAL FEATURES

- **Security grade:** Grade 3 certified (EN 50131-2-8:2016)
- **Environmental class:** Class II certified
- **Dimensions:** 89 x 26 x 20 mm (W x H x D)
- **Packaging dimensions:** 110 x 75 x 35 mm (W x H x D)
- **Gross weight:** 62 g
- **Net weight:** 46 g
- **Material:** ABS
- **Colour:** white
- **Power supply:**
 - 12 Vdc (± 25% - nominal)
 - 8 Vdc (low supply voltage)*
 - 15,5 Vdc (high supply voltage)*
- **Current:** 20 mA
- **Operating temperature:**
 - -20 °C ÷ +70 °C non certified
 - -10 °C ÷ +40 °C (75% H.R.) certified
- **Relative humidity:** <95% non condensing
- **IP rating:** IP40
- **Functions and devices:**
 - anti-removal and anti-opening tamper
 - low supply voltage signal*
- **Inputs:**
 - Reset
 - ARM (for alarm memory)
- **Outputs (NC):**
 - alarm line (continuous vibrations, low attacks and gross attacks) and low supply voltage*
 - tamper
- **Average coverage area:** 4 m²

* Functions which are not EN 50131-2-8 certified.



The sensor must be installed on the door or window frame.

PART NUMBER	DESCRIPTION	COLOUR
SN-SPCP-FDR2	DSF shock detector for doors and windows	WHITE

SPCP PRO

DSF DETECTOR FOR WALLS AND ARMoured STRUCTURES

PART NUMBER

SN-SPCP-FWL1



Dual-tech seismic detector for the protection of walls and armoured structures against breaking, breaking through and drilling events. It can be installed at any inclination and orientation on different types of walls, including masonry, tuff, reinforced concrete and metal (e.g. vaults, safes and security cabinets). It employs tamper devices to signal sensor removal, thermal sabotage and case opening attempts.

Configurations and calibrations are performed via service app for Android and iOS mobile devices.

COMPLIANCE

- **Directive 2014/30/EU (EMC)**
 - EN 50130-4:2011+A1:2014
 - EN 61000-6-3:2007+A1:2011
- **Directive 2011/65/EU (RoHS)**
 - EN 50581:2012
- **Standard EN 50131-1:2006+A1:2009+A2:2017**
 - EN 50131-2-8:2016



TECHNICAL FEATURES

- **Security grade:** Grade 3 certified (EN 50131-2-8:2016)
- **Environmental class:** Class II certified
- **Dimensions:** 89 x 89 x 20 mm (W x H x D)
- **Packaging dimensions:** 90 x 130 x 35 mm (W x H x D)
- **Gross weight:** 72 g
- **Net weight:** 53 g
- **Material:** ABS
- **Colour:** white
- **Power supply:**
 - 12 Vdc (± 25% - nominal)
 - 8 Vdc (low supply voltage)**
 - 15,5 Vdc (high supply voltage)**
- **Current:** 20 mA - 50 mA max (during calibration)
- **Operating temperature:**
 - -20 °C ÷ +70 °C non certified
 - -10 °C ÷ +40 °C (75% H.R.) certified
- **Relative humidity:** <95% non condensing
- **IP rating:** IP40
- **Functions and devices:**
 - anti-removal and anti-opening tamper
 - thermal tamper
 - programmable periodic self-test**
 - functional test**
 - low supply voltage signal**
- **Inputs:**
 - functional test
 - ARM
- **Outputs (NC):**
 - alarm line (continuous vibrations, low attacks, gross attacks, heavy attacks), functional test, self-test failed and low supply voltage
 - tampers
- **Communication:** connector for Wi-Fi Dongle DG-DEA-WF2
- **Coverage area*:** up to 46 m² (custom mode)
- **Configuration via SPC PRO APP**
- **Mobile app licence (iOS/Android) included**

* Can vary depending on the dimensions, the material and the type of structure.

** Functions which are not EN 50131-2-8 certified.



The sensor can be fixed to the wall using the self-tapping screws and the plugs supplied. If the sensor is installed on irregular structures or on metal surfaces, the use of FP-FWL fixing plate is recommended.



The configuration and calibration of the detector can be performed only after connecting the DG-DEA-WF2 dongle and installing the specific service app on an Android or IOS mobile device.

PART NUMBER	DESCRIPTION	COLOUR
SN-SPCP-FWL1	DSF seismic sensor for walls and armoured structures - with mobile app	WHITE

DSF DETECTOR FOR WALLS AND ARMOURED STRUCTURES

PART NUMBER

SN-SPCP-FWL2



NEW



Dual-tech seismic detector for the protection of walls and armoured structures against breaking, breaking through and drilling events. It can be installed at any inclination and orientation on different types of walls, including masonry, tuff and reinforced concrete and metal (e.g. vaults, safes and security cabinets). It employs tamper devices to signal sensor removal, thermal sabotage and case opening attempts. Configurations and calibrations are performed via dip switch.

COMPLIANCE

- **Directive 2014/30/EU (EMC)**
 - EN 50130-4:2011+A1:2014
 - EN 61000-6-3:2007+A1:2011
- **Directive 2011/65/EU (RoHS)**
 - EN 50581:2012
- **Standard EN 50131-1:2006+A1:2009+A2:2017+A3:2020**
 - EN 50131-2-8:2016



TECHNICAL FEATURES

- **Security grade:** Grade 3 certified (EN 50131-2-8:2016)
- **Environmental class:** Class II certified
- **Dimensions:** 89 x 89 x 20 mm (W x H x D)
- **Packaging dimensions:** 90 x 130 x 35 mm (W x H x D)
- **Gross weight:** 72 g
- **Net weight:** 53 g
- **Material:** ABS
- **Colour:** white
- **Power supply:**
 - 12 Vdc (± 25% - nominal)
 - 8 Vdc (low supply voltage)**
 - 15,5 Vdc (high supply voltage)**
- **Current:** 20 mA
- **Operating temperature:**
 - -20 °C ÷ +70 °C non certified
 - -10 °C ÷ +40 °C (75% H.R.) certified
- **Maximum relative humidity:** <95% non condensing
- **IP rating:** IP40
- **Functions and devices:**
 - anti-removal and anti-opening tamper
 - thermal tamper
 - functional test**
 - periodic self-test**
 - low supply voltage signal**
- **Inputs:**
 - functional test
 - periodic self-test
- **Outputs (NC):**
 - alarm line (continuous vibrations, low attacks, gross attacks, heavy attacks), functional test, self-test failed and low supply voltage
 - tampers
- **Coverage area*:** up to 46 m² (custom mode)

* Can vary depending on the dimensions, the material and the type of structure.

** Functions which are not EN 50131-2-8 certified.



The sensor can be fixed to the wall using the self-tapping screws and the plugs supplied. If the sensor is installed on irregular structures or on metal surfaces, the use of FP-FWL fixing plate is recommended.

PART NUMBER	DESCRIPTION	COLOUR
SN-SPCP-FWL2	DSF seismic sensor for walls and armoured structures	WHITE



Piezoceramic shock detector for the protection of glass surfaces against breaking and breaking through. Fixed to glass by means of the adhesive tape supplied with it, it can be installed in any orientation.

The detector is equipped with anti-removal tamper, magnetic anti-masking function, resistive balance of the output lines and digital adjustment of the sensitivity on four levels (via dip switches).

COMPLIANCE

- **Directive 2014/30/EU (EMC)**
 - EN 50130-4:2011
 - EN 61000-6-3:2007+A1:2011
- **Directive 2011/65/EU (RoHS)**
 - EN 50581:2012

TECHNICAL FEATURES

- **Dimensions:** 45 x 43 x 15 mm (W x H x D)
- **Gross weight:** 63 g
- **Net weight:** 61 g
- **Material:** ABS
- **Colour:** white
- **Power supply:** 12 Vdc (± 25%)
- **Current:** 3 mA (stand by) - 6 mA (max)
- **Operating temperature:** 0 °C ÷ +70 °C
- **Relative humidity:** <95% non condensing
- **IP rating:** IP40
- **Functions and devices:** anti-removal tamper
- **Outputs:**
 - burglary and breaking through alarm
 - tamper line
- **Average coverage area:**
 - 3 m² (double layer glass, up to 11 mm thick)
 - 2 m² (reinforced glass, up to 26 mm thick)



The sensor must be installed on the door or window frame.

PART NUMBER	DESCRIPTION	COLOUR
SN-SPC-GL	Piezoceramic shock detector for glasses	WHITE

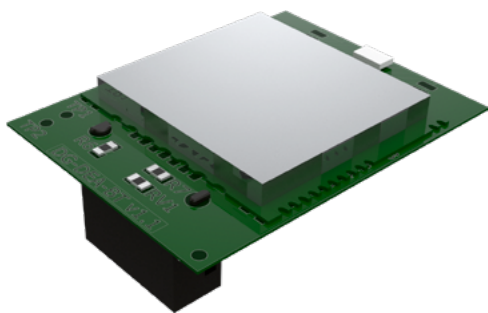

Wi-Fi dongle which connects to the electronic card of SN-SPCP-FDR1, SN-SPCP-FDR1M and SN-SPCP-FWL1 detectors and activates its wireless functionalities. It enables you to configure and calibrate each sensor from tablet or from an Android/IOS smartphone by means of SW-SPCP-APP free mobile app.

COMPLIANCE

IF CONNECTED TO SN-SPCP-FDR1, SN-SPCP-FDR1M AND SN-SPCP-FWL1 DETECTORS:

- **Directive 2014/30/EU (EMC)**
 - › EN 50130-4:2011
 - › EN 61000-6-3:2007+A1:2011
- **Directive 2011/65/EU (RoHS)**
 - › EN 50581:2012
- **Directive 2014/53/EU (RED)**
 - › EN 301 489-17
 - › EN 300 328
- **WI-FI CERTIFIED™ B, G, N**
- **WPA™ - ENTERPRISE, PERSONAL**
- **WPA2™ - ENTERPRISE, PERSONAL**

TECHNICAL FEATURES

- **Dimensions:** 28 x 20 x 14 mm (W x H x D)
- **Gross weight:** 8 g
- **Net weight:** 4 g
- **Power supply:** by means of SN-SPCP-FDR1(M)/SN-SPCP-FWL1
- **Operating temperature:** -25 °C ÷ +70 °C
- **Relative humidity:** <95% non condensing
- **Wi-Fi authentication:** WPA/WPA2
- **Standard:** IEE 802.11 B/G/N WI-FI



Calibration and configuration of SN-SPCP-FDR1(M) and SN-SPCP-FWL1 sensors can be performed only after having connected DG-DEA-WF2 dongle to the specific connector on the sensor and having installed the special service app on an iOS/Android mobile device.



At the end of service operations, the dongle must be disconnected from the sensor.

PART NUMBER	DESCRIPTION
DG-DEA-WF2	Wi-Fi dongle for detectors SN-SPCP-FDR1(M) and SN-SPCP-FWL1

FIXING PLATE FOR SN-SPCP-FWLx

PART NUMBER
FP-FWL

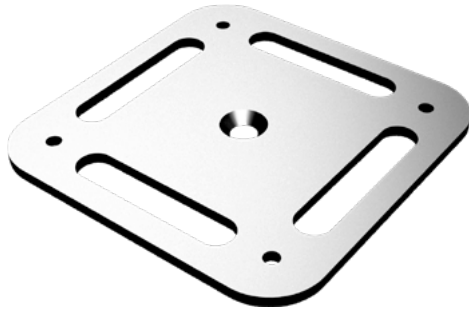

Stainless steel pre-drilled mounting plate to fix SN-SPCP-FWL1 and SN-SPCP-FWL2 sensors to wall or to ceiling. The fixing plate, suitable for being installed both on hollow-core concrete walls and on metal surfaces, simplifies the installation of the sensor and ensures its maximum performance.

TECHNICAL FEATURES

- **Dimensions:** 89 x 3 x 89 mm (W x H x D)
- **Net weight:** 136 g
- **Gross weight:** 166 g
- **Material:** stainless steel
- **Mounting:**
 - 4 holes for sensor fixing
 - 3 holes for wall or ceiling fixing
 - welding slot for metal surfaces

PACKAGE CONTENTS

- 1 plate
- 4 galvanized screws 4 x 8 mm TC+
- 1 galvanized screw 5 x 50 mm TS
- 1 nylon plug SX 8
- 4 M4 steel washers



The plate is equipped with holes for screws, with welding slots and with cable access hole.

PART NUMBER	DESCRIPTION	COLOUR
FP-FWL	Fixing plate for walls and ceilings	GREY

SPACERS FOR SN-SPCP-FDRx SENSORS

PART NUMBER
SB-SPCP-FDR



Spacers to be coupled with SN-SPCP-FDRx sensors. They are supplied in a pack containing 4 single colour pieces.

TECHNICAL FEATURES

- **Dimensions:** 90 x 26 x 4 mm (W x H x D)
- **Material:** ABS
- **Colour:** white

PART NUMBER	DESCRIPTION	PACKAGE	COLOUR
SB-SPCP-FDR	Spacers for SN-SPCP-FDRx sensors	4 pieces	WHITE

SPACERS FOR MAGNETIC CONTACTS

PART NUMBER
MB-SPCP-FDR

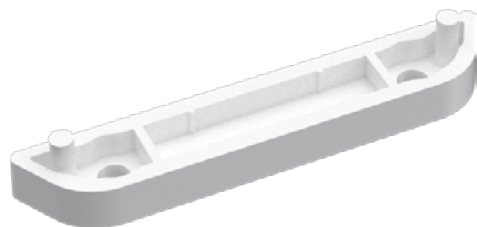

Spacers to be coupled with SN-SPCP-FDRxM sensors. They are supplied in a pack containing 4 single colour pieces.

TECHNICAL FEATURES

- **Dimensions:** 58 x 10 x 4 mm (W x H x D)
- **Material:** ABS
- **Colour:** white



It is possible to use on more spacers to install the magnetic contacts at the same height as the sensor.

PART NUMBER	DESCRIPTION	PACKAGE	COLOUR
MB-SPCP-FDRW	Spacers for magnetic contacts	4 pieces	WHITE



Mobile app developed by DEA Security to operate with DG-DEA-WF2 dongle connected to SN-SPCP-FDR1(M) and SN-SPCP-FWL1 detectors.

This app enables you to configure and calibrate these detectors using a Wi-Fi secure connection. For each channel, you can activate/deactivate the desired protections (continuous vibrations, low attacks, gross attacks, heavy attacks), set up the number of events needed to trigger an alarm, set up the memory time for the event counting and calibrate the detection sensitivity. Explicative icons show real-time alarm states differentiated by prealarm, tamper, opening, continuous vibrations, low attacks, gross attacks, heavy attacks, while a graphic bar displays the real-time signal intensity perceived by the sensor connected to the selected channel.

MINIMUM REQUIREMENTS

Android operating system: version 4.1.1 and the following

iOS operating system (Apple): version 10.1 and the following



The service app can be used only after connecting the DG-DEA-WF2 dongle to the detector to be configured.



The app software licence is included in the DG-DEA-WF2 dongle.

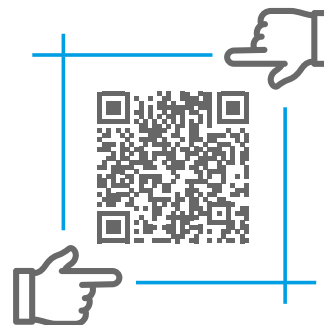
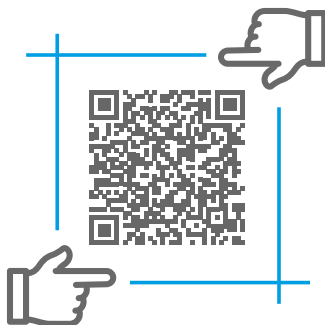

PART NUMBER	DESCRIPTION
SW-SPCP-APP	Service mobile app to be used with DG-DEA-WF2

INDOOR SYSTEMS

XENSITY

INDOOR POINT-ID SYSTEM

XENSITY is an intrusion detection system which has moved into the world of indoor security – houses, offices, banks and businesses – the same technologies developed by DEA Security for the outdoor perimeter protection of high risk compounds such as airports and power plants. Among those technologies we can mention the **DSF** (DEA Sensor Fusion), the **sensor self-test**, the **centralization** of the alarm signals and the **remote management** of the system over IP.

Currently XENSITY product line is composed of three sensor models: **SN-XS-FDRx(M)** for the **protection of doors and windows** against burglary, breaking through (the last one for the version equipped with magnet) and opening; **MD-XS-GR**, for the **protection of burglar bars** against cutting and breaking through; **SN-XS-FWL**, for the **protection of walls** against breaking, breaking through and drilling.

XENSITY detectors are all “addressable”, making it possible to **pinpoint an alarm**, and are equipped with DSF technology, **DEA’s international patent, which couples the piezoelectric transducer with a MEMS accelerometer**. The signals received by each transducer are fused and processed using **intelligent adaptive** algorithms: such algorithms enhance the key benefits of both the technologies to reach the highest performance in any field of application.

The detectors communicate with the controller boards **BR-XS-CTRL32** and **BR-XS-CTRL64**, the most powerful of them can manage **up to 64 sensors on a single communication bus**. These boards enable you to **configure and monitor** even the most complex systems: from a local or a remote PC you can calibrate and configure the sensors, display their status and monitor their operative parameters.

XS-PU interface board enables you to integrate into XENSITY system both **SERIE A03 PRO**, seismic sensors, including the model specific for **glass surfaces**, and **third-party devices** equipped with C/NC outputs.

DETECTOR DSF FOR WINDOWS AND DOORS WITH MAGNETIC CONTACT

PART NUMBER

SN-XS-FDRxM



Dual-tech microprocessor detector for the Point ID protection of windows and doors against burglary, opening, breaking through and drilling. It can be installed in any inclination and orientation and it is available with either thicker or thinner fixing base: the thicker base is compatible with the connection cable wrapped with flexible metal conduit.

The sensor employs tamper devices to signal the sensor removal, case opening and magnetic masking attempts. It also manages two triple-balanced lines for the connection of third-party passive devices with C/NC contact.

COMPLIANCE

IF CONNECTED TO BR-XS-CTRL32 or BR-XS-CTRL64:

- **Directive 2014/30/EU (EMC)**
 - EN 50130-4:2011+A1:2014
 - EN 61000-6-3:2007+A1:2011
- **Directive 2011/65/EU (RoHS)**
 - EN 50581:2012
- **Standard EN 50131-1:2006+A1:2009+A2:2017**
 - EN 50131-2-6:2008



TECHNICAL FEATURES

- **Security grade:** Grade 3 certified (EN 50131-2-6:2008)
- **Environmental class:** Class II certified
- **Dimensions:**
 - SN-XS-FDRLM: 85 x 27 x 20 mm (W x H x D)
 - SN-XS-FDRHM: 85 x 27 x 20 mm (W x H x D)
- **Dimensions magnet:** 83 x 15 x 15 mm (W x H x D)
- **Packaging dimensions:** 110 x 110 x 35 mm (W x H x D)
- **Gross weight:** SN-XS-FDRLM: 112 g - SN-XS-FDRHM: 112 g
- **Net weight:** SN-XS-FDRLM: 35 g - SN-XS-FDRHM: 33 g
- **Operating air gap magnet/sensor:** 6 mm
- **Material:** ABS
- **Colour:** white (SN-XS-FDRLM), grey (SN-XS-FDRHM)
- **Power supply:** powered by XENSITY (12 Vdc)
- **Current:** 4 mA (max)
- **Operating temperature:**
 - -20 °C ÷ +70 °C non certified
 - -10 °C ÷ +40 °C (75% H.R.) certified
- **Relative humidity:** <95% non condensing
- **IP rating:** IP40
- **Functions and devices:**
 - case anti-opening tamper
 - detector anti-removal tamper
 - detector thermal tamper detection
 - magnetic anti-masking tamper
 - self-test function
- **Inputs:**
 - XENSITY bus
 - 2 triple-balanced lines
- **Management capability:** max 2 third-party devices equipped with C/NC contact
- **Configuration via Controller board**
- **Coverage area*:** up to 4 m² (2 x 2 m)

(* Can vary depending on the dimensions, the material and the type of structure.



SN-XS-FDRxM sensors must be connected to BR-XS-CTRL32 or BR-XS-CTRL64 controller board by means of XENSITY bus. The connection is made using CB-XS cable. The maximum distance between the controller board and the last sensor of a bus is 500 metres.



The sensors provided with thinner base are available in white colour only, whilst the ones with thicker base are available in grey colour only. However, thinner bases in grey colour and thicker bases in white colour can be purchased as spare parts (see page 47).

PART NUMBER	DESCRIPTION	COLOUR
SN-XS-FDRLM	DSF detector for doors and windows - equipped with thinner base and magnetic contact	WHITE
SN-XS-FDRHM	DSF detector for doors and windows - equipped with thicker base and magnetic contact	GREY

DETECTOR DSF FOR WINDOWS AND DOORS

PART NUMBER

SN-XS-FDRx



Dual-tech Point ID detector for the protection of doors and windows against burglary, breaking through and drilling. It can be installed in any inclination and orientation and it is available with either thinner or thicker fixing base: the thicker base is compatible with the connection cable wrapped with flexible metal conduit. The sensor employs tamper devices to signal removal, case opening and magnetic masking attempts. In addition, it manages two triple balanced lines for the integration of third-party passive devices equipped with C/NC contact.

COMPLIANCE

IF CONNECTED TO BR-XS-CTRL32 or BR-XS-CTRL64:

- **Directive 2014/30/EU (EMC)**
 - EN 50130-4:2011+A1:2014
 - EN 61000-6-3:2007+A1:2011
- **Directive 2011/65/EU (RoHS)**
 - EN 50581:2012

TECHNICAL FEATURES

- **Dimensions:**
 - **SN-XS-FDRL:** 85 x 27 x 20 mm (W x H x D)
 - **SN-XS-FDRH:** 85 x 27 x 20 mm (W x H x D)
- **Packaging dimensions:** 110 x 110 x 35 mm (W x H x D)
- **Gross weight:** SN-XS-FDRL: 92 g - SN-XS-FDRH: 92 g
- **Net weight:** SN-XS-FDRL: 28 g - SN-XS-FDRH: 26 g
- **Material:** ABS
- **Colour:** white (SN-XS-FDRL), grey (SN-XS-FDRH)
- **Power supply:** via XENSITY bus (12 Vdc)
- **Current:** 4 mA (max)
- **Operating temperature:**
 - -20 °C ÷ +70 °C
 - -10 °C ÷ +40 °C (75% H.R.) certified
- **Relative humidity:** <95% non condensing
- **IP rating:** IP40
- **Functions and devices:**
 - case anti-opening tamper
 - detector anti-removal tamper
 - detector thermal tamper detection
 - self-test function
- **Inputs:**
 - XENSITY bus
 - 2 triple-balanced lines
- **Management capability:** max 2 third-party devices equipped with C/NC contact
- **Configuration via Controller board**
- **Average coverage area*:** up to 4 m² (2 x 2 m)

(*) Can vary depending on the dimensions, the material and the type of structure.



SN-XS-FDRx sensors must be connected to BR-XS-CTRL32 or BR-XS-CTRL64 controller board by means of XENSITY bus. The connection is made using CB-XS cable. The maximum distance between the controller board and the last sensor of a bus is 500 metres.



The configuration and calibration of the detector can be performed only after connecting the DG-DEA-WF2 dongle and installing the specific service app on an Android or IOS mobile device.

PART NUMBER	DESCRIPTION	COLOUR
SN-XS-FDRL	DSF detector for doors and windows with thinner base	WHITE
SN-XS-FDRH	DSF detector for doors and windows with thicker base	GREY

XENSITY



Module for the protection of metal burglar bars against cut, shock and breaking through. It is composed of SN-XS-GR piezoceramic sensor equipped with cable protected by flexible metal tube and of BR-XS-GR addressable peripheral analysis board. The latter manages two triple balancing lines for the connection to third-party devices equipped with C/NC contact.

COMPLIANCE

IF CONNECTED TO BR-XS-CTRL32 or BR-XS-CTRL64:

- **Directive 2014/30/EU (EMC)**
 - EN 50130-4:2011+A1:2014
 - EN 61000-6-3:2007+A1:2011
- **Directive 2011/65/EU (RoHS)**
 - EN 50581:2012

TECHNICAL FEATURES

- **Sensor dimensions:** 33 x 75 x 17 mm (W x H x D)
- **Sensor cable length:** 1.5 m
- **Analysis board dimensions:**
 - (without base): 55 x 50 x 17 mm (W x H x D)
 - (with base): 61 x 56 x 32 mm (W x H x D)
- **Packaging dimensions:** 160 x 160 x 55 mm (W x H x D)
- **Gross weight:** 266 g
- **Sensor material:** glass fibre reinforced nylon
- **Analysis board material:** ABS
- **Colour:** grey
- **Power supply:** powered by XENSITY (12 Vdc)
- **Current:** 6 mA (max)
- **Operating temperature:** -25 °C ÷ +70 °C
- **Relative humidity:** <95% non condensing
- **Sensor IP rating:** IP64
- **Analysis board IP rating:** IP40
- **Functions and devices:**
 - anti-opening tamper (analysis board case)
 - thermal tamper detection (module)
 - thermal expansion digital filter
 - self-test function (module)
- **Inputs:**
 - XENSITY bus
 - SN-XS-GR sensor-line
 - 2 triple-balanced lines for third-party passive devices with C/NC contact
- **Configuration via Controller board**
- **Average coverage area*:** 4 m² (2 x 2 m)^(*)

(*) Can vary depending on the dimensions, the material and the type of structure.



Even though SN-XS-GR sensor has been designed to operate outdoors, BR-XS-GR board must be installed indoors, protected against atmospheric agents.



BR-XS-GR must be connected to XENSITY Bus using CB-XS cable. The distance between BR-XS-GR and SN-XS-GR must be no more than 3 metres.

PART NUMBER	DESCRIPTION	COLOUR
MD-XS-GR	Detection module for the protection of metal burglar bars	GREY

DETECTOR DSF FOR WALLS AND ARMoured STRUCTURES

PART NUMBER

SN-XS-FWL



Dual-tech microprocessor detector for a Point ID protection of walls and armoured structures against breaking, breaking through and drilling attempts.

It detects thermal and magnetic tamper, sensor removal and case opening attempts. It also manages two triple-balanced lines for the integration of third-party passive devices equipped with C/NC contact.

COMPLIANCE

IF CONNECTED TO BR-XS-CTRL32 OR BR-XS-CTRL64:

- **Directive 2014/30/EU (EMC)**
 - EN 50130-4:2011+A1:2014
 - EN 61000-6-3:2007+A1:2011
- **Directive 2011/65/EU (RoHS)**
 - EN 50581:2012
- **Standard EN 50131-1:2006+A1:2009+A2:2017**
 - EN 50131-2-8:2016



TECHNICAL FEATURES

- **Security grade:** Grade 3 certified (EN 50131-2-8:2016)
- **Environmental class:** Class II certified
- **Dimensions:** 89 x 89 x 20 mm (W x H x D)
- **Packaging dimensions:** 90 x 130 x 35 mm (W x H x D)
- **Gross weight:** 132 g
- **Net weight:** 78 g
- **Material:** ABS
- **Colour:** white
- **Power supply:** via XENSITY bus (12 Vdc)
- **Current:** 5 mA (max)
- **Operating temperature:**
 - -20 °C ÷ +70 °C non certified
 - -10 °C ÷ +40 °C (75% H.R.) certified
- **Relative humidity:** <95% non condensing
- **IP rating:** IP40
- **Functions and devices:**
 - case anti-opening tamper
 - sensor anti-removal tamper
 - thermal tamper detection
 - self-test function
- **Inputs:**
 - XENSITY bus
 - 2 triple-balanced lines for third-party devices with C/NC contact
- **Configuration via Controller board**
- **Coverage area*:** up to 46 m² (custom mode)

(*) Can vary depending on the dimensions, the material and the type of structure.



SN-XS-FWL sensors must be connected to BR-XS-CTRL32 or BR-XS-CTRL64 controller board by means of XENSITY bus. The connection is made using CB-XS cable. The maximum distance between the controller board and the last sensor of a bus is 500 metres.

PART NUMBER	DESCRIPTION	COLOUR
SN-XS-FWL	DSF detector for walls and armoured structures	WHITE

CONTROLLER BOARD FOR 32 SENSORS

PART NUMBER
BR-XS-CTRL32



Controller board which manages up to **32 XENSIVITY sensors/peripheral devices**, among which a maximum of 24 BR-XS-SMCAPI boards. It has the function to supply power, check the operating status and receive signals from each device connected to the bus, store them in an internal memory making this information available through relay contacts, DEA NET proprietary network or IP network. The service software enables you to configure and monitor, locally or from remote station, all the detectors and the relay expansion boards (if any) connected to the controller board.

COMPLIANCE

IF CONNECTED TO XENSIVITY SENSOR/PERIPHERAL DEVICES:

- **Directive 2014/30/EU (EMC)**
 - EN 50130-4:2011+A1:2014
 - EN 61000-6-3:2007+A1:2011
- **Directive 2011/65/EU (RoHS)**
 - EN 50581:2012
- **Standard EN 50131-1:2006+A1:2009+A2:2017**
 - EN 50131-2-6:2008
 - EN 50131-2-8:2016



TECHNICAL FEATURES

- **Security grade:** Grade 3 certified
(EN 50131-2-6:2008 if connected to SN-XS-FDRM)
(EN 50131-2-8:2016 if connected to SN-XS-FWL)
- **Dimensions:** 178 x 116 x 30 mm (W x H x D)
- **Packaging dimensions:** 235 x 170 x 70 mm (W x H x D)
- **Gross weight:** 604 g
- **Net weight:** 302 g
- **Power supply:** 12 Vdc (+/-25%)
- **Current:** 0.5 A (max)
- **Operating temperature:**
 - -10 ÷ +40 °C
 - -25 °C ÷ +70 °C (non certified)
- **Relative humidity:** <95% non condensing
- **Management capability:** up to 32 sensors/peripheral devices
- **Inputs:** 4 digital opto-isolated
- **NC relay outputs (positive security):**
 - general intrusion alarm
 - general tamper
- low supply voltage/service activities/electronic board fault
- sensor fail/self-test failed
- bus link loss
- 8 programmable
- **Auxiliary C/NC relay outputs:** up to 64 on 4 BR-XS-RE16L
- **OC outputs :** 2 programmable
- **Communication port:**
 - Ethernet (RJ45)
 - USB (PC link)
 - DEA NET bus
 - connector for flat cable (BR-XS-RE16L)
- **Calibrations and configurations using service software**
- **CPU:** 32 bit
- **Digital memory:** more than 20.000 events
- **Service software licence included**



BR-XS-CTRL32 must be installed inside a case protected against opening.



BR-XS-PU and BR-XS-GR boards, when connected to BR-XS-CTRL32, are managed as sensors.



BR-XS-CTRL32 can manage up to 4 BR-XS-RE16L expansion boards through dedicated communication interface.

PART NUMBER

BR-XS-CTRL32

DESCRIPTION

Controller board for the management of 32 sensors/peripheral devices

CONTROLLER BOARD FOR 64 SENSORS

PART NUMBER
BR-XS-CTRL64



Controller board which manages up to **64 XENSITY sensors/peripheral devices**, among which a maximum of 24 BR-XS-SMCAPI boards. It has the function to supply power, check the operating status and receive signals from each device connected to the bus, store them in an internal memory making this information available through relay contacts, DEA NET proprietary network or IP network. The service software enables you to configure and monitor, locally or from remote station, all the detectors and the relay expansion boards (if any) connected to the controller board.

COMPLIANCE

IF CONNECTED TO XENSITY SENSOR/PERIPHERAL DEVICES:

- **Directive 2014/30/EU (EMC)**
 - EN 50130-4:2011+A1:2014
 - EN 61000-6-3:2007+A1:2011
- **Directive 2011/65/EU (RoHS)**
 - EN 50581:2012
- **Standard EN 50131-1:2006+A1:2009**
 - EN 50131-2-6:2008
 - EN 50131-2-8:2016



TECHNICAL FEATURES

- **Security grade:** Grade 3 certified
(EN 50131-2-6:2008 if connected to SN-XS-FDRM)
(EN 50131-2-8:2016 if connected to SN-XS-FWL)
- **Dimensions:** 178 x 116 x 30 mm (W x H x D)
- **Packaging dimensions:** 235 x 170 x 70 mm (W x H x D)
- **Gross weight:** 604 g
- **Net weight:** 302 g
- **Power supply:** 12 Vdc (+/-25%)
- **Current:** 0.5 A (max)
- **Operating temperature:**
 - -10 ÷ +40 °C
 - -25 °C ÷ +70 °C (non certified)
- **Relative humidity:** <95% non condensing
- **Management capability:** up to 64 sensors/peripheral devices
- **Inputs:** 4 digital opto-isolated
- **NC relay outputs (positive security):**
 - general intrusion alarm
 - general tamper
 - low supply voltage/service activities/electronic board fault
 - sensor fail/self-test failed
 - bus link loss
 - 8 programmable
- **Auxiliary C/NC relay outputs:** up to 96 on 6 BR-XS-RE16L
- **OC outputs :** 2 programmable
- **Communication port:**
 - Ethernet (RJ45)
 - USB (PC link)
 - DEA NET bus
 - connector for flat cable (BR-XS-RE16L)
- **Calibrations and configurations using service software**
- **CPU:** 64 bit
- **Digital memory:** more than 20.000 events
- **Service software licence included**



BR-XS-CTRL64 must be installed inside a case protected against opening.



BR-XS-PU and BR-XS-GR boards, when connected to BR-XS-CTRL64, are managed as sensors.



BR-XS-CTRL64 can manage up to 6 BR-XS-RE16L expansion boards through dedicated communication interface.

PART NUMBER

BR-XS-CTRL64

DESCRIPTION

Controller board for the management of 64 sensors/peripheral devices



Peripheral analysis board for the connection of SN-A03P-GL sensors or third-party devices to XENSITY Bus. This board is equipped with a microprocessor analysis unit which processes the analog signals coming from the sensor and sends the alarm signals to the controller board. When coupled with SN-A03P-GL sensor, it replaces the related processing boards. BR-XS-PU can discriminate burglary events (low attacks), breaking through events (single heavy attacks), and drilling events (continuous vibrations); it is also equipped with opening tamper and thermal tamper electronic device.

COMPLIANCE

IF CONNECTED TO BR-XS-CTRL32 OR BR-XS-CTRL64:

- **Directive 2014/30/EU (EMC)**
 - EN 50130-4:2011+A1:2014
 - EN 61000-6-3:2007+A1:2011
- **Directive 2011/65/EU (RoHS)**
 - EN 50581:2012

TECHNICAL FEATURES

- **Dimensions:**
 - (without base): 55 x 50 x 17 mm (W x H x D)
 - (with base): 61 x 56 x 32 mm (W x H x D)
- **Packaging dimensions:** 110 x 110 x 35 mm (W x H x D)
- **Gross weight:** 77 g
- **Net weight:** 43 g
- **Material:** ABS
- **Colour:** white
- **Power supply:** 12 Vdc powered by XENSITY
- **Current:** 6 mA (max)
- **Operating temperature:** -20 °C ÷ +70 °C
- **Relative humidity:** <95% non condensing
- **IP rating:** IP40
- **Functions and devices:**
 - case anti-opening tamper
 - thermal tamper detection
 - self-test analysis unit
- **Inputs:**
 - XENSITY bus
 - SERIE A03 PRO (excluding SN-A03P-DRM)
 - 2 triple-balanced lines
- **Management capability:**
 - max 1 SN-A03P-GL sensor
 - max 2 third-party passive devices with C/NC contact
- **Configuration via Controller board**



BR-XS-PU must be connected to XENSITY Bus using CB-XS cable.



The distance between BR-XS-PU and sensor must be no more than 3 metres.

PART NUMBER	DESCRIPTION	COLOUR
BR-XS-PU	Peripheral analysis board for SERIE A03 PRO sensors	WHITE

INTERFACE PERIPHERAL BOARD FOR SISMA CA/CA PF

PART NUMBER

BR-XS-SMCAPU

NEW



Interface board for one SISMA CA/CA PF sensor-module which amplifies the signals coming from the sensor-module and transmit them to BR-XS-CTRL32/64 board by means of XENSITY bus.

COMPLIANCE

IF CONNECTED TO BR-XS-CTRL32 OR BR-XS-CTRL64:

- **Directive 2014/30/EU (EMC)**
 - EN 50130-4:2011+A1:2014
 - EN 61000-6-3:2021
- **Directive 2011/65/EU (RoHS)**
 - EN 50581:2012
- **CEI 79-2 (2nd edition)**



TECHNICAL FEATURES

- **Dimensions:** 83 x 80 x 40 mm (W x H x D)
- **Packaging dimensions:** 85 x 110 x 60 mm (W x H x D)
- **Gross weight:** 115 g
- **Net weight:** 62 g
- **Power supply:** by means of XENSITY bus (12 Vdc)
- **Current:** 5 mA (max)
- **Operating temperature:** -25 °C ÷ +80 °C
- **Relative humidity:** <95% non condensing
- **Management capability:**
 - 1 SISMA CA/CA PF sensor-module
- **Inputs:**
 - 1 SISMA CA/CA PF sensor-module
 - XENSITY bus
- **Configuration and programming by means of the control board**



Each peripheral device manages one SISMA CA/CA PF sensor-module.

PART NUMBER

BR-XS-SMCAPU

DESCRIPTION

Interface peripheral board for SISMA CA/CA PF

INTERFACE PERIPHERAL BOARD FOR THIRD PARTY DEVICES

PART NUMBER

BR-XS-TPS

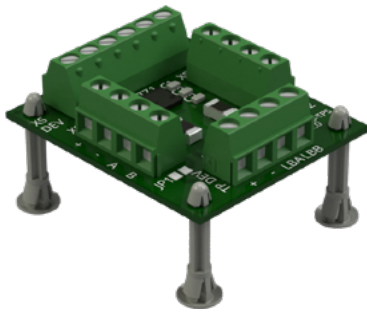

Interface peripheral board for the connection of third party devices to XENSITY bus. This board, which can be exclusively used with BR-XS-CTRL32 controller, powers the device connected to it and sends the signals to XENSITY system. It does not need any local power supply.

COMPLIANCE

IF CONNECTED TO BR-XS-CTRL32 OR BR-XS-CTRL64:

- **Directive 2014/30/EU (EMC)**
 - EN 50130-4:2011+A1:2014
 - EN 61000-6-3:2007+A1:2011
- **Directive 2011/65/EU (RoHS)**
 - EN 50581:2012

TECHNICAL FEATURES

- **Dimensions:** 35 x 13 x 40.5 mm (W x H x D)
- **Gross weight:** 40 g
- **Net weight:** 35 g
- **Power supply:** powered by XENSITY (12 Vdc)
- **Operating temperature:** -20 °C ÷ +70 °C
- **Relative humidity:** <95% non condensing
- **Inputs:**
 - XENSITY bus
 - XENSITY sensor
 - third party active device
- **Outputs:** XENSITY bus
- **Management capability:**
 - 1 XENSITY sensor/peripheral device
 - 1 third party active device with C/NC magnetic contact
- **Configuration via Controller board**



BR-XS-TPS can be employed with BR-XS-CTRL32 controller board only.



Each BR-XS-TPS can manage a single third party device.



You can connect up to 5 third party devices to a single XENSITY bus.



The current drawn by the third party device connected to BR-XS-TPS must be lower than 35mA (15mA stand-by).

PART NUMBER	DESCRIPTION
BR-XS-TPS	Interface peripheral board for third party devices

16-RELAY EXPANSION BOARD

PART NUMBER
BR-XS-RE16L

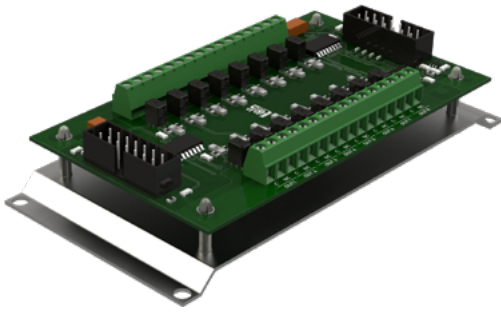

16-relay expansion board to make the alarm signals available through C/NC contacts.
All the relay outputs can be programmed via software from BR-XS-CTRL32 or BR-XS-CTRL64 Controller boards.

COMPLIANCE

IF CONNECTED TO BR-XS-CTRL32 OR BR-XS-CTRL64:

- **Directive 2014/30/EU (EMC)**
 - EN 50130-4:2011+A1:2014
 - EN 61000-6-3:2007+A1:2011
- **Directive 2011/65/EU (RoHS)**
 - EN 50581:2012

TECHNICAL FEATURES

- **Dimensions:** 130 x 64 x 29 mm (W x H x D)
- **Packaging dimensions:** 145 x 70 x 67 mm (W x H x D)
- **Gross weight:** 150 g
- **Net weight:** 70 g
- **Power supply:** provided by controller board
- **Current:** 30 mA (max)
- **Operating temperature:** -25 ÷ +80 °C
- **Relative humidity:** <95% non condensing
- **C/NC relay outputs:** 16-relay outputs programmable from service software
- **Connections:** 14-pin connector for flat cable



BR-XS-RE16L works with BR-XS-CTRL32 and BR-XS-CTRL64 Controller boards only.



The board must be installed inside a case protected against opening.

PART NUMBER

BR-XS-RE16L

DESCRIPTION

16-relay expansion board for BR-XS-CTRL32 and BR-XS-CTRL64



4-wire shielded cable for the connection of XENSITY sensors/peripheral devices to BR-XS-CTRL32 and BR-XS-CTRL64 Controller boards.

COMPLIANCE

- CEI 20-11, CEI-UNEL 36762, CEI 20-22 II, CEI 20-35
- EN 50363, EN 50575:2014+A1:2016
- IEC 60332-3-22, IEC 60332-1-2
- Directive 2014/35/EU, Directive RoHS 2011/65/EU
- 2002/95/EC

TECHNICAL FEATURES

- **Gross weight:**
 - CB-XS-100: 4.5 Kg
 - CB-XS-200: 9 Kg
- **Nominal diameter:** 4.80 +/- 0.2 mm
- **Conductors:** 2 twisted pairs, bare copper
- **Insulation:** special flame retardant PVC compound (quality R2-TI2 - CEI 20-11, EN 50363)
- **Cross sectional area:**
 - 0.5 mm² (power supply - red/black)
 - 0.22 mm² (communication - white/blu)
- **Lay up:** in round shape
- **Shield:** Polyester-Aluminium foil tape (coverage >100%), with bare copper drain wire cross (sect. 0.15 mm²)
- **Jacket:** special flame retardant PVC compound (quality TM2-RZ - CEI 20-11, EN 50363)
- **Colour:** white
- **Working voltage:** 50 Vac; 120 Vdc
- **Test voltage:** 500 Vac (1.000 Vdc)
- **Outer jacket test voltage:** 2.000 Vac (CEI-UNEL 36762)
- **Insulation voltage:** 0.6/1kV (outwards)
- **Bending radius:** 15 times outer diameter
- **Operating temperature:** -15 ÷ +80 °C
- **Short circuit temperature:** max 150 °C
- **Use:** suitable for being installed in a grouping of cables with nominal voltage U_o/U 0.6/1kV max
- **Special features:** fire retardant cables CEI 20-22/II, EN 60332-3-22, IEC 60332-3-22 (IEC 60332.3A)
- **Class reaction to fire:** Eca (EN 50575: 2014+A1:2016. In compliance with annex III Regulation UE N. 305/2011)



The length of CB-XS cable connecting a XENSITY sensor to the relevant Controller board cannot be more than 500 metres.

Il connection cable di collegamento è disponibile in matasse da 100 e 200 metri.

PART NUMBER	DESCRIPTION	COLOUR
CB-XS-100	Connection cable - 100 m reel	WHITE
CB-XS-200	Connection cable - 200 m reel	WHITE

FLEXIBLE METAL TUBE FOR CABLE

PART NUMBER
MS-XS



Flexible metal tube for the protection of the connection cable of SN-XS-DR sensors equipped with thicker base. It is made of galvanized steel with single seam, PVC vacuum covered.

TECHNICAL FEATURES

- **Dimensions:** 7 x 10 mm (Ø int. x Ø est.), 1/4"
- **Gross weight:** 2.45 Kg
- **Minimum bending radius:** 25 mm
- **Operating temperature:** -15 ÷ +70 °C
- **Colour:** grey



MS-XS metal tube must be used with SN-XS-FDRH and SN-XS-FDRHM sensors. If you have SN-XS-FDRL or SN-XS-FDRLM models (equipped with thinner base), the thicker base can be purchased as spare part (please see SB-XS-DR).

PART NUMBER	DESCRIPTION	LENGTH	COLOUR
MS-XS-25	Flexible metal tube for CB-XS connection cable	25 m	GREY

FIXING PLATE FOR SN-XS-FWL

PART NUMBER
FP-FWL

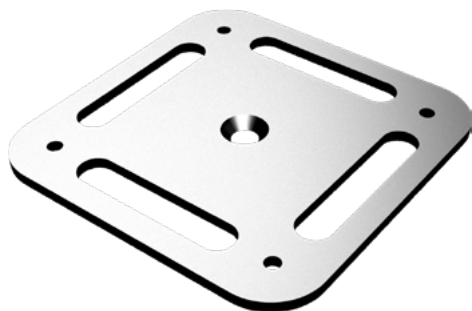

Stainless steel pre-drilled mounting plate to fix SN-XS-FWL sensor to wall or to ceiling. The fixing plate, suitable for being installed both on hollow-core concrete walls and on metal surfaces, simplifies the installation of the sensor and ensures its maximum performance.

TECHNICAL FEATURES

- **Dimensions:** 89 x 3 x 89 mm (W x H x D)
- **Net weight:** 136 g
- **Gross weight:** 166 g
- **Material:** stainless steel
- **Mounting:**
 - 4 holes for sensor fixing
 - 3 holes for wall or ceiling fixing
 - welding slot for metal surfaces

PACKAGE CONTENTS

- 1 plate
- 4 galvanized screws 4 x 8 mm TC+
- 1 galvanized screw 5 x 50 mm TS
- 1 nylon plug SX 8
- 4 M4 steel washers



The plate is equipped with holes for screws, with welding slots and with cable access hole.

PART NUMBER	DESCRIPTION	COLOUR
FP-FWL	Fixing plate for walls and ceilings	GREY

BASES FOR SN-XS-FDRx SENSORS

PART NUMBER
SB-XS-DR



Thinner or thicker base to be used with SN-XS-FDRx sensors.

It is supplied in a pack containing 4 single colour pieces.

COMPLIANCE

- **Dimensions:**
 - SB-XS-FDRL: 85 x 29 x 8 mm (W x H x D)
 - SB-XS-FDRH: 85 x 29 x 13 mm (W x H x D)
- **Package gross weight:**
 - SB-XS-FDRL: 8 g
 - SB-XS-FDRH: 10 g
- **Material:** ABS
- **Colour:** white or grey



The thicker bases allow the use of MD-XS-25 flexible metal conduit to protect the connection cable.

PART NUMBER	DESCRIPTION	PACKAGE	COLOUR
SB-XS-DRLG	Thinner bases for SN-XS-FDRx sensors	4 pieces	GREY
SB-XS-DRLW	Thinner bases for SN-XS-FDRx sensors	4 pieces	WHITE
SB-XS-DRHG	Thicker bases for SN-XS-FDRx sensors	4 pieces	GREY
SB-XS-DRHW	Thicker bases for SN-XS-FDRx sensors	4 pieces	WHITE

SPACERS FOR MAGNETIC CONTACTS

PART NUMBER
MB-XS-DR



Spacer to be used with the magnets of SN-XS-FDRLM and XS-DRHM sensors. It is supplied in a pack containing 4 single colour pieces.

TECHNICAL FEATURES

- **Dimensions:** 83 x 15 x 5 mm (W x H x D)
- **Package gross weight:** 4.3 g
- **Material:** ABS
- **Colour:** white or grey



The thicker bases allow the use of MD-XS-25 flexible metal conduit to protect the connection cable.

PART NUMBER	DESCRIPTION	PACKAGE	COLOUR
MB-XS-DRG	Spacers with magnetic contacts	4 pieces	GREY
MB-XS-DRW	Spacers with magnetic contacts	4 pieces	WHITE

SPARE PARTS

Spare parts to integrate or replace the components of a XENSITY system

PIEZOCERAMIC DETECTOR FOR MD-XS-GR

PART NUMBER

SN-XS-GR



Piezoceramic passive sensor which protects metal burglar bars against shock, cut and breakthrough. Designed for outdoor use, the sensor is protected by a reinforced polyamide housing and the connection cable is wrapped with flexible metal conduit.

SN-XS-GR must be connected to BR-XS-GR analysis board, which processes the signals coming from the sensor and sends the alarm signals (if any) to the Controller board.

COMPLIANCE

IF CONNECTED TO BR-XS-GR:

- **Directive 2014/30/EU (EMC)**
 - EN 50130-4:2011+A1:2014
 - EN 61000-6-3:2007+A1:2011
- **Directive 2011/65/EU (RoHS)**
 - EN 50581:2012

TECHNICAL FEATURES

- **Dimensions:** 33 x 75 x 17 mm (W x H x D)
- **Packaging dimensions:** 170 x 170 x 20 mm (W x H x D)
- **Gross weight:** 244 g
- **Net weight:** 238 g
- **Material:** glass fibre reinforced nylon
- **Colour:** grey
- **Sensor cable length:** 1.5 m
- **Operating temperature:** -25 ÷ +70 °C
- **Relative humidity:** <95% non condensing
- **IP rating:** IP54
- **Average coverage area*:** up to 4 m² (2 x 2 m)

(*) Can vary depending on the dimensions, the material and the type of structure.



SN-XS-GR must be connected to BR-XS-GR analysis board.



The distance between BR-XS-GR and SN-XS-GR must be no more than 3 metres.

PART NUMBER	DESCRIPTION	COLOUR
SN-XS-GR	Piezoceramic detector for burglar bars	GREY

PERIPHERAL ANALYSIS BOARD FOR MD-XS-GR

PART NUMBER

BR-XS-GR



Microprocessor analysis board for SN-XS-GR sensors. It processes the analog signals coming from SN-XS-GR sensor and sends the alarm signals (if any) to the Controller board through XENSITY Bus. BR-XS-GR can discriminate between cut (continuous vibrations), shock (weak impacts) and breakthrough (strong impacts); it also allows filtering nuisance alarms due to thermal expansion of the metal structure.

COMPLIANCE

IF CONNECTED TO BR-XS-CTRL32 OR BR-XS-CTRL64:

- **Directive 2014/30/EU (EMC)**
 - EN 50130-4:2011+A1:2014
 - EN 61000-6-3:2007+A1:2011
- **Directive 2011/65/EU (RoHS)**
 - EN 50581:2012

TECHNICAL FEATURES

- **Dimensions:**
 - (without base): 55 x 50 x 17 mm (W x H x D)
 - (with base): 61 x 56 x 32 mm (W x H x D)
- **Packaging dimensions:** 110 x 110 x 35 mm (W x H x D)
- **Gross weight:** 77 g
- **Net weight:** 43 g
- **Material:** ABS
- **Colour:** grey
- **Power supply:** powered by XENSITY (12 Vdc)
- **Current:** 6 mA (max)
- **Operating temperature:** -25 ÷ +70 °C
- **Relative humidity:** <95% non condensing
- **IP rating:** IP40
- **Functions and devices:**
 - case anti-opening tamper
 - analysis unit thermal tamper detection
 - sensor thermal tamper detection
 - thermal expansion digital filter
 - analysis unit and sensor self-test function
- **Inputs:**
 - XENSITY bus
 - 1 SN-XS-GR sensor
 - 2 triple-balanced lines (third party device with C/NC magnetic contact)
- **Management capability:** max 2 third-party sensors with C/NC relay contact C/NC
- **Configuration via Controller board**



BR-XS-GR must be connected to BR-XS-CTRL32 or BR-XS-CTRL64 Controller boards using XENSITY Bus that provides both data and power connections in one cable.



The distance between BR-XS-GR and SN-XS-GR must be no more than 3 metres.

PART NUMBER	DESCRIPTION	COLOUR
BR-XS-GR	Peripheral analysis board for XS-GR detectors	GREY

APPLICATION EXAMPLES

TYPICAL CONFIGURATION OF THE SYSTEM

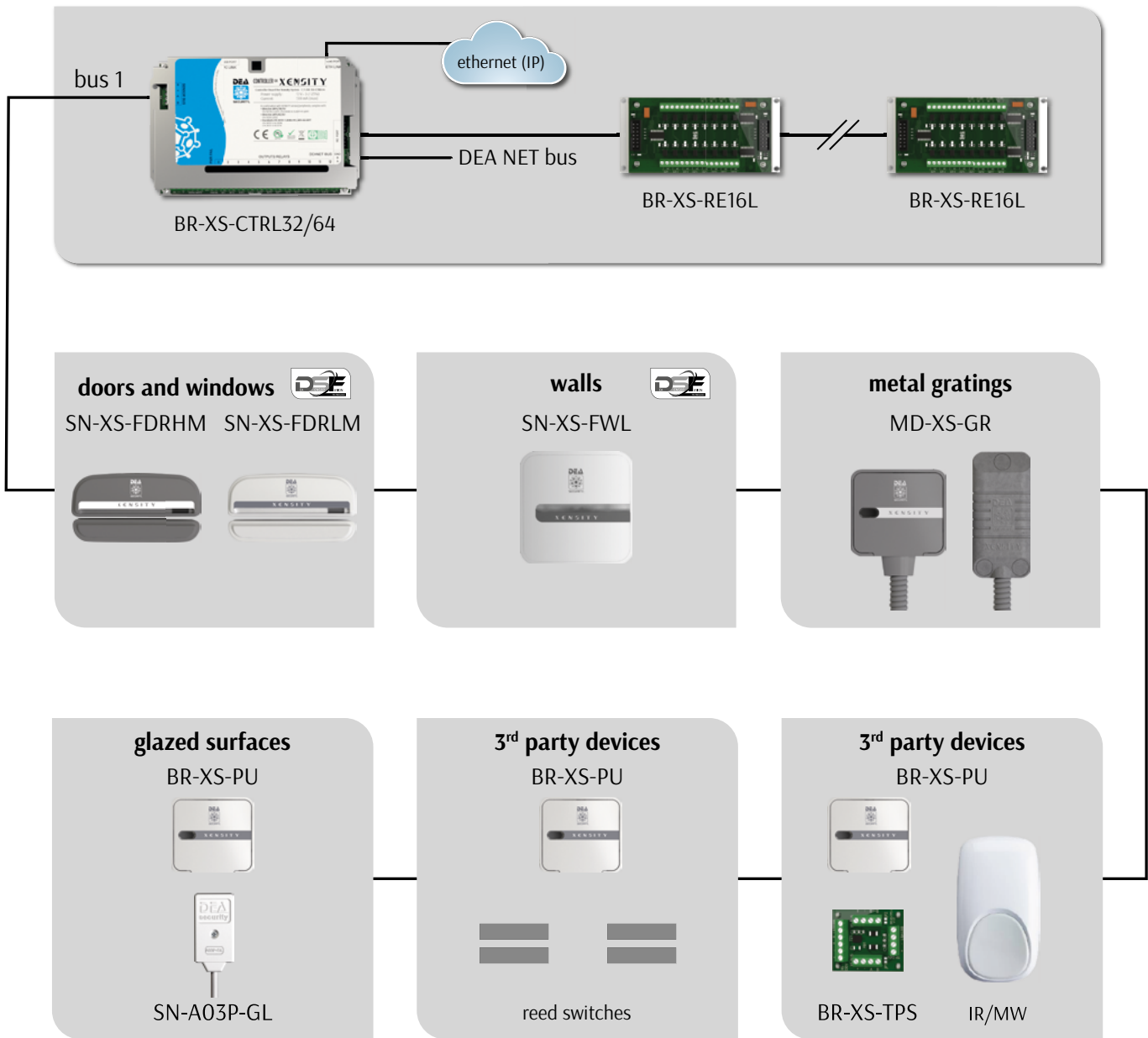

EXAMPLE OF PROTECTION OF A BANK

Let's suppose we are protecting a one-storey bank building. Below the list of structures to protect and the related intrusion sensors.

DESCRIPTION OF THE BUILDING	
24 m outer wall	15 m ² vault ceiling
12 m external glazing	15 m ² vault floor
2 m external window bar	5 m vault internal wall
1 emergency exit door	1 vault door
1 front door	

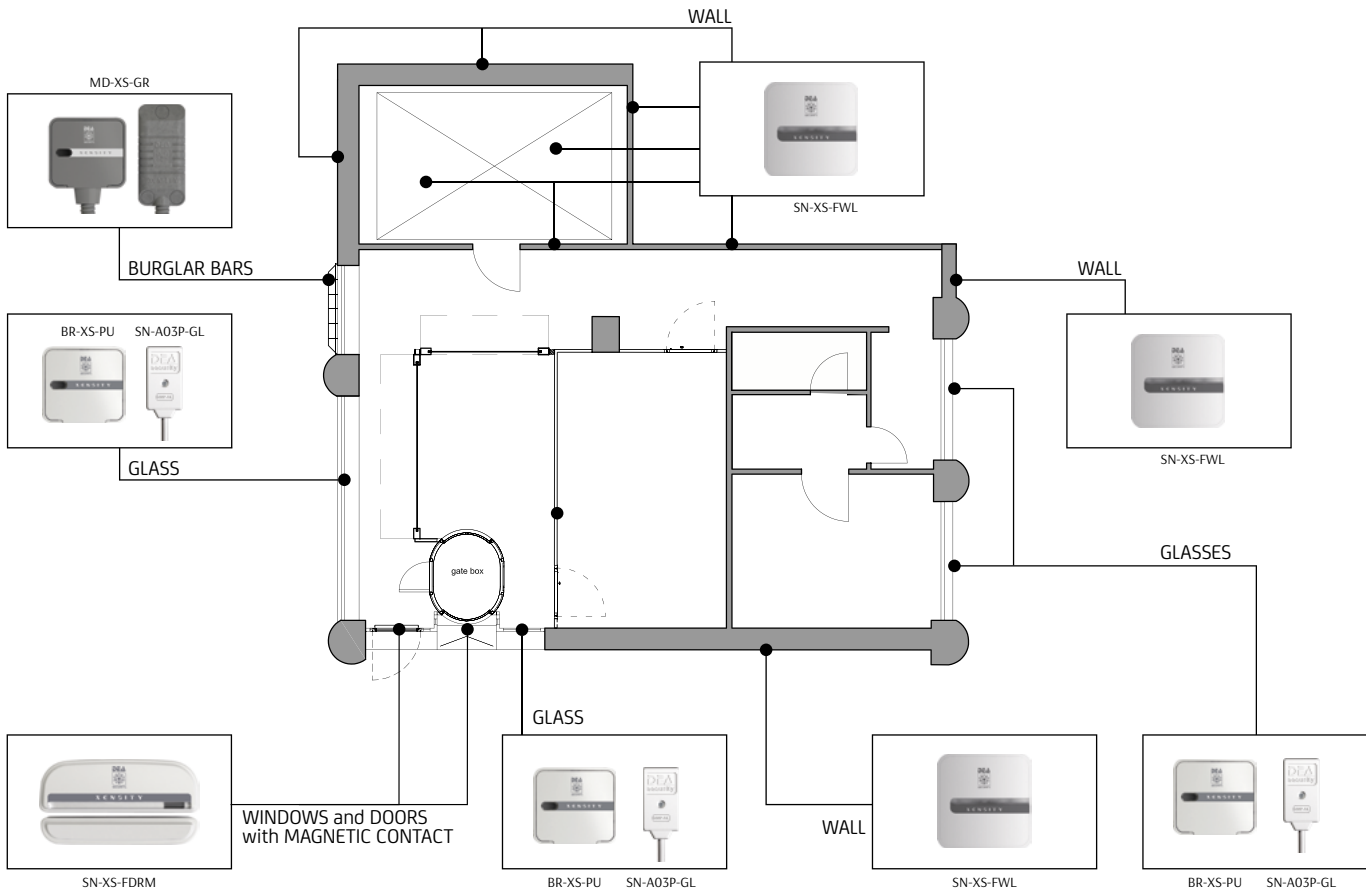

List of parts to make a system as per the above example:

Q.TY	PART NUMBER	DESCRIPTION
2	SN-XS-FDRLM	DSF detectors for doors and windows with thinner base and magnetic contact
1	SN-XS-FDRHM	DSF detectors for doors and windows with thicker base and magnetic contact
1	MD-XS-GR	detection module for the protection of burglar bars
8	SN-A03P-GL	SERIE A03 PRO detectors for glazed surfaces
8	BR-XS-PU	analysis peripheral boards for SERIE A03 PRO detectors
14	SN-XS-FWL	DSF detectors for walls, ceilings and floors
1	BR-XS-CTRL32	controller electronic board to manage up to 32 detectors
2	BR-XS-RE16L	16-relay expansion boards for BR-XS-CTRL32
1	CB-XS-200	connection cable - 200 m hank

OUTDOOR SYSTEMS

FUSION P2P

FENCE-MOUNTED DUAL-TECH SYSTEM

FUSION P2P is the new generation of DEA fence-mounted intrusion detection systems. It is the first outdoor perimeter system to employ **DSF** (DEA Sensor Fusion), dual tech detection technology, thanks to which it redefines the current industry standard as far as performance and versatility are concerned.

The system can be mounted both on **flexible metal fences** (rolled mesh fence or welded panels) and **rigid metal panels**. It can be also installed on **the most common types of wall**.

FUSION P2P senses and analyses the vibrations and the movements of a fence while an intrusion attempt for **cutting**, **breakthrough** or **climbing** is occurring, discriminating all of those noises which could trigger improper alarms.

The system is composed of prewired sensor-strings (also supplied equipped with armoured cable), preassembled electronic control units, junctions and terminations. The sensor-strings are available with different spacing between the sensors: 5 metres (strings with 5 or 15 sensors) and 3 metres (strings with 5, 15 or 25 sensors). The control unit manages up to 300 detectors on 2 communication buses for 1.500 metres of perimeter if the spacing between the sensors is 5 metres and 900 metres of perimeter if the spacing is 3 metres.



FUSION P2P system is designed designed in accordance with **Security grade 4 (high risk)** of Directive EN 50131-1.



Prewired connectorized sensor-strings with either 3-metre or 5-metre spacing between the sensors. The versions with 3-metre spacing are available in strings composed of 5, 15 and 25 detectors, the ones with 5-metre spacing are available in strings with 5 and 15 detectors.

TECHNICAL FEATURES

Please see SN-FSP2P sensor on page 76 and CB-FSP2P cable on page 58.



The first prewired sensor-string of a bus must be connected to the CU-FSP2P control unit or to the BR-FSP2PLT-CTRL control board "Lite" by means of CBINL-FSP2P or CBINL-FSP2P-A connectorized cable. If the distance between the beginning of the string and the control unit/control board is more than 5 metres, a suitable length of CB-FSP2P or CB-FSP2P-A cable shall be joined to CBINL-FSP2P or CBINL-FSP2P-A cable by means of a JBX-P2P junction case.



One communication bus supports up to 150 sensors using the control unit and up to 100 sensors using BR-FSP2PLT-CTRL control board. Please note that while the control unit manages two buses, the BR-FSP2PLT-CTRL control board manages a single bus. On a single bus can be connected any combination of sensor-strings with 25, 15 and 5 sensors, with or without armoured cable, up to the maximum capacity of the bus.



If needed, it is possible to combine – even on the same communication bus – sensor-strings and cables with or without armour.



DEA Security supplies prewired sensor-strings up to 75 metres long (25 sensors with 3-metre spacing or 15 sensors with 5-metre spacing). If the sensors are installed at less than 3 metres from one another, the distance covered by the prewired string decreases accordingly.



The prewired sensor-strings can be easily joined by using JDVP-FSP2P device which, equipped with easy-plug connectors, needs neither welding nor sealing with resin. The termination of a prewired sensor-string is instead executed with TDV-P2P connectorized device. If for any reason the sensor-string has been cut, the junction and/or termination must be executed by using JBX-P2P and TBX-P2P cases.



The sensor-strings are to be fixed to the fence by means of FPA-150 tie-wraps.

FUSION P2P sensor-string is available in the following versions:

PART NUMBER	DESCRIPTION	SENSOR SPACING	NO. OF SENSORS EACH STRING	COLOUR
LN25-FSP2P-300	Prewired sensor-string	3 m	25	BLACK
LN15-FSP2P-300	Prewired sensor-string	3 m	15	BLACK
LN5-FSP2P-300	Prewired sensor-string	3 m	5	BLACK
LN15-FSP2P-500	Prewired sensor-string	5 m	15	BLACK
LN5-FSP2P-500	Prewired sensor-string	5 m	5	BLACK

SENSOR-STRING WITH ARMoured CABLE

PART NUMBER
LN-FSP2P-A

NEW



Prewired connectorized sensor-strings, equipped with armoured cable, with either 3-metre or 5-metre spacing between the sensors.

The versions with 3-metre spacing are available in strings composed of 5, 15 and 25 detectors, whilst the versions with 5-metre spacing are available in strings with 5 and 15 detectors.

TECHNICAL FEATURES

Please see SN-FSP2P-A sensor on page 77 and CB-FSP2P-A cable on page 59.



The first prewired sensor-string of a bus must be connected to the CU-FSP2P control unit or to the BR-FSP2PLT-CTRL control board "Lite" by means of CBINL-FSP2P or CBINL-FSP2P-A connectorized cable. If the distance between the beginning of the string and the control unit/control board is more than 5 metres, a suitable length of CB-FSP2P or CB-FSP2P-A cable shall be joined to CBINL-FSP2P or CBINL-FSP2P-A cable by means of a JBX-P2P junction case.



One communication bus supports up to 150 sensors using the control unit and up to 100 sensors using BR-FSP2PLT-CTRL control board. Please note that while the control unit manages two buses, the BR-FSP2PLT-CTRL control board manages a single bus. On a single bus can be connected any combination of sensor-strings with 25, 15 and 5 sensors, with or without armoured cable, up to the maximum capacity of the bus.



If needed, it is possible to combine – even on the same communication bus – sensor-strings and cables with or without armour.



DEA Security supplies prewired sensor-strings up to 75 metres long (25 sensors with 3-metre spacing or 15 sensors with 5-metre spacing). If the sensors are installed at less than 3 metres from one another, the distance covered by the prewired string decreases accordingly.



The prewired sensor-strings can be easily joined by using JDVP-FSP2P device which, equipped with easy-plug connectors, needs neither welding nor sealing with resin. The termination of a prewired sensor-string is instead executed with TDV-P2P connectorized device. If for any reason the sensor-string has been cut, the junction and/or termination must be executed by using JBX-P2P and TBX-P2P cases.



The sensor-strings are to be fixed to the fence by means of FPA-150 tie-wraps.

FUSION P2P sensor-string with armoured cable is available in the following versions:

PART NUMBER	DESCRIPTION	SENSOR SPACING	NO. OF SENSORS EACH STRING	COLOUR
LN25-FSP2P-300A	Sensor-string prewired with armoured cable	3 m	25	BLACK
LN15-FSP2P-300A	Sensor-string prewired with armoured cable	3 m	15	BLACK
LN5-FSP2P-300A	Sensor-string prewired with armoured cable	3 m	5	BLACK
LN15-FSP2P-500A	Sensor-string prewired with armoured cable	5 m	15	BLACK
LN5-FSP2P-500A	Sensor-string prewired with armoured cable	5 m	5	BLACK



4-wire shielded cable with anti-rodent armour for the connection of the CU-FSP2P control unit or the BR-FSP2PLT-CTRL control board to a unconnectorized sensor-string or to the CBINL-FSP2P or CBINL-FSP2P-A initial string connectorized cable. It can be also used to execute repairs along the string or to bypass potential discontinuities along the fence.

COMPLIANCE

- CEI 20-29 CL.5, CEI 20-11, CEI 20-35/1-2
- UL 758, UL 1581
- EN 50363, EN 60332-1-2
- IEC 60332-1
- VDE 0282-10
- Directive 2014/35/EU, Directive RoHS 2011/65/EU

TECHNICAL FEATURES

- **External diameter:** 7 mm (±0.15 mm)
- **Conductors:** 2 stranded, flexible, copper pairs of conductors
- **Cross sectional area:**
 - 0.75 mm² (power supply - red/black)
 - 0.22 mm² (communication, pair RS-485 - white/blu)
- **Insulation:** halogen free polyolefin (HDPE high density polyethylene)
- **Shield:** Aluminium/Polyester foil tape with tinned copper drain wire (sect. 0.22 mm²)
- **Lay up:** in pair with fille and polyester protective tape (sect. 0.22 mm²)
- **Total lay up:** in round shape with optional filler and polyester protective tape
- **Jacket:** special flame retardant and oil resistant PVC
- **Colour:** black
- **Working voltage:** 300 V
- **Test voltage:** 1.500 V (cond./cond.; cond./shield)
- **Insulation voltage:** 0.6/1kV
- **Bending radius:** 15 times outer diameter
- **Operating temperature:**
 - -40 ÷ +80 °C (fixed installation)
 - -15 ÷ +80 °C (mobile installation)
- **Nominal cable weight connection cable:** 72.14 Kg/Km



The overall length of the CB-FSP2P cable, of the CVINL-FSP2P cable (if any) and of the sensor-strings connected to the same bus must be 800 metres maximum.



The junction between the CB-FSP2P or CB-FSP2P-A cable and the first connectorized sensor-string of a bus is executed by means of the CBINL-FSP2P or CBINL-FSP2P-A connectorized cable.



If the CU-FSP2P control unit or the BR-FSP2PLT-CTRL control board and the first sensor-string of a bus are 5-metre distant or less, they must be connected by means of CBINL-FSP2P or CBINL-FSP2P-A cable.

FUSION P2P cable is available in 50-metre or 150-metre reels.

PART NUMBER	DESCRIPTION	LENGTH	COLOUR
CB-FSP2P-50	Connection cable	50 m	BLACK
CB-FSP2P-150	Connection cable	150 m	BLACK

NEW



4-wire shielded cable with anti-rodent armour for the connection of the CU-FSP2P control unit or the BR-FSP2PLT-CTRL control board to a unconnectorized sensor-string or to the CBINL-FSP2P or CBINL-FSP2P-A initial string connectorized cable. It can be also used to execute repairs along the string or to bypass potential discontinuities along the fence.

COMPLIANCE

- CEI 20-29 CL.5, CEI 20-11, CEI 20-35/1-2
- UL 758, UL 1581
- EN 50363, EN 60332-1-2
- IEC 60332-1
- VDE 0282-10
- Directive 2014/35/EU, Directive RoHS 2011/65/EU

TECHNICAL FEATURES

- **External diameter:** 9.5 mm (± 0.30 mm)
- **Conductors:** 2 stranded, flexible, copper pairs of conductors
- **Cross sectional area:**
 - 0.75 mm² (power supply - red/black)
 - 0.22 mm² (communication, pair RS-485 - white/blu)
- **Insulation:** halogen free polyolefin (HDPE high density polyethylene)
- **Shield:** Aluminium/Polyester foil tape with tinned copper drain wire (sect. 0.22 mm²)
- **Lay up:** in pair with fille and polyester protective tape (sect. 0.22 mm²)
- **Total lay up:** in round shape with optional filler and polyester protective tape
- **Inner jacket:** special flame retardant and oil resistant PVC (diameter 7 mm \pm 0.30 mm)
- **Armour:** galvanized steel braid – nominal coverage > 75%
- **Jacket:** special flame retardant and oil resistant PVC (diameter 9.5 mm \pm 0.30 mm)
- **Colour:** black
- **Working voltage:** 300 V
- **Test voltage:** 1.500 V (cond./cond.; cond./shield)
- **Insulation voltage:** 0.6/1kV
- **Bending radius:** 15 times outer diameter
- **Operating temperature:**
 - -40 ÷ +80 °C (fixed installation)
 - -15 ÷ +80 °C (mobile installation)



The overall length of the CB-FSP2P-A cable, of the CBINL-FSP2PA cable (if any) and of the sensor-strings connected to the same bus must be 800 metres maximum.



The junction between the CB-FSP2P or CB-FSP2P-A cable and the first connectorized sensor-string of a bus is executed by means of the CBINL-FSP2P or CBINL-FSP2P-A connectorized cable.



If the CU-FSP2P control unit or the BR-FSP2PLT-CTRL control board and the first sensor-string of a bus are 5-metre distant or less, they must be connected by means of CBINL-FSP2P or CBINL-FSP2P-A cable.

FUSION P2P armoured cable is available in 50-metre or 150-metre reels

PART NUMBER	DESCRIPTION	LENGTH	COLOUR
CB-FSP2P-50A	Armoured connection cable	50 m	BLACK
CB-FSP2P-150A	Armoured connection cable	150 m	BLACK

INITIAL STRING CONNECTORIZED CABLE

PART NUMBER
CBINL-FSP2P



5-metre connectorized cable for the connection of the CU-FSP2P control unit or the BR-FSP2PLT-CTRL control board to the first connectorized sensor-string of a bus (LN-FSP2P/LN-FSP2P-A strings or SN-FSP2P/SN-FSP2P-A sensors equipped with CN-FSP2P connectors).

COMPLIANCE

CONNECTION CABLE:

- CEI 20-29 CL.5
- UL 758, UL 1581
- CEI 20-11, CEI 20-35/1-2
- EN 50363, EN 60332-1-2
- IEC 60332-1
- VDE 0282-10
- 2014/35/EU
- EU Directive RoHS 2011/65/EU

CONNECTOR (PLUG):

- CEI 60512-4
- UL 94-V0, UL 1977
- MIL-C-26482, MIL-STD1344
- RoHS

TECHNICAL FEATURES

CONNECTION CABLE: please see CB-FSP2P on page 58.

CONNECTOR (plug):

- **Connector type:** 6-pin female circular plug with bayonet locking
- **Dimensions:** 26.2 x 63.2 mm (Ø max x L)

- **Operating temperature:** -40 ÷ +105 °C
- **Housing material:** thermoplastic resistant to UV rays, mineral oils, hydrocarbons and acids
- **Colour:** black
- **IP rating:** IP68 (if correctly inserted into the relevant socket)



When the CU-FSP2P control unit or the BR-FSP2PLT-CTRL control board is more than 5 metres away from the first sensor-string of a bus, the CBINL-FSP2P or CBINL-FSP2P-A cable must be extended by means of CB-FSP2P or CB-FSP2P-A cable to reach the needed length. The junction between the two cables must be executed with the JBX-P2P case.



The overall length of the CBINL-FSP2P or CBINL-FSP2P-A cable, of the CB-FSP2P or CB-FSP2P-A cable (if any) and of all the sensor-strings connected to the same bus must be 800 metres maximum.

PART NUMBER	DESCRIPTION	COLOUR
CBINL-FSP2P	Initial string connectorized cable	BLACK

INITIAL STRING CONNECTORIZED ARMOURED CABLE

PART NUMBER

CBINL-FSP2PA



NEW



5-metre connectorized cable for the connection of the CU-FSP2P control unit or the BR-FSP2PLT-CTRL control board to the first connectorized sensor-string of a bus (LN-FSP2P/LN-FSP2P-A strings or SN-FSP2P/SN-FSP2P-A sensors equipped with CN-FSP2P connectors).

COMPLIANCE

CONNECTION CABLE:

- CEI 20-29 CL.5
- UL 758, UL 1581
- CEI 20-11, CEI 20-35/1-2
- EN 50363, EN 60332-1-2
- IEC 60332-1
- VDE 0282-10
- 2014/35/EU
- EU Directive RoHS 2011/65/EU

CONNECTOR (PLUG):

- CEI 60512-4
- UL 94-V0, UL 1977
- MIL-C-26482, MIL-STD1344
- RoHS

TECHNICAL FEATURES

CONNECTION CABLE: please see CB-FSP2P-A on page 59.

CONNECTOR (plug):

- **Connector type:** 6-pin female circular plug with bayonet locking
- **Dimensions:** 26.2 x 63.2 mm (Ø max x L)

- **Operating temperature:** -40 ÷ +105 °C
- **Housing material:** thermoplastic resistant to UV rays, mineral oils, hydrocarbons and acids
- **Colour:** black
- **IP rating:** IP68 (if correctly inserted into the relevant socket)



When the CU-FSP2P control unit or the BR-FSP2PLT-CTRL control board is more than 5 metres away from the first sensor-string of a bus, the CBINL-FSP2P or CBINL-FSP2P-A cable must be extended by means of CB-FSP2P or CB-FSP2P-A cable to reach the needed length. The junction between the two cables must be executed with the JBX-P2P case.



The overall length of the CBINL-FSP2P or CBINL-FSP2P-A cable, of the CB-FSP2P or CB-FSP2P-A cable (if any) and of all the sensor-strings connected to the same bus must be 800 metres maximum.

PART NUMBER	DESCRIPTION	COLOUR
CBINL-FSP2PA	Initial string connectorized armoured cable	BLACK

FUSION P2P



Device for the junction of connectorized sensor-strings (LN-FSP2P strings or SN-FSP2P sensors equipped with CN-FSP2P connectors).
It is provided with a UV resistant housing, two easy-plug sockets and a fixing support.

COMPLIANCE

JUNCTION (if connected to LN-FSP2P or LN-FSP2P-A):

- **Directive 2014/30/EU (EMC)**
 - EN 50130-4:2011+A1:2014
 - EN 61000-6-3:2007+A1:2011
- **Directive 2011/65/EU (RoHS)**
 - EN 50581:2012

CONNECTORS:

- CEI 60512-4
- UL94-VO, UL 1977
- MIL-C-26482, MIL-STD1344
- RoHS

TECHNICAL FEATURES

- **Environmental class:** IV (designed in accordance with Directive EN 50130-5)
- **Gross weight:** 123 g
- **Net weight:** 117 g

CASE (junction):

- **Housing dimensions:** 90 x 56 x 43 mm (W x H x D)
- **Fixing plate dimensions:** 90 x 8 mm (Ø x L)
- **Material:** glass fiber reinforced polyamide
- **Colour:** black
- **Operating temperature:** -40 ÷ +80 °C
- **Relative humidity:** <95% non condensing
- **IP rating:** IP54

CONNECTOR (socket):

- **Typology:** 6-contact circular socket
- **Dimensions:** 27 x 33.9 mm (Ømax x L)
- **Material:** thermoplastic resistant to UV rays, mineral oils, hydrocarbons and acids
- **Colour:** black
- **Operating temperature:** -40 ÷ +80 °C
- **Relative humidity:** <95% non condensing
- **IP rating:** IP68 (if correctly inserted into the relevant socket)



To be used for the junction of the sensor-strings equipped with easy-plug connectors.



To join unconnectorized sensor-strings, JBX-P2P case must be used.

PART NUMBER	DESCRIPTION	COLOUR
JDVP-FSP2P	Connectorized junction	BLACK



Device for the termination of connectorized sensor-strings (LN-FSP2P strings or SN-FSP2P sensors equipped with CN-FSP2P connectors).

It is provided with a UV resistant housing, two easy-plug sockets and a fixing support.

COMPLIANCE

TERMINATION (if connected to LN-FSP2P or LN-FSP2P-A):

- **Directive 2014/30/EU (EMC)**
 - › EN 50130-4:2011+A1:2014
 - › EN 61000-6-3:2007+A1:2011
- **Directive 2011/65/EU (RoHS)**
 - › EN 50581:2012

CONNECTORS:

- CEI 60512-4
- UL94-VO, UL 1977
- MIL-C-26482, MIL-STD1344
- RoHS

TECHNICAL FEATURES

- **Environmental class:** IV (designed in accordance with Directive EN 50130-5)
- **Gross weight:** 123 g
- **Net weight:** 117 g

CASE (termination):

- **Housing dimensions:** 90 x 56 x 43 mm (W x H x D)
- **Fixing plate dimensions:** 90 x 8 mm (Ø x L)
- **Material:** glass fiber reinforced polyamide
- **Colour:** black
- **Operating temperature:** -40 ÷ +80 °C
- **Relative humidity:** <95% non condensing
- **IP rating:** IP54

CONNECTOR (socket):

- **Typology:** 6-contact circular socket
- **Dimensions:** 27 x 33.9 mm (Ømax x L)
- **Material:** thermoplastic resistant to UV rays, mineral oils, hydrocarbons and acids
- **Colour:** black
- **Operating temperature:** -40 ÷ +80 °C
- **Relative humidity:** <95% non condensing
- **IP rating:** IP68 (if correctly inserted into the relevant socket)



To be used for the termination of connectorized sensor-strings.



It is provided with a waterproof cap to close one of the two easy-plug sockets unused.



For the termination of unconnectorized sensor-strings, TBX-P2P case must be used.

PART NUMBER	DESCRIPTION	COLOUR
TDV-FSP2P	Connectorized termination	BLACK



UV resistant case for the junction of CB-FSP2P cable with CBINL-FSP2P initial string cable or with other pieces of the same cable (for e.g. to perform a bypass or repairs along the sensor-string).

JBX-P2P is also used if one or more SN-FSP2P unconnectorized sensors are to be joined to another sensor-string. It is supplied with a printed circuit board to simplify the wiring procedures.

COMPLIANCE

IF CONNECTED TO LN-FSP2P OR LN-FSP2P-A:

- **Directive 2014/30/EU (EMC)**
 - EN 50130-4:2011+A1:2014
 - EN 61000-6-3:2007+A1:2011
- **Directive 2011/65/EU (RoHS)**
 - EN 50581:2012

TECHNICAL FEATURES

- **Environmental class:** IV (designed in accordance with Directive EN 50130-5)
- **Dimensions:** 30 x 114 x 30 mm (W x H x D)
- **Gross weight:** 66 g
- **Net weight:** 62 g
- **Material:** glass fiber reinforced polyamide
- **Colour:** black
- **Operating temperature:** -40 ÷ +80 °C
- **Relative humidity:** 0 - 100% (after sealing with RP-100 PUR cast resin)
- **IP rating:** IP68



To be sealed with RP-100 two-component PUR cast resin.



For the junction of connectorized sensor-strings, JDVP-FSP2P junction device must be used.

PART NUMBER	DESCRIPTION	COLOUR
JBX-P2P	Junction unconnectorized sensor-strings	BLACK



UV resistant case for the termination of unconnectorized sensor-strings (LN-FSP2P strings or SN-FSP2P sensors not equipped with easy-plug connectors). It is supplied with a printed circuit board to simplify the wiring procedures.

COMPLIANCE

IF CONNECTED TO LN-FSP2P OR LN-FSP2P-A:

- **Directive 2014/30/EU (EMC)**
 - EN 50130-4:2011+A1:2014
 - EN 61000-6-3:2007+A1:2011
- **Directive 2011/65/EU (RoHS)**
 - EN 50581:2012

TECHNICAL FEATURES

- **Environmental class:** IV (designed in accordance with Directive EN 50130-5)
- **Dimensions:** 30 x 114 x 30 mm (W x H x D)
- **Gross weight:** 66 g
- **Net weight:** 62 g
- **Material:** glass fiber reinforced polyamide
- **Colour:** black
- **Operating temperature:** -40 ÷ +80 °C
- **Relative humidity:** 0 - 100% (after sealing with RP-100 PUR cast resin)
- **IP rating:** IP68



To be sealed with RP-100 two-component PUR cast resin.



For the termination of connectorized sensor-strings, TDV-FSP2P termination device must be used.

PART NUMBER	DESCRIPTION	COLOUR
TBX-P2P	Termination unconnectorized sensor-strings	BLACK



The control unit manages up to 300 detectors on 2 communication buses for maximum 1.500 metres of perimeter if the spacing between the sensors is 5 metres and 900 metres of perimeter if the spacing is 3 metres. Besides enabling the configuration of the detectors by means of a service software, the control unit automatically recognizes and sorts the field detectors and raises the alarm signals.

CU-FSP2P CONTENTS:

- BR-FSP2P-CTRL controller board
- AL-P2P-3024 stabilized power-supply unit
- Two BT-P2P-12V backup batteries
- Tamper switch
- BOX-P2P polyester cabinet

COMPLIANCE

IF CONNECTED TO LN-FSP2P OR LN-FSP2P-A:

- **Directive 2014/30/EU (EMC)**
 - EN 50130-4:2011+A1:2014
 - EN 61000-6-3:2007+A1:2011
- **Directive 2011/65/EU (RoHS)**
 - EN 50581:2012
- **Directive 2014/35/EU (LVD)**
 - EN 62368-1:2014+A11:2017
- **CEI 79-2 (2nd edition)**
- **IEC 60695-2-10, IEC 60695-2-11, IEC 60695-11-5, IEC 622108**

TECHNICAL FEATURES

CONTROL UNIT:

- **Environmental class:** IV (designed in accordance with Directive EN 50130-5)
- **Dimensions:** 300 x 400 x 200 mm (W x H x D)
- **Net weight (batteries excluded):** 7.6 Kg
- **Material:** polyester self-extinguishing housing, provided with ventilation devices
- **Insulation:** double, halogen-free
- **IP rating:** IP66 (IP54 with ventilation devices), IK10
- **Operating temperature:** -30 ÷ +70 °C
- **Termical class:** 105

For the technical data of the single components (controller board, power supply unit and backup batteries) please see the related catalogue entries.



The control unit must be connected to a 115/230 Vac power line.

PART NUMBER	DESCRIPTION
CU-FSP2P	Control Unit

CONTROL UNIT WITH ISOLATORS

PART NUMBER
CU-FSP2P-ISB



NEW



Control Unit version which includes two galvanic isolators for the sensor-strings buses.

CU-FSP2P CONTENTS:

- BR-FSP2P-CTRL controller board
- Two isolators BR-P2P-ISB
- AL-P2P-3024 stabilized power-supply unit
- Two backup batteries BT-P2P-12V
- Tamper switch
- AP1 polyester cabinet

COMPLIANCE

IF CONNECTED TO LN-FSP2P OR LN-FSP2P-A:

- **Directive 2014/30/EU (EMC)**
 - EN 50130-4:2011+A1:2014
 - EN 61000-6-3:2007+A1:2011
- **Directive 2011/65/EU (RoHS)**
 - EN 50581:2012
- **Directive 2014/35/EU (LVD)**
 - EN 62368-1:2014+A11:2017
- **CEI 79-2 (2nd edition)**
- **IEC 60695-2-10, IEC 60695-2-11, IEC 60695-11-5, IEC 62208**

TECHNICAL FEATURES

CONTROL UNIT:

- **Environmental class:** IV (designed in accordance with Directive EN 50130-5)
- **Dimensions:** 400 x 500 x 200 mm (W x H x D)
- **Material:** glass fiber reinforced polyester, self-extinguishing, provided with ventilation devices
- **Insulation:** double, halogen-free
- **IP rating:** IP66 (IP54 with ventilation devices), IK10
- **Operating temperature:** -30 ÷ +70 °C
- **Termical class:** 105

For the technical data of the single components (controller board, isolators, power supply unit and backup batteries) please see the related catalogue entries.



The control unit must be connected to a 115/230 Vac power line.

PART NUMBER	DESCRIPTION
CU-FSP2P-ISB	Control Unit with isolators

FUSION P2P

CONTROL BOARD "LITE"

PART NUMBER
BR-FSP2PLT-CTRL

NEW



Electronic control board which powers and manages up to 100 FUSION P2P sensors on a single communication bus. It performs several functions among which the automatic acquisition and sorting of the sensors, the processing of the alarm signals and the native support to the centralization and remote management of the system over IP networks or DEA NET proprietary network.

COMPLIANCE

IF CONNECTED TO LN-FSP2P OR LN-FSP2P-A:

- **Directive 2014/30/EU (EMC)**
 - EN 50130-4:2011
 - EN 61000-6-3:2007+A1:2011
- **Directive 2011/65/EU (RoHS)**
 - EN 50581:2012
- **CEI 79-2 (2nd edition)**

TECHNICAL FEATURES

- **Dimensions:** 177 x 117 x 40 mm (W x H x D)
- **Packaging dimensions:** 240 x 175 x 65 mm (W x H x D)
- **Gross weight:** 538 g
- **Net weight:** 304 g
- **Power supply:** 12 Vdc (min. 10.8 Vdc - max 15 Vdc)
- **Current:** 395 mA (standby) - 520 mA (max)
- **Operating temperature:** -25 ÷ +70 °C
- **Relative humidity:** <95% non condensing
- **Management capability:** up to 100 sensors
- **Inputs:** 4 optoisolated digital
- **NC relay outputs (positive security):**
 - general intrusion alarm
 - general tamper
 - low supply voltage/service in progress/functioning anomalies of the board
 - sensor fail/self-test failed
 - bus link loss
 - 8 programmable relays outputs
- **OC outputs :** 2 programmable
- **C/NC relay outputs:** up to 96 with 6 BR-XS-RE16L boards
- **Communication port:**
 - USB (PC link)
 - Ethernet (RJ45)
 - DEA NET bus
 - connector for flat cable (BR-XS-RE16L)
- **Calibration, settings and event management via software**
- **CPU:** 32 bit
- **Digital memory:** more than 20.000 events
- **Service software licence included**



The control board must be installed inside a case protected against opening (e.g.: polyester cabinet, junction box etc.) and connected to a 12 Vdc mains.

PART NUMBER	DESCRIPTION
BR-FSP2PLT-CTRL	Control board "Lite"



Peripheral module containing an electronic interface board for the management of a resistive balanced input. It can be connected everywhere along the sensor-string and allows you to integrate into the system signals coming from third-party devices such as magnetic contacts. The printed circuit board is protected by a polyamide housing which provides a very high resistance to UV rays and scratch.

COMPLIANCE

IF CONNECTED TO CU-FSP2P:

- **Directive 2014/30/EU (EMC)**
 - EN 50130-4:2011+A1:2014
 - EN 61000-6-3:2007+A1:2011
- **Directive 2011/65/EU (RoHS)**
 - EN 50581:2012

TECHNICAL FEATURES

- **Environmental class:** IV (designed in accordance with Directive EN 50130-5)
- **Dimensions:** 133 x 52 x 37 mm (W x H x D)
- **Packaging dimensions:** 165 x 85 x 45 mm (W x H x D)
- **Gross weight:** 184 g
- **Net weight:** 144 g
- **Material:** glass fiber reinforced polyamide
- **Colour:** black
- **Operating temperature:** -40 ÷ +80 °C
- **Relative humidity:** 0 - 100% (after sealing with RP-100 PUR cast resin)
- **IP rating:** IP54
- **Inputs:** 1 triple balanced input



FUSION P2P control unit can manage up to 5 SC-P2P-IN1 modules on each bus. Each module binds 1 of the 64 lines and 1 of the 300 sensors managed by the Control Unit.



To be sealed with RP-100 two-component PUR cast resin.

PART NUMBER	DESCRIPTION	COLOUR
SC-P2P-IN1	Peripheral interface module	BLACK

16-RELAY EXPANSION BOARD

PART NUMBER
BR-XS-RE16L

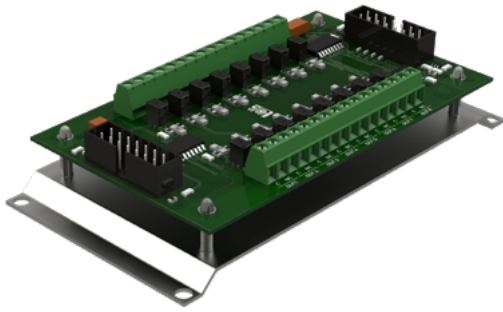

16-relay expansion board to make the alarm signals available through C/NC contacts. All the relay outputs can be programmed via software from BR-FSP2P-CTRL.

COMPLIANCE

IF CONNECTED TO BR-FSP2P-CTRL:

- **Directive 2014/30/EU (EMC)**
 - EN 50130-4:2011+A1:2014
 - EN 61000-6-3:2007+A1:2011
- **Directive 2011/65/EU (RoHS)**
 - EN 50581:2012

TECHNICAL FEATURES

- **Dimensions:** 130 x 64 x 29 mm (W x H x D)
- **Packaging dimensions:** 145 x 70 x 67 mm (W x H x D)
- **Gross weight:** 78 g
- **Power supply:** provided by controller board
- **Current:** 30 mA (max)
- **Operating temperature:** -25 ÷ +80 °C
- **Relative humidity:** <95% non condensing
- **C/NC relay outputs:** 16-relay outputs programmable from service software
- **Connections:** 14-pin connector for flat cable



The board must be installed inside a case protected against opening.



If you need to get the alarm signals remotely, for example near the alarm control panel, you can employ the BR-DN-RE16 expansion boards by connecting them to DN ER bus (DEA NET) present on the controller board.

PART NUMBER	DESCRIPTION
BR-XS-RE16L	16-relay expansion board per BR-FSP2P-CTRL

SPARE PARTS

Spare parts to integrate or replace the components of a FUSION P2P system.



The controller board manages up to 300 FUSION P2P sensors on two communication buses (150 sensors per bus).

It performs several functions among which the automatic acquisition and sorting of the sensors, the processing of the alarm signals and the native support to the centralization and remote management of the system over IP networks.

COMPLIANCE

ASSEMBLED INSIDE IN CU-FSP2P:

- **Directive 2014/30/EU (EMC)**
 - EN 50130-4:2011+A1:2014
 - EN 61000-6-3:2007+A1:2011
- **Directive 2011/65/EU (RoHS)**
 - EN 50581:2012
- **CEI 79-2 (2nd edition)**

TECHNICAL FEATURES

- **Dimensions:** 185 x 160 x 40 mm (W x H x D)
- **Packaging dimensions:** 240 x 175 x 65 mm (W x H x D)
- **Gross weight:** 784 g
- **Net weight:** 466 g
- **Power supply:** 24 Vdc (+/- 25%)
- **Current:** 0.75 A (max)
- **Operating temperature:** -25 ÷ +80 °C
- **Relative humidity:** <95% non condensing
- **Management capability:** up to 150 sensors per bus
- **Digital inputs:** 4 optoisolated, software programmable
- **NC relay outputs (positive security):**
 - low voltage power supply, service in progress, no operating software or functioning anomalies of the board
 - general intrusion alarm
 - general tamper
 - sensor failure
 - bus link loss
 - up to 128 external outputs on optional expansion boards (8 BR-DN-RE16 or BR-XS-RE16L boards)
- **OC/NC outputs:** 3 programmable
- **Communication port:**
 - USB (PC link)
 - Ethernet (RJ45)
- **Calibration, settings and event management via software**
- **CPU:** 32 bit, 168 MHz
- **Digital memory:** more than 20.000 events
- **Service software licence included**

PART NUMBER	DESCRIPTION
BR-FSP2P-CTRL	Controller board

VOLTAGE REGULATOR

PART NUMBER
BR-FSP2PLT-BST



NEW



Electronic voltage regulator (booster) to be coupled with the BR-FSP2PLT-CTRL control board. Its function is to step up voltage from its input (12V) to its output (24V) ensuring the maximum sensor bus stability at full load.

COMPLIANCE

IF CONNECTED TO BR-FSP2PLT-CTRL:

- EN 55032:2012+AC:2013
- EN 55024:2010
- IEC 62368-1:2014

TECHNICAL FEATURES

- **Dimensions:** 40 x 38 x 17 mm (W x H x D)
- **Net weight:** 39 g
- **Power supply:** from BR-FSP2PLT-CTRL
- **Current:** from BR-FSP2PLT-CTRL
- **Input voltage:** 12 Vdc (+/- 25%)
- **Output voltage:** 24 Vdc
- **Operating temperature:** -25 ÷ +70 °C
- **Relative humidity:** <95% non condensing
- **Inputs:** from BR-FSP2PLT-CTRL
- **Output:** to sensors BUS



The control board must be installed inside a case protecting against opening (e.g.: polyester cabinet or junction box).

FUSION P2P

PART NUMBER	DESCRIPTION
BR-FSP2PLT-BST	Voltage regulator

NEW

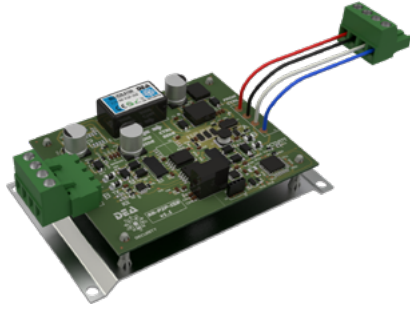

Electronic board which galvanically isolates the CU-FSP2P control unit from the sensor-strings connected to a bus. It prevents possible electric problems (interferences, overvoltages, shortcircuits or earth issues) from propagating from the control board to the sensor bus and viceversa.

COMPLIANCE

IF CONNECTED TO CU-FSP2P OR CU-FSP2P-ISB:

- **Directive 2014/30/EU (EMC)**
 - EN 50130-4:2011+A1:2014
 - EN 61000-6-3:2021
- **Directive 2011/65/EU (RoHS)**
 - EN 50581:2012
- **CEI 79-2 (2nd edition)**

TECHNICAL FEATURES

- **Dimensions:** 105 x 65 x 34 mm (W x H x D)
- **Net weight:** 45 g
- **Power supply:** 24 Vdc (+/- 25%)
- **Current:** 150 mA (max - load 150 sensors)
- **Isolation withstand voltage:** 1.5 KV per 60 seconds
- **Operating temperature:** -40 ÷ +85 °C
- **Relative humidity:** <95% non condensing
- **Inputs:** from BR-FSP2PLT-CTRL
- **Output:** to sensors BUS



The isolator must be always installed inside a case protecting against opening (e.g.: polyester cabinet or junction box).



The CU-FSP2P-ISB control units include two isolators, one each bus, therefore they do not need this board.



The board isolates a single sensor bus.

PART NUMBER	DESCRIPTION
BR-P2P-ISB	Isolator

PAIR OF EASY-PLUG CONNECTORS

PART NUMBER
CN-FSP2P



Pair of 6-contact easy-plug connectors for SN-FSP2P or SN-FSP2P-A sensors prewired in a string.

COMPLIANCE

- CEI 60512-4
- UL94-V0, UL 1977
- MIL-C-26482, MIL-STD1344
- RoHS

TECHNICAL FEATURES

- **Connector type:** 6-pin female circular plug with bayonet locking
- **Dimensions:** 26.2 x 63.2 mm (Ø max x L)
- **Operating temperature:** -40 ÷ +105 °C
- **Housing material:** thermoplastic resistant to UV rays, mineral oils, hydrocarbons and acids
- **IP rating:** IP68
- **Colour:** black



The item CN-FSP2P can be sold only in conjunction with a customized string of SN-FSP2P sensors. The two connectors will be supplied mounted at the two ends of the string.

PART NUMBER	DESCRIPTION	COLOUR
CN-FSP2P	Pair of easy-plug female connectors equipped with assembly form	BLACK



Dual-tech sensor with embedded electronics, prewired in an unconnectorized sensor-string. It can be supplied singularly or prewired with other sensors for customized sensor-strings or for the use as spare part.

COMPLIANCE

SENSOR (if connected to CU-FSP2P or BR-FSP2PLT-CTRL):

- **Directive 2014/30/EU (EMC)**
 - EN 50130-4:2011+A1:2014
 - EN 61000-6-3:2007+A1:2011
- **Directive 2011/65/EU (RoHS)**
 - EN 50581:2012
- **CEI 79-2 (2nd edition)**

CONNECTION CABLE: please see CB-FSP2P on page 58.

TECHNICAL FEATURES

SENSOR:

- **Environmental class:** IV (designed in accordance with Directive EN 50130-5)
- **Dimensions:** 98 x 85 x 26 mm (W x H x D)
- **Material:** glass fiber reinforced polyamide housing
- **Colour:** black
- **Fastening system:** aluminium nut
- **Power supply:** through FSP2P BUS (24 Vdc)
- **Current:** 0.8 mA (stand by) / 1 mA (max)
- **Operating temperature:** -40 ÷ +80 °C
- **Relative humidity:** <95% non condensing
- **IP rating:** IP67 (vertical positioning as per installation specifications)
- **Coverage area:** for each sensor up to 25 m² (5 x 5 m)

CONNECTION CABLE: please see CB-FSP2P on page 58.



The strings composed of SN-FSP2P sensors are unconnectorized, therefore we suggest ordering them together with the pair of CN-FSP2P connectors: in this way the string will be supplied equipped with connectors for an easy junction to JDVP-SP2P and/or TDVP-FSP2P devices. If the easy-plug connectors are not ordered, the JBX-P2P and/or TBX-P2P cases shall be used.



Up to 4 SN-FSP2P connectors can be ordered for each prewired string: as a matter of fact customized strings from 1 to 4 sensors enable you to obtain, by themselves or joined to LN-FSP2P or LN-FSP2P-A strings, any length different from the standard one.



If the sensors are installed at less than their standard spacing (3 metres or 5 metres), the distance covered by the prewired string decreases accordingly.



The sensor-string are to be fixed to the fence by means of FPA-150 tie-wraps.

FUSION P2P sensor is available in the following versions:

PART NUMBER	DESCRIPTION	SENSOR SPACING	COLOUR
SN-FSP2P-300	Sensor prewired in an unconnectorized string	3 m	BLACK
SN-FSP2P-500	Sensor prewired in an unconnectorized string	5 m	BLACK

NEW



Dual-tech sensor with built-in analysis unit prewired in an unconnectorized detection string equipped with armoured cable. It can be supplied singularly, prewired with other sensors in a customized string or as spare part.

COMPLIANCE

SENSOR (if connected to CU-FSP2P or BR-FSP2PLT-CTRL):

- **Directive 2014/30/EU (EMC)**
 - EN 50130-4:2011+A1:2014
 - EN 61000-6-3:2007+A1:2011
- **Directive 2011/65/EU (RoHS)**
 - EN 50581:2012
- **CEI 79-2 (2nd edition)**

CONNECTION CABLE: please see CB-FSP2P-A on page 59.

TECHNICAL FEATURES

SENSOR:

- **Environmental class:** IV (designed in accordance with Directive EN 50130-5)
- **Dimensions:** 98 x 85 x 26 mm (W x H x D)
- **Material:** glass fiber reinforced polyamide housing
- **Colour:** black
- **Fastening system:** aluminium nut
- **Power supply:** through FSP2P BUS (24 Vdc)
- **Current:** 0.8 mA (stand by) / 1 mA (max)
- **Operating temperature:** -40 ÷ +80 °C
- **Relative humidity:** <95% non condensing
- **IP rating:** IP67 (vertical positioning as per installation specifications)
- **Coverage area:** for each sensor up to 25 m² (5 x 5 m)

CONNECTION CABLE: please see CB-FSP2P-A on page 59.



The strings composed of SN-FSP2P-A sensors are unconnectorized, therefore we suggest ordering them together with the pair of CN-FSP2P connectors: in this way the string will be supplied equipped with connectors for an easy junction to JDVP-SP2P and/or TDVP-FSP2P devices. If the easy-plug connectors are not ordered, the JBX-P2P and/or TBX-P2P cases shall be used.



Up to 4 SN-FSP2P-A connectors can be ordered for each prewired string: as a matter of fact customized strings from 1 to 4 sensors enable you to obtain, by themselves or joined to LN-FSP2P or LN-FSP2P-A strings, any length different from the standard one.



If the sensors are installed at less than their standard spacing (3 metres or 5 metres), the distance covered by the prewired string decreases accordingly.



The sensor-string are to be fixed to the fence by means of FPA-150 tie-wraps.

FUSION P2P sensor with armoured cable is available in the following versions:

PART NUMBER	DESCRIPTION	SENSOR SPACING	COLOUR
SN-FSP2P-300A	Sensor with armoured cable prewired in an unconnectorized string	3 m	BLACK
SN-FSP2P-500A	Sensor with armoured cable prewired in an unconnectorized string	5 m	BLACK

APPLICATION EXAMPLES

INSTALLATION OF A FUSION P2P SENSOR-STRING

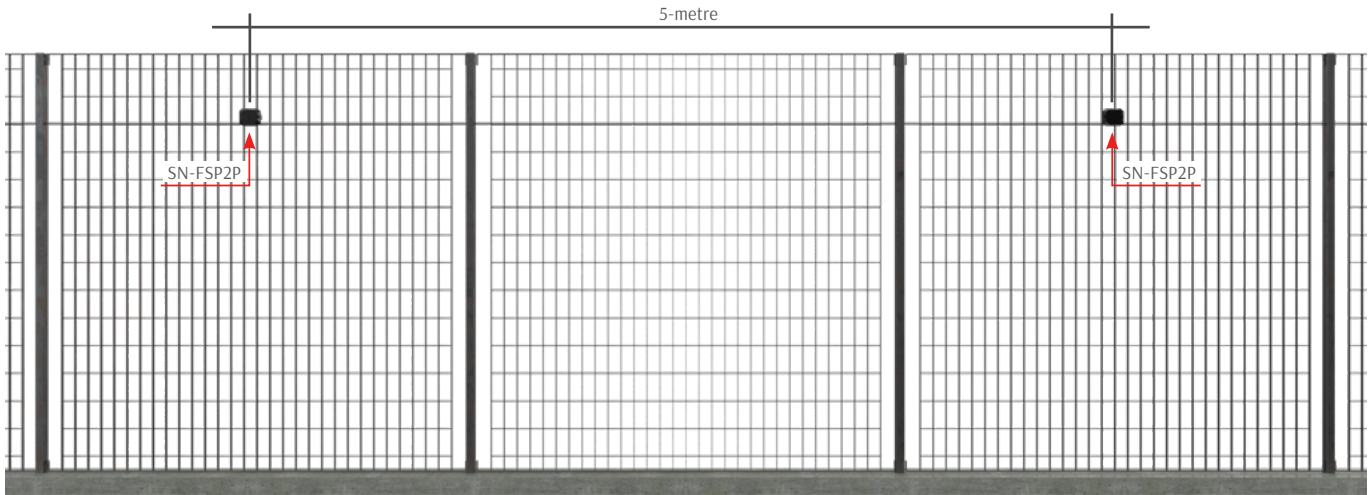

HOW TO FIX SN-FSP2P SENSOR TO THE FENCE



BUS CONFIGURATION WITH CONTROL UNIT

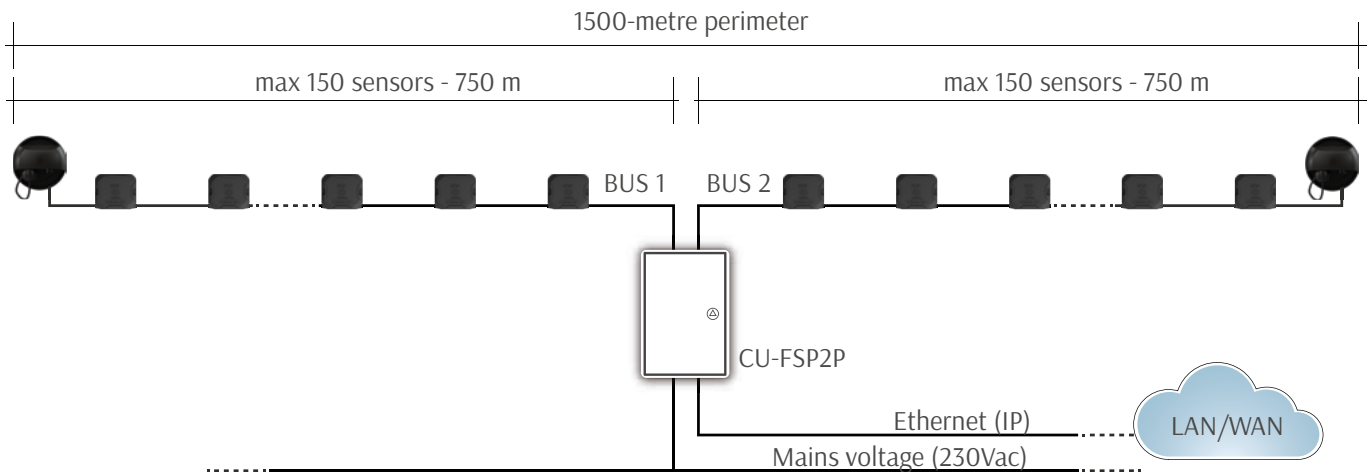

LOOP CONFIGURATION WITH CONTROL UNIT

150 sensors 5-metre spacing in loop configuration for 750 metres of perimeter

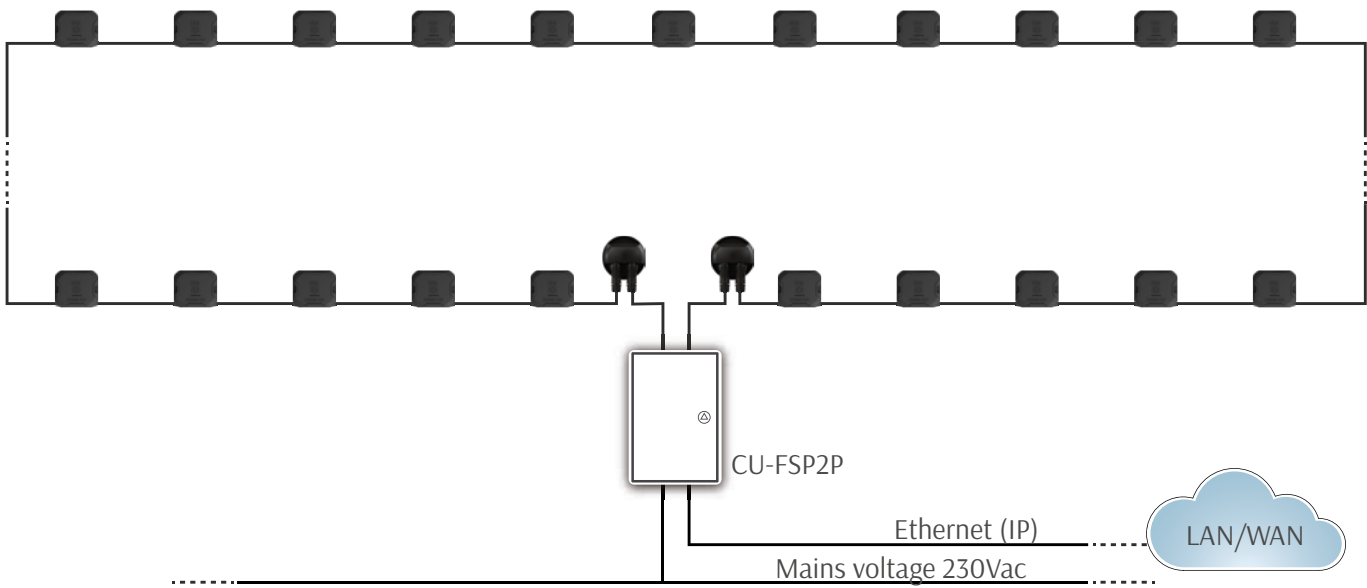

BUS CONFIGURATION WITH BR-FSP2PLT-CTRL CONTROL BOARD

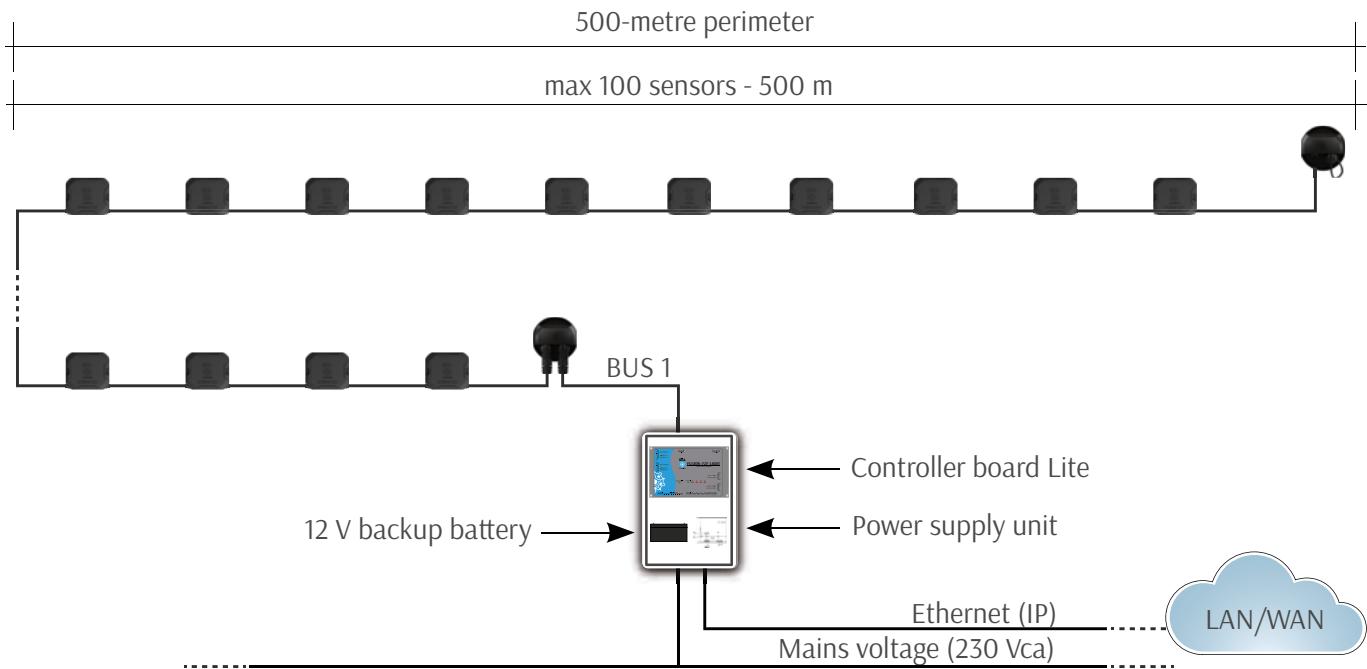

TYPES OF STRING CONNECTION

EXAMPLE 1: CONTROL BOARD PLACED NOT MORE THAN 5 METRES FROM THE FIRST SENSOR-STRING OF THE BUS

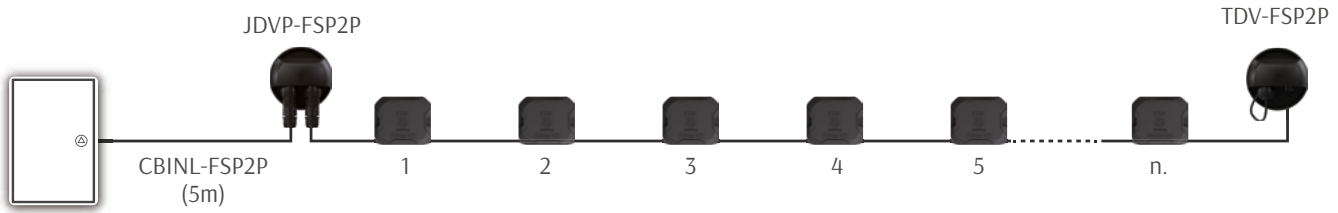

EXAMPLE 2: CONTROLLER BOARD PLACED MORE THAN 5 METRES FROM THE FIRST SENSOR-STRING OF THE BUS

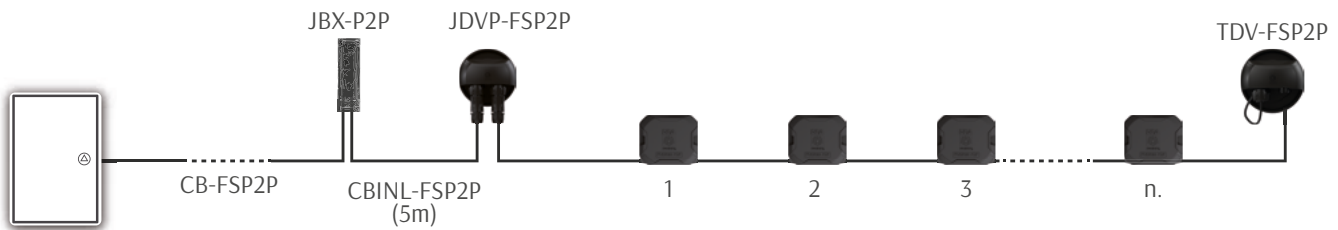

EXAMPLE 3: BYPASS IN THE SENSOR-STRING TO OVERCOME AN OBSTACLE OR A DISCONTINUITY ALONG THE FENCE

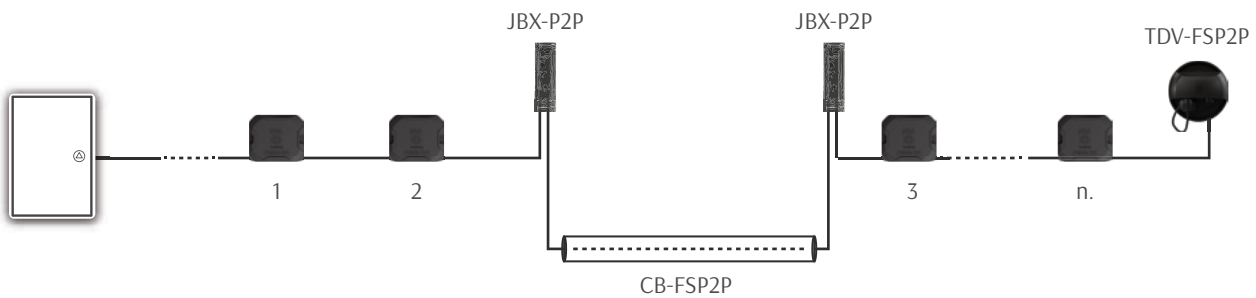

EXAMPLE 4: BYPASS IN THE SENSOR-STRING TO OVERCOME AN OBSTACLE OR A DISCONTINUITY ALONG THE FENCE

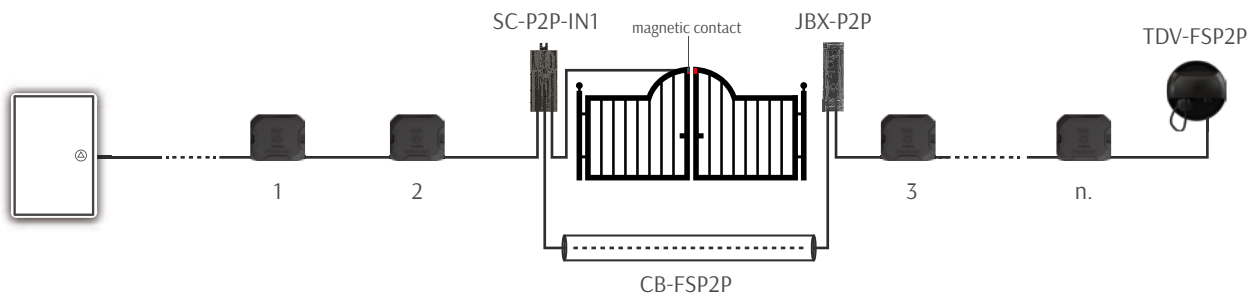

EXAMPLE OF PROTECTION OF A 2.650-METRE FENCE

The site to be protected is enclosed on its 4 sides by a 2.650-metre fence composed of welded mesh fence panels with 5-metre spacing from post to post. One sliding gate is present along the perimeter. Both of the control units are placed in the field, less than 5 metres away from the first sensor-string of each bus. The system is centralized over IP network and it is managed by DEA MAP supervision system.

- **FENCE PROTECTION:**

- no. 35 LN15-FSP2P-500 sensor-strings with 15 detectors each (75 metres);
- no. 1 LN5-FSP2P-500 sensor-string with 5 detectors (25 metres);
- no. 2 CU-FSP2P control units.

- **GATE PROTECTION:**

- no. 1 SC-P2P-IN1 interface module for the integration of magnetic contacts or other third-party devices employed in the protection of the gate.

- **CENTRALIZATION SYSTEM:**

- over TCP/IP network by means of Ethernet ports aboard the control unit.

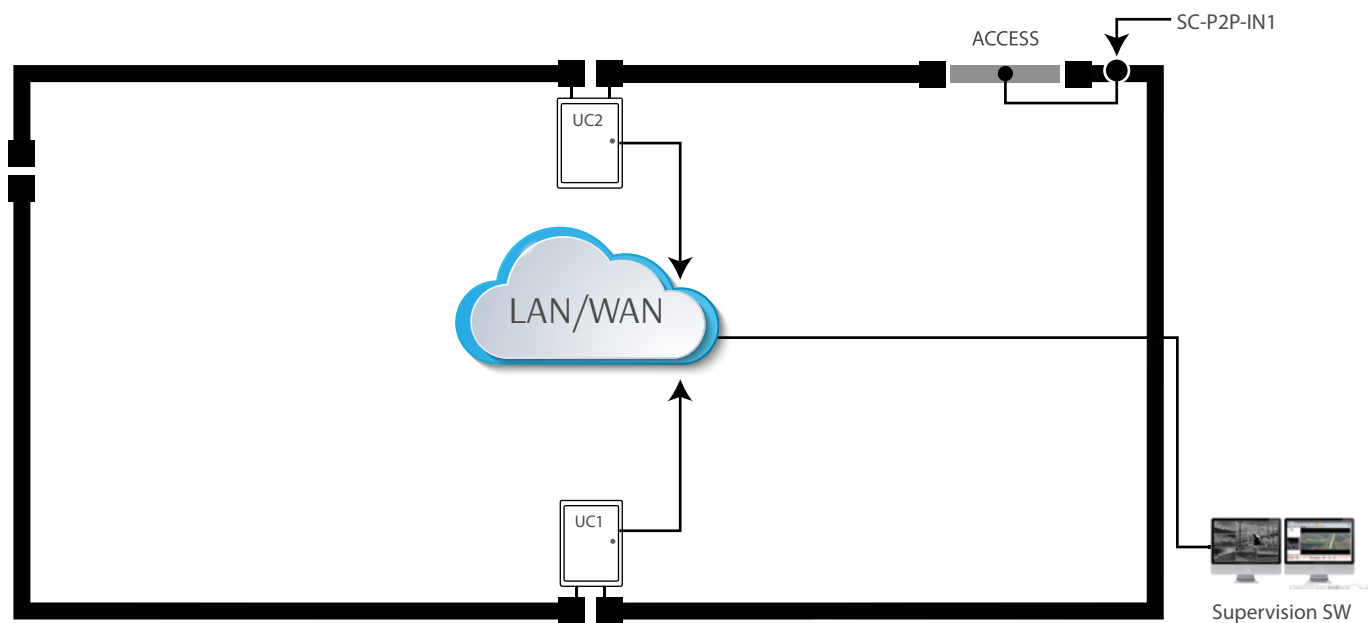

LIST OF PARTS TO MAKE A SYSTEM AS PER THE ABOVE EXAMPLE:

Sensor-strings, connection cable and wiring gateries

Q.TY	PART NUMBER	DESCRIPTION
35	LN15-FSP2P-500	Sensor-string with 15 sensors, 5m spacing
1	LN5-FSP2P-500	Sensor-string with 5 sensors, 5m spacing
4	CBINL-FSP2P	Initial string cable
106	FPA-150	UV resistant, self-locking tie-wraps
36	JDVP-FSP2P	Connectorized junction
4	TDV-FSP2P	Connectorized termination
1	JBX-P2P	Junction unconnectorized sensor-strings
1	SC-P2P-IN1	Peripheral interface module
2	RP-100	Two-component PUR cast resin for peripheral interface module insulation

control unit

Q.TY	PART NUMBER	DESCRIPTION
2	CU-FSP2P	Control Unit

EXAMPLE OF PROTECTION OF A 250-METRE FENCE

The site to be protected is enclosed on its 4 sides by a 250-metre fence composed of welded mesh fence panels with 3-metre spacing from post to post. One sliding gate is present along the perimeter. The control board is placed indoors, near the control panel, and communicates through NC relays.

• **FENCE PROTECTION:**

- no. 3 LN25-FSP2P-300 sensor-strings with 25 sensors each (75 metres);
- no. 2 LN5-FSP2P-300 sensor-strings with 5 sensors each (15 metri) ;
- no. 1 controller board Lite BR-FSP2PLT-CTRL;

• **GATE PROTECTION:**

- no. 1 SC-P2P-IN1 interface module for the integration of magnetic contacts or other third-party devices employed in the protection of the gate.

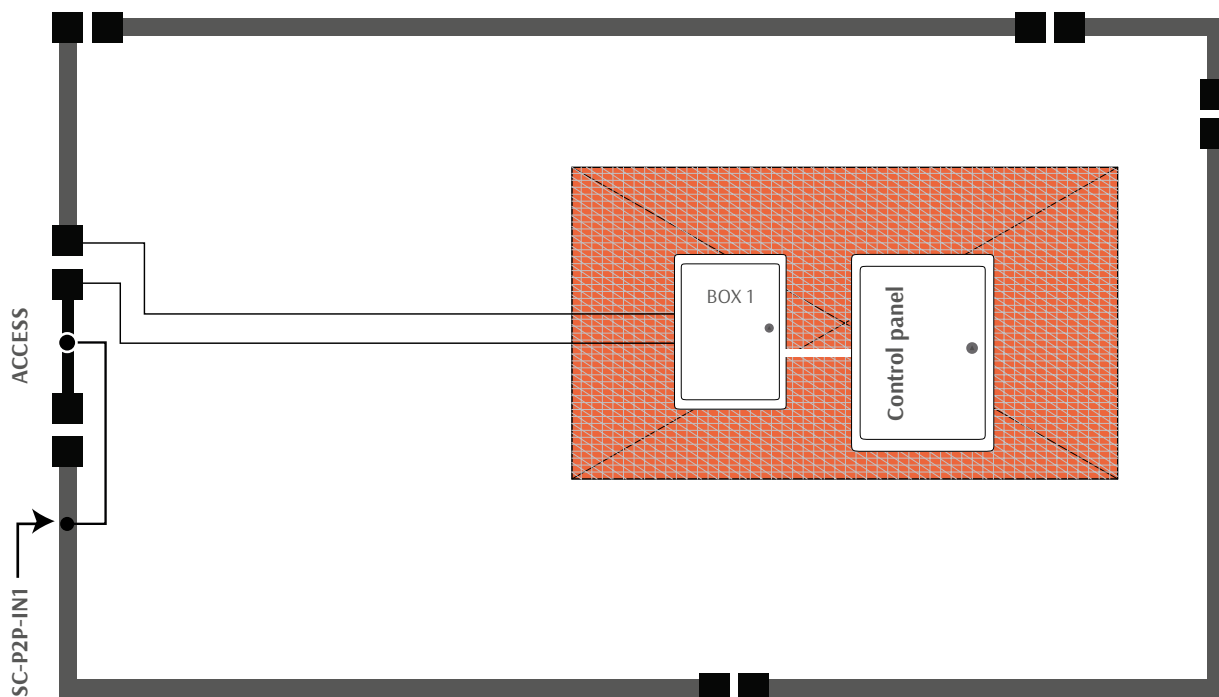

LIST OF PARTS TO MAKE A SYSTEM AS PER THE ABOVE EXAMPLE:

Sensor-strings, connection cable and wiring gateries

Q.TY	PART NUMBER	DESCRIPTION
3	LN25-FSP2P-300	Sensor-string with 25 sensors, 3m spacing
2	LN5-FSP2P-300	Sensor-string with 5 sensors, 3m spacing
1	CB-FSP2P-50	Connection cable between the sensor-string and the processing board
1	CBINL-FSP2P	Initial string cable
10	FPA-150	UV resistant, self-locking tie-wraps
5	JDVP-FSP2P	Connectorized junction
1	TDV-FSP2P	Connectorized termination
2	JBX-P2P	Junction unconnectorized sensor-strings
1	SC-P2P-IN1	Peripheral interface module
3	RP-100	Two-component PUR cast resin for peripheral interface module insulation

Control Unit

Q.TY	PART NUMBER	DESCRIPTION
1	AP-1C	Preassembled polyester cabinet - 400 x 500 x 200 mm (W x H x D)
1	BR-FSP2PLT-CTRL	Control board "Lite"
1	AL-20	Microprocessor stabilized linear power supply unit 2.5 A - 13.8 Vdc

OUTDOOR SYSTEMS

SERIR

PIEZODYNAMIC SYSTEMS FOR FLEXIBLE METAL FENCES

SERIR is a line of perimeter intrusion detection systems dedicated to the protection of chain link or welded mesh fences and semi-rigid panels.

SERIR employs sensors with a piezodynamic transducer and detects cut, climb and break-through attempts.

- **SERIR 50**

It employs piezodynamic passive sensors supplied in prewired strings up to 50 metres long. The electronics is aboard special processing boards managing up to 200 metres of perimeter (for the four-zone version of the boards).

- **SERIR COMPACT 50**

Compact version of SERIR 50 system supplied in ready-to-use kits to cover 50 metres of perimeter. A special expansion kit allows you to cover up to 100 metres with a single Analysis Unit.

SERIR 50

SERIR 50

Prewired sensor-string, 50 metres long. One string can be composed of 25, 20 or 16 SN-SR50 sensors according to the post-to-post distance which can be 2, 2.5 or 3 metres.

TECHNICAL FEATURES

Please see SN-SR50 on page 87.



The LN-SR50 sensor-string must be connected to either BR-SR50-Z2 or BR-SR50-Z4 processing board by means of CB-ST50 cable which must have a maximum length of 150 metres.



Should you need sensor-strings with customized lengths (less than 50 metres), you have to order the needed number of SN-SR50 sensors referring to the part number table on page 87. These sensors are supplied prewired in a string.

SERIR 50 sensor-string is available in the following versions:

PART NUMBER	DESCRIPTION	SENSOR SPACING	NO. OF SENSORS EACH STRING	COLOUR
LN25-SR50-200	Prewired sensor-string	2 m	25	BLACK
LN20-SR50-250	Prewired sensor-string	2.5 m	20	BLACK
LN16-SR50-300	Prewired sensor-string	3 m	16	BLACK



Piezodynamic sensor prewired in a sensor-string with customized length (less than 50 metres) and with 2m, 2.5m or 3m distance between the sensors.

COMPLIANCE

SENSOR (if connected to BR-SR50-Z2 or BR-SR50-Z4):

- **Directive 2014/30/EU (EMC)**
 - EN 50130-4:2011+A1:2014
 - EN 61000-6-3:2007+A1:2011
- **Directive 2011/65/EU (RoHS)**
 - EN 50581:2012
- **CEI 79-2 (2nd edition)**

CONNECTION CABLE: please see CB-ST50 on page 90.

TECHNICAL FEATURES

SENSOR:

- **Environmental class:** IV (designed in accordance with Directive EN 50130-5)
- **Dimensions:** 85 x 45 mm (Ø x H)
- **Material:** glass fibre reinforced ABS housing, sealed with epoxy and UV resistant
- **Fastening system:** powder-coated galvanized iron back mounting plate
- **Colour:** black
- **Operating temperature:** -40 ÷ +80 °C
- **Relative humidity:** 0 – 100%
- **IP rating:** IP68
- **Coverage area:** up to 9 m² (3 x 3 m - maximum dimensions of the fence panel with sensor in mid-position)

CONNECTION CABLE: please see CB-ST50 on page 90.



The sensor-string composed of SN-SR50 sensors must be connected to either BR-SR50-Z2 or BR-SR50-Z4 processing board by means of CB-ST50 cable which must have a maximum length of 150 metres.

SERIR 50 sensor is available in the following versions:

PART NUMBER	DESCRIPTION	SENSOR SPACING	MAX NO. OF SENSORS EACH STRING	COLOUR
SN-SR50-200	Sensor prewired in a sensor-string	2 m	25	BLACK
SN-SR50-250	Sensor prewired in a sensor-string	2.5 m	20	BLACK
SN-SR50-300	Sensor prewired in a sensor-string	3 m	16	BLACK

Prewired sensor-string of 50-metre length, with cable protected by flexible metal tube. One string can be composed of 25, 20 or 16 SN-SR50-GM sensors according to the post-to-post distance which can be 2, 2.5 or 3 metres.

TECHNICAL FEATURES

Please see SN-SR50-GM on page 89.



The LN-SR50-GM sensor-string must be connected to either BR-SR50-Z2 or BR-SR50-Z4 processing board by means of CB-ST50 cable which must have a maximum length of 150 metres.



Should you need sensor-strings with customized lengths (less than 50 metres), you have to order the needed number of SN-SR50-GM sensors referring to the part number table on page 89. These sensors are supplied prewired in a string.

SERIR 50 sensor-string with cable protected by flexible metal tube is available **ON REQUEST**.

PART NUMBER	DESCRIPTION	SENSOR SPACING	NO. OF SENSORS EACH STRING	COLOUR
LN25-SR50-GM200	Prewired sensor-string with metal tube	2 m	25	BLACK
LN20-SR50-GM250	Prewired sensor-string with metal tube	2.5 m	20	BLACK
LN16-SR50-GM300	Prewired sensor-string with metal tube	3 m	16	BLACK



SN-SR50 sensor prewired sensor-string of 50-metre length with connection cable protected by flexible metal tube for a higher mechanical resistance.

COMPLIANCE

SENSOR (if connected to BR-SR50-Z2 or BR-SR50-Z4):

- **Directive 2014/30/EU (EMC)**
 - EN 50130-4:2011+A1:2014
 - EN 61000-6-3:2007+A1:2011
- **Directive 2011/65/EU (RoHS)**
 - EN 50581:2012
- **CEI 79-2 (2nd edition)**

CONNECTION CABLE: please see CB-ST50 on page 90.

TECHNICAL FEATURES

SENSOR:

- **Environmental class:** IV (designed in accordance with Directive EN 50130-5)
- **Dimensions:** 85 x 45 mm (Ø x H)
- **Material:** glass fibre reinforced ABS housing, sealed with epoxy and UV resistant
- **Colour:** black
- **Mounting plate:** powder-coated galvanized iron back mounting plate
- **Operating temperature:** -40 ÷ +80 °C
- **Relative humidity:** 0 – 100%
- **IP rating:** IP68
- **Coverage area:** max 9 m² (3 x 3 m - maximum dimensions of the fence panel with sensor in mid-position)

CONNECTION CABLE: please see CB-ST50 on page 90.

JACKET:

- **Diameter:** 10 mm vacuum covered
- **Material:** galvanized steel with single seam and PVC
- **Colour:** black



The sensor-string composed of SN-SR50 sensors must be connected to either BR-SR50-Z2 or BR-SR50-Z4 processing board by means of CB-ST50 cable which must have a maximum length of 150 metres.

SERIR 50 sensor with cable protected with flexible metal tube is available **ON REQUEST**.

PART NUMBER	DESCRIPTION	SENSOR SPACING	MAX NO. OF SENSORS EACH STRING	COLOUR
SN-SR50-GM200	Sensor prewired in a string and with cable protected by flexible metal tube	2 m	25	BLACK
SN-SR50-GM250	Sensor prewired in a string and with cable protected by flexible metal tube	2.5 m	20	BLACK
SN-SR50-GM300	Sensor prewired in a string and with cable protected by flexible metal tube	3 m	16	BLACK



Tinned copper two-wire shielded cable for the connection of LN-SR50 sensor-string or SN-SR50 and SN-SR50-GM sensors prewired in a string to either BR-SR50-Z2 or BR-SR50-Z4 processing board.

COMPLIANCE

- Directive 2006/95/CE
- CEI 20-11, CEI 20-14 p.q.a., CEI 20-35/1-2
- EN 50363, EN 60332-1-2
- IEC 60332-1
- UL 1581
- RoHS
- REACH

TECHNICAL FEATURES

- **Diameter:** 6.2 mm
- **Conductors:** 2 twisted tinned copper wires
- **Cross sectional area:** 0.25 mm² (24 AWG)
- **Operating temperature:**
 - -40 ÷ +80 °C (fixed installation)
 - -15 ÷ +80 °C (mobile installation)
- **Installation temperature:** -15 ÷ +50 °C
- **Insulation voltage:** 0.6/1 kV
- **Wire insulation material:** polyolefin
- **Shielding:**
 - tinned copper braid (coverage >90%)
 - Aluminium/Polyester foil screen (coverage >100%) with tinned copper drain wire with cross sectional area of sect. 0.25 mm² (24 AWG)
- **Double jacket:** special flame retardant PVC compound, quality TM2/RZ
- **Bending radius:** 15 times outer diameter
- **Use:** this cable can be installed in a group of cables with max operating voltage of U_o/U 0.6/1 kV
- **Colour:** black

SERIR 50/TORSUS 50 cable is available in hanks of 25, 50, 100, 200 metres and in reels of 500 metres.

PART NUMBER	DESCRIPTION	LENGTH	COLOUR
CB-ST50-25	Connection cable	25 m	BLACK
CB-ST50-50	Connection cable	50 m	BLACK
CB-ST50-100	Connection cable	100 m	BLACK
CB-ST50-200	Connection cable	200 m	BLACK
CB-ST50-500	Connection cable	500 m	BLACK



UV resistant polyamide case for junction and termination of SERIR 50 sensor-strings.
Supplied with a printed circuit board to simplify the wiring procedures.

COMPLIANCE

IF CONNECTED TO LN-SR50 or LN-SR50-GM:

- **Directive 2014/30/EU (EMC)**
 - EN 50130-4:2011+A1:2014
 - EN 61000-6-3:2007+A1:2011
- **Directive 2011/65/EU (RoHS)**
 - EN 50581:2012

TECHNICAL FEATURES

- **Environmental class:** IV (designed in accordance with Directive EN 50130-5)
- **Dimensions:** 30 x 114 x 30 mm (W x H x D)
- **Gross weight:** 64 g
- **Net weight:** 60 g
- **Material:** glass fiber reinforced polyamide PA6-GF30
- **Colour:** black
- **Operating temperature:** -40 ÷ +80 °C
- **Relative humidity:** 0 - 100% (after sealing with RP-100 PUR cast resin)



To be wired with CB-ST50 or CV-ST50-P cable and to be sealed with RP-100 two-component PUR cast resin.

PART NUMBER	DESCRIPTION	COLOUR
JTBX-ST50	Junction/Termination case	BLACK



Electronic processing board which manages two SERIR 50 sensor-strings.

It amplifies, digitizes and analyzes the signals coming from the sensors, discriminating the typical signals of an intrusion from those generated by environmental nuisances. The board is equipped with Ethernet interface and IP native support.

COMPLIANCE

IF CONNECTED TO LN-SR50 OR LN-SR50-GM:

- **Directive 2014/30/EU (EMC)**
 - EN 50130-4:2011+A1:2014
 - IEC 61000-6-4:2018
- **Directive 2011/65/EU (RoHS)**
 - EN 50581:2012
- **CEI 79-2 (2nd edition)**

TECHNICAL FEATURES

- **Dimensions:** 160 x 86 x 40 mm (W x H x D)
- **Packaging dimensions:** 200 x 100 x 45 mm (W x H x D)
- **Gross weight:** 410 g
- **Net weight:** 240 g
- **Power supply:** 12 Vdc (+/- 25%)
- **Current:** 110 mA (max)
- **Operating temperature:** -25 ÷ +80 °C
- **Relative humidity:** <95% non condensing
- **Management capability (each line):** up to 25 SERIR 50 detectors
- **Inputs:**
 - 2 analog for sensor-strings with resistor balancing
 - 2 digital opto-isolated, configurable by service software
- **NC relay outputs (positive security):**
 - 2 for alarm sensor-strings 1, 2
 - 2 for tampering sensor-strings 1, 2
 - 1 Low supply voltage/ Service Active/No Operating Software
- **OC outputs:** 2 for prealarm and/or Sporadic Cut Alarm
- **Communication port:**
 - USB (PC link)
 - Ethernet (RJ45)
 - DEA NET bus
- **Calibration, settings and event management via software**
- **CPU:** 32 bit, 168 MHz
- **Digital memory:** more than 20.000 events
- **Service software licence included**

PART NUMBER	DESCRIPTION
BR-SR50-Z2	Dual-zone processing board

4-ZONE PROCESSING BOARD

PART NUMBER
BR-SR50-Z4



Electronic processing board which manages four SERIR 50 sensor-strings.

It amplifies, digitizes and analyzes the signals coming from the sensor-strings, discriminating the typical signals of an intrusion from those generated by environmental nuisances. The board is equipped with Ethernet interface and IP Native support.

COMPLIANCE

IF CONNECTED TO LN-SR50 OR LN-SR50-GM:

- **Directive 2014/30/EU (EMC)**
 - EN 50130-4:2011+A1:2014
 - IEC 61000-6-4:2018
- **Directive 2011/65/EU (RoHS)**
 - EN 50581:2012
- **CEI 79-2 (2nd edition)**

TECHNICAL FEATURES

- **Dimensions:** 200 x 130 x 40 mm (W x H x D)
- **Packaging dimensions:** 240 x 175 x 65 mm (W x H x D)
- **Gross weight:** 668 g
- **Net weight:** 378 g
- **Power supply:** 12 Vdc (+/- 25%)
- **Current:** 130 mA (max)
- **Operating temperature:** -25 ÷ +80 °C
- **Relative humidity:** <95% non condensing
- **Management capability (each line):** up to 25 SERIR 50 detectors
- **Inputs:**
 - 4 analog for sensor-strings with resistor balancing
 - 4 digital opto-isolated programmable da software
- **NC relay outputs (positive security):**
 - 4 for alarm sensor-strings 1, 2, 3, 4
 - 4 for tampering sensor-strings 1, 2, 3, 4
 - 1 Low supply voltage/ Service Active/No Operating Software
 - 4 programmable for prealarm and/or Sporadic Cut Alarm
- **Communication port:**
 - USB (PC link)
 - Ethernet (RJ45)
 - DEA NET bus
- **Calibration, settings and event management via software**
- **CPU:** 32 bit, 168 MHz
- **Digital memory:** more than 20.000 events
- **Service software licence included**

SERIR 50

PART NUMBER	DESCRIPTION
BR-SR50-Z4	Four-zone processing board

1-RELAY EXPANSION BOARD

PART NUMBER
SC-ER1

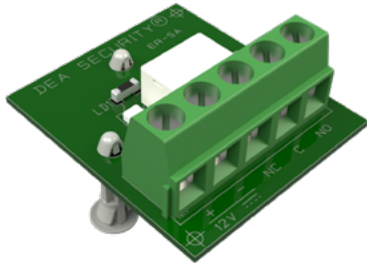

1-relay expansion board to convert OC outputs into C/NC/NO contacts.

COMPLIANCE

IF CONNECTED TO BOARDS WHICH PROVIDE FOR ITS USE:

- Directive 2014/30/EU (EMC)

TECHNICAL FEATURES

- **Dimensions:** 36 x 32 x 31 mm (W x H x D)
- **Gross weight:** 13 g
- **Power supply:** 12 Vdc (+/- 25%)
- **Current:** 12 mA
- **Operating temperature:** -25 ÷ +80 °C
- **Relative humidity:** <95% non condensing
- **Input:** 1 per OC signal
- **NC relay outputs (1 A):** C/NC/NO

PART NUMBER	DESCRIPTION
SC-ER1	1-relay expansion board (OC into C/NC/NO)

APPLICATION EXAMPLES

INSTALLATION OF A SERIR 50 SENSOR-STRING

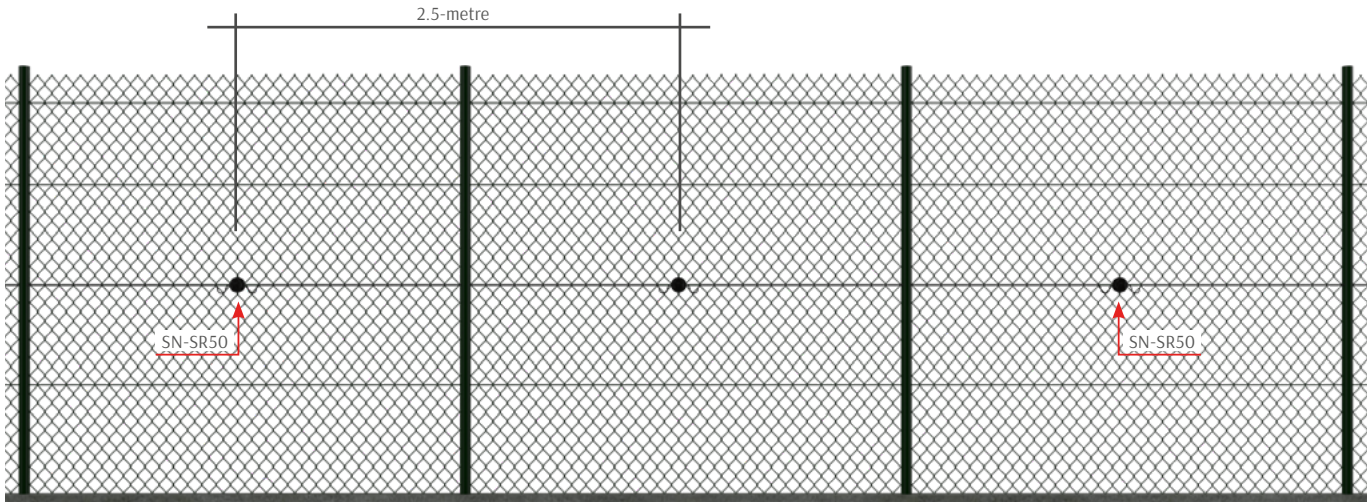

HOW TO FIX AN SN-SR50 SENSOR TO THE FENCE

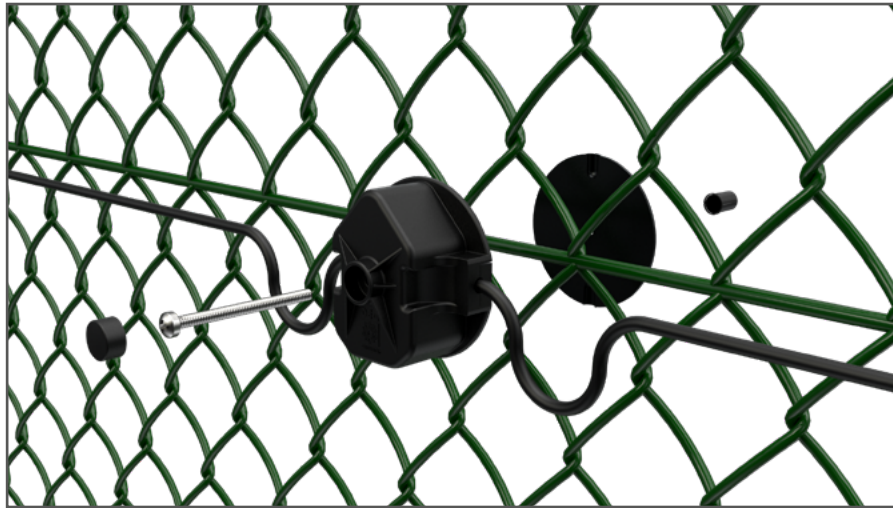

TYPICAL CONFIGURATION OF A SERIR 50 FIELD CABINET (4 ZONES)

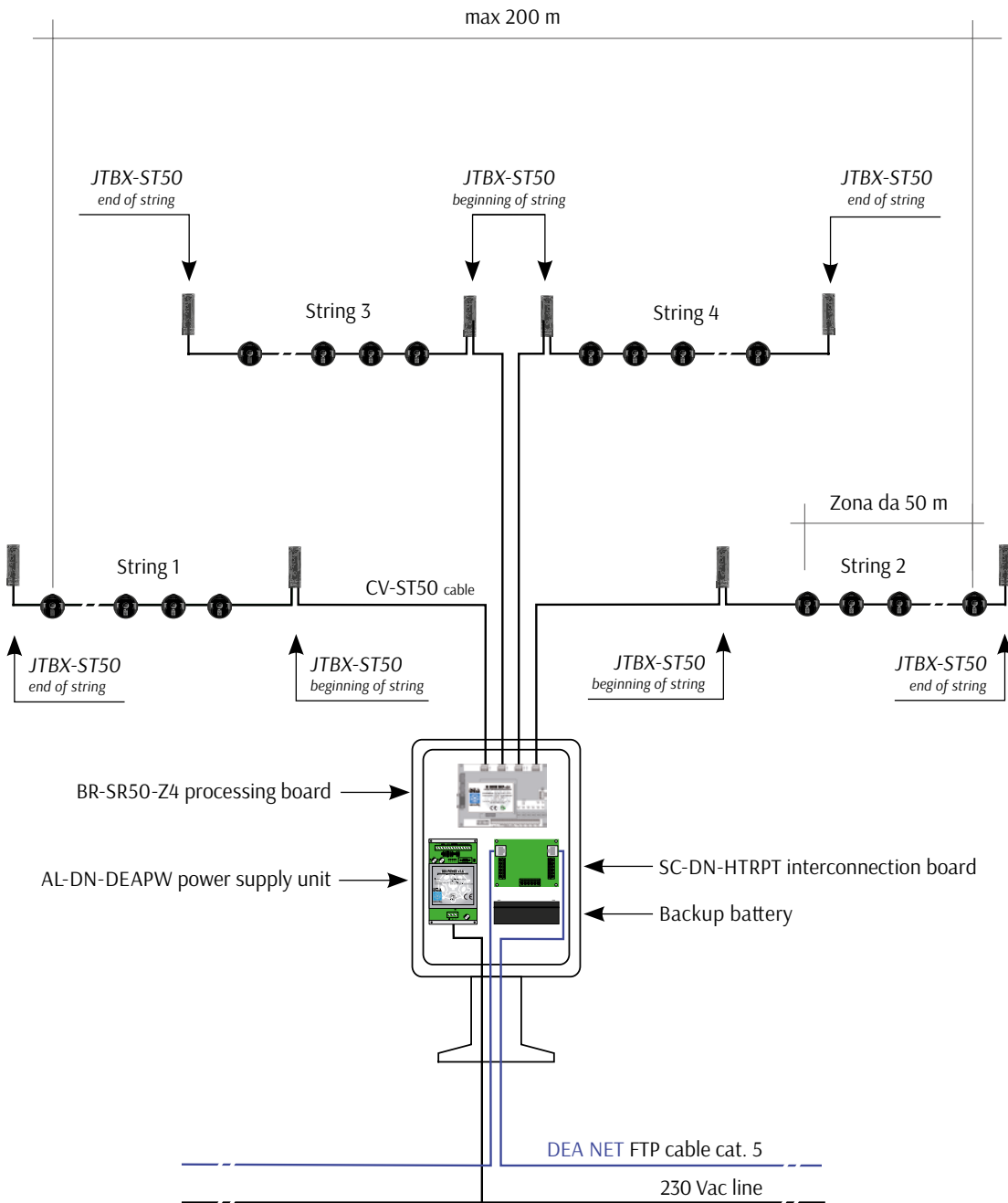

EXAMPLE OF PROTECTION OF A 100-METRE FENCE

The site to be protected is enclosed by a rolled fence with 2 m from post to post and by a sliding gate.

• **FENCE PROTECTION:**

- no. 2 sensor-strings model LN25-SR50-200, corresponding to 2 alarm zones of 50 metres each;
- no. 1 field cabinet (Box1) containing the processing boards and the interface boards.

• **GATE PROTECTION:**

- no. 1 SC-DN-IO interface board to integrate the signals of magnetic contacts.

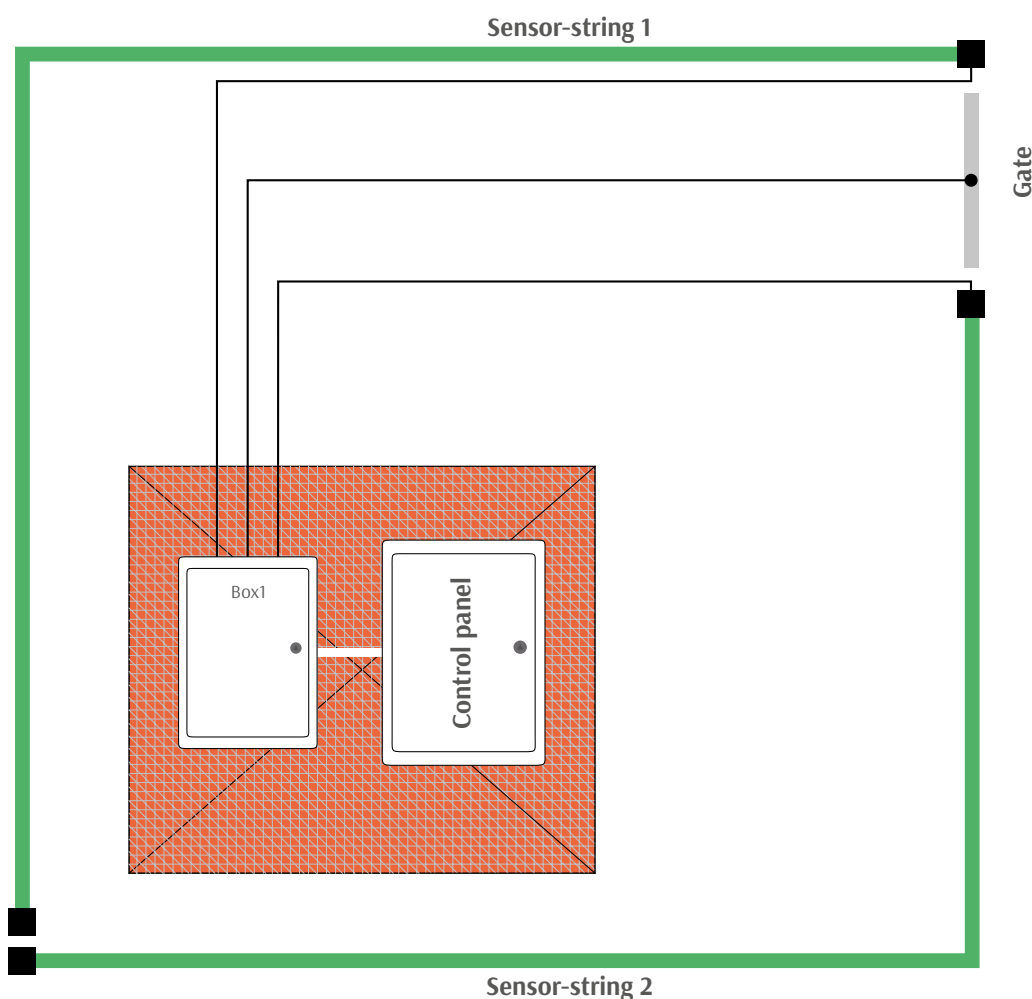

LIST OF PARTS TO MAKE A SYSTEM AS PER THE PREVIOUS EXAMPLE:

Sensor-strings, connection cable and wiring gateries

Q.TY	PART NUMBER	DESCRIPTION
2	LN25-SR50-200	Sensor-string for 2-metre fence panels
1	CB-ST50-100	Connection cable between the sensor-string and the processing board
4	FPA-150	UV resistant, self-locking tie-wraps
4	JTBX-ST50	Junction/termination case
2	RP-100	Two-component PUR cast resin to seal junction and termination cases

Cabinet Box1 and relevant processing boards

Q.TY	PART NUMBER	DESCRIPTION
1	AP-1C	Preassembled polyester cabinet - 400 x 500 x 200 mm (W x H x D)
1	AL-20	Microprocessor stabilized linear power supply unit 2.5 A - 13.8 Vdc
1	BR-SR50-Z2	Dual-zone processing board

SERIR COMPACT 50

SERIR COMPACT 50



Module for the protection of a fence up to 50 metres long. It is composed of a prewired sensor-string of 20 sensors for the protection of fence panels with 2.5 metres width, a preassembled Analysis Unit, a 25-metre hank of cable and a wiring kit.

CONTENTS OF THE BASIC MODULE:

- **UA-SRC50 Analysis Unit:**
 - BOX-C50 polyester cabinet
 - SC-SRC50MAIN processing board
 - SC-C50PW transformer
 - BT-C12 backup battery
- **Prewired sensor-string composed of 20 SN-SR50 sensors with 2.5-metre spacing, colour black**
- **CB-ST50 cable hank, 25 metres long, colour black**
- **KITCB-C50 wiring kit:**
 - 2 packs of FPA-150 tie-wraps (100 pcs each pack)
 - 1 pack of RP-100 two-component PUR cast resin (100g)
 - 2 JTBX-ST50 junction/termination cases

COMPLIANCE

- **Directive 2014/30/EU (EMC)**
 - › EN 50130-4:2011+A1:2014
 - › EN 61000-6-3:2007+A1:2011
- **Directive 2011/65/EU (RoHS)**
 - › EN 50581:2012
- **CEI 79-2 (2nd edition)**
- **IEC 62208, IEC 60695-2-10, IEC 60695-2-11, IEC 60695-11-5**

TECHNICAL FEATURES

- **Weight of the packed module:** approx. 17 Kg
- **For further technical data, please refer to the datasheets of the single devices.**



The sensor-string must be connected to UA-SRC50 Analysis Unit by means of CB-ST50 cable which must have a maximum length of 150 metres.



To cover further 50 metres of perimeter, MD-TRC50EXP Expansion Module can be used.

PART NUMBER	DESCRIPTION	SENSOR SPACING	NO. OF SENSORS EACH STRING	COLOUR
MD-SRC50-250	Basic Module	2.5 m	20	BLACK



Module which allows to protect further 50 metres of perimeter, for 100 metres altogether.

It includes a string prewired with 20 sensors, 2,5m span for the protection of 50 metres, a preassembled analysis unit, a 25-metre reel of cable and a wiring kit.

CONTENTS OF THE EXPANSION MODULE:

- SC-SRC50EXP Expansion board
- Prewired sensor-string composed of 20 SN-SR50 sensors with 2.5-metre spacing, colour black
- CB-ST50 cable hank, 25 metres long, colour black
- KITCB-C50 wiring kit:
 - 2 packs of FPA-150 tie-wraps (100 pcs each pack)
 - 1 pack of RP-100 two-component PUR cast resin (100g)
 - 2 JTBX-ST50 junction/termination cases

COMPLIANCE

IF CONNECTED TO UA-SRC50:

- Directive 2014/30/EU (EMC)
 - EN 50130-4:2011+A1:2014
 - EN 61000-6-3:2007+A1:2011
- Directive 2011/65/EU (RoHS)
 - EN 50581:2012
- CEI 79-2 (2nd edition)

TECHNICAL FEATURES

- Weight of the packed module: approx. 15 Kg
- For further technical data, please refer to the datasheets of the single devices.



The sensor-string must be connected to UA-SRC50 Analysis Unit by means of CB-ST50 cable which must have a maximum length of 150 metres.



To one Basic Module can be connected one Expansion Module only.

PART NUMBER	DESCRIPTION	SENSOR SPACING	NO. OF SENSORS EACH STRING	COLOUR
MD-SRC50EXP-250	Expansion Module	2.5 m	20	BLACK

1-RELAY EXPANSION BOARD

PART NUMBER
SC-ER1

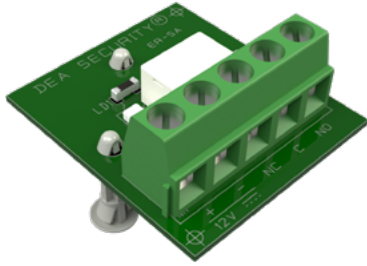

1-relay expansion board to convert OC outputs into C/NC/NO contacts.

COMPLIANCE

IF CONNECTED TO BOARDS WHICH PROVIDE FOR ITS USE:

- Directive 2014/30/EU (EMC)

TECHNICAL FEATURES

- **Dimensions:** 36 x 32 x 31 mm (W x H x D)
- **Gross weight:** 13 g
- **Power supply:** 12 Vdc (+/- 25%)
- **Current:** 12 mA
- **Operating temperature:** -25 ÷ +80 °C
- **Relative humidity:** <95% non condensing
- **Input:** 1 per OC signal
- **NC relay outputs (1 A):** C/NC/NO

PART NUMBER	DESCRIPTION
SC-ER1	1-relay expansion board (OC into C/NC/NO)

SPARE PARTS

Spare parts to integrate or replace the components contained in MD-SRC50 and MD-SRC50EXP modules

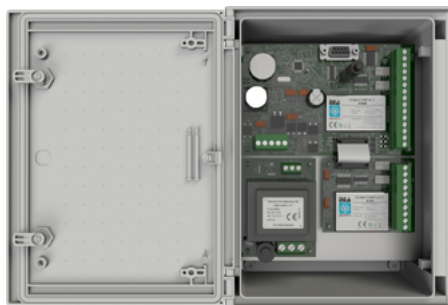

Polyester cabinet preassembled with a processing board (including tamper switch), a transformer and a backup battery.

UA-SRC50 CONTENTS:

- BOX-C50 polyester cabinet
- SC-SRC50MAIN processing board
- SC-C50PW transformer
- BT-C12 backup battery

COMPLIANCE

IF CONNECTED TO LN-SR50:

- **Directive 2014/30/EU (EMC)**
 - EN 50130-4:2011+A1:2014
 - EN 61000-6-3:2007+A1:2011
- **Directive 2014/35/EU (EMC)**
 - EN 60950-1:2006+A11:2009
- **Directive 2011/65/EU (RoHS)**
 - EN 50581:2012
- **CEI 79-2 (2nd edition)**
- **IEC 62208, IEC 60695-2-10, IEC 60695-2-11, IEC 60695-11-5**

TECHNICAL FEATURES

ANALYSIS UNIT:

- **Environmental class:** IV (designed in accordance with Directive EN 50130-5)
- **Dimensions:** 200 x 255 x 135 mm (W x H x D)
- **Net weight:** approx. 2.9 Kg
- **Material:** polyester self-extinguishing housing, provided with ventilation openings
- **IP rating:** IP66 (IP54 with ventilation devices), IK10
- **Power supply:** 230 Vac \pm 10% 50 Hz
- **Max current consumption:** 50 mA
- **Backup battery:** da 12 V, 1.2 Ah
- **Operating temperature:** -25 \div +70 °C
- **Relative humidity:** <95% non condensing

PROCESSING BOARD: please see SC-SRC50MAIN on page 105.

EXPANSION BOARD: please see SC-SRC50EXP on page 106.

PART NUMBER	DESCRIPTION
UA-SRC50	Analysis Unit

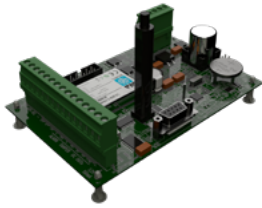

Microprocessor electronic board which manages one SERIR 50 sensor-string. This board amplifies, digitizes and analyses the signals coming from the sensor-string, discriminating the typical signals of an intrusion from the ones generated by environmental nuisances.

COMPLIANCE

ASSEMBLED INSIDE UA-SRC50:

- **Directive 2014/30/EU (EMC)**
 - EN 50130-4:2011+A1:2014
 - EN 61000-6-3:2007+A1:2011
- **Directive 2011/65/EU (RoHS)**
 - EN 50581:2012
- **CEI 79-2 (2nd edition)**

TECHNICAL FEATURES

- **Dimensions:** 90 x 140 mm (B x H)
- **Power supply:** 15 Vac
- **Operating temperature:** -25 ÷ +80 °C
- **Relative humidity:** <95% non condensing
- **Management capability:** up to 25 SERIR 50 sensors
- **Analog inputs:** 1 sensor-string with resistor balancing; max 25 sensors
- **Auxiliary inputs:**
 - reset
 - ARM (event storage)
 - anti-opening tamper (cabinet)
- **NC relay outputs (1 A):**
 - intrusion alarm
 - tamper
- **OC outputs (negative):**
 - prealarm
 - mains loss (230 Vac)
 - battery presence
- **Communication port:**
 - expansion board
 - RS-232 (PC link)
- **Digital memory:** more than 20.000 events
- **Service software licence included**

PART NUMBER	DESCRIPTION
SC-SRC50MAIN	Processing board

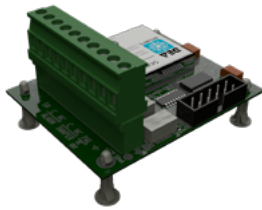

Electronic board which manages a second SERIR 50 sensor-string to protect further 50 metres of perimeter. It must be mounted inside UA-SRC50 Analysis Unit and connected to the processing board.

COMPLIANCE

ASSEMBLED INSIDE UA-SRC50:

- **Directive 2014/30/EU (EMC)**
 - EN 50130-4:2011+A1:2014
 - EN 61000-6-3:2007+A1:2011
- **Directive 2011/65/EU (RoHS)**
 - EN 50581:2012
- **CEI 79-2 (2nd edition)**

TECHNICAL FEATURES

- **Dimensions:** 60 x 75 mm (B x H)
- **Power supply:** 12 Vdc (by flat cable from the processing board)
- **Operating temperature:** -25 ÷ +80 °C
- **Relative humidity:** <95% non condensing
- **Management capability:** up to 25 SERIR 50 sensors
- **Analog inputs:** 1 sensor-string with resistor balancing; max 25 sensors
- **Power outputs:** AUX → 12 Vdc → 50 mA protected by reset fuse F4
- **NC relay outputs (1 A):**
 - intrusion alarm
 - tamper
- **OC outputs (negative):**
 - prealarm



The expansion board cannot work by itself but must be connected to the processing board present inside the Analysis Unit by means of the flat cable provided with it.

PART NUMBER	DESCRIPTION
SC-SRC50EXP	Expansion board

TRANSFORMER

PART NUMBER
SC-C50PW

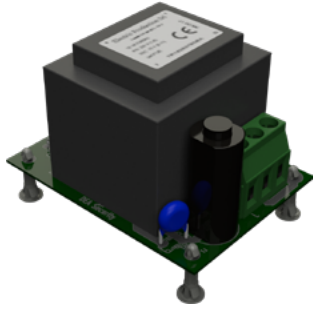

Current transformer inside the Analysis Unit.

COMPLIANCE

ASSEMBLED INSIDE UA-SRC50:

- **Directive 2014/30/EU (EMC)**
 - EN 50130-4:2011+A1:2014
 - EN 61000-6-3:2007+A1:2011

TECHNICAL FEATURES

- **Dimensions:** 60 x 80 mm (B x H)
- **Power supply:** 230 Vac 50/60 Hz
- **Nominal power:** 10 VA
- **Operating temperature:** -25 ÷ +80 °C
- **Relative humidity:** <95% non condensing
- **Nominal input voltage:** Line, Neutral, Earth protected by fuse
- **Output:** 15 Vac

PART NUMBER	DESCRIPTION
SC-C50PW	Transformer

WIRING KIT

PART NUMBER
KITCB-C50



Kit for the sensor-string wiring. Includes two 100-piece packs of FPA-150 tie-wraps for tying the cable to the fence; two JTBX-ST50 cases for sensor-string junction/termination; one pack of RP-100 two-component PUR cast resin (100g) to seal JTBX-ST50 cases.

TECHNICAL FEATURES

Please see JTBX-ST50 on page 91, FPA-150 and RP-100 on page 205.

PART NUMBER	DESCRIPTION
KITCB-C50	Wiring kit

SENSOR-STRINGS

PART NUMBER
LN-SR50

Prewired sensor-string with standard length of 50 metres, composed of 25 SN-SR50 sensors for the protection of fences with 2,5 metre post-to-post distance..

TECHNICAL FEATURES

Please see SN-SR50 on page 87.



The LN-SR50 sensor-string must be connected to either BR-SR50-Z2 or BR-SR50-Z4 processing board by means of CB-ST50 cable which must have a maximum length of 150 metres.

PART NUMBER	DESCRIPTION	SENSOR SPACING	NO. OF SENSORS EACH STRING	COLOUR
LN20-SR50-250	Prewired sensor-string	2.5 m	20	BLACK

CONNECTION CABLE

PART NUMBER
CB-ST50



Tinned copper two-wire shielded cable for the connection of SN-SR50 sensors prewired in a string to the UA-SRC50 Analysis Unit. It is available in 25, 50 and 100 metres hanks in black colour.

TECHNICAL FEATURES

Please see CB-ST50 on page 90.

PART NUMBER	DESCRIPTION	LENGTH	COLOUR
CB-ST50-25	Connection cable	25 m	BLACK
CB-ST50-50	Connection cable	50 m	BLACK
CB-ST50-100	Connection cable	100 m	BLACK

SENSOR

PART NUMBER
SN-SR50



Piezodynamic sensor prewired in a sensor-string with customized length (less than 50 metres) and with 2m, 2.5m or 3m distance between the sensors.

TECHNICAL FEATURES

Please see SN-SR50 on page 87.

PART NUMBER	DESCRIPTION	SENSOR SPACING	MAX NO. OF SENSORS EACH STRING	COLOUR
SN-SR50-250	Sensor prewired in a sensor-string	2.5 m	20	BLACK

APPLICATION EXAMPLES

INSTALLATION OF A SERIR COMPACT 50 SENSOR-STRING

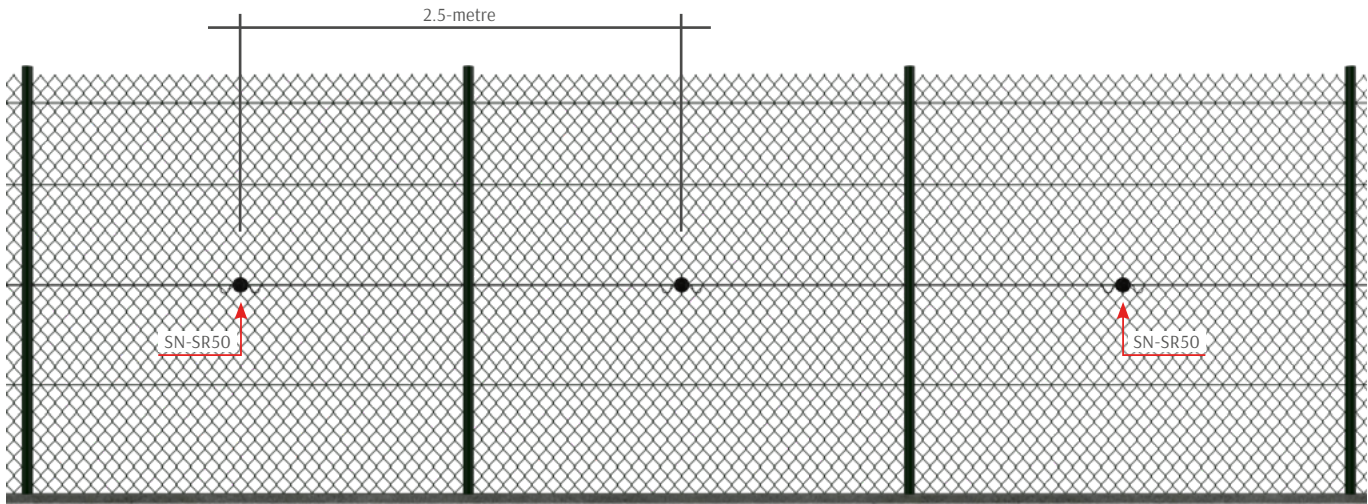

CONFIGURATION OF A SERIR COMPACT 50 ANALYSIS UNIT FOR THE PROTECTION OF A 100-METRE FENCE

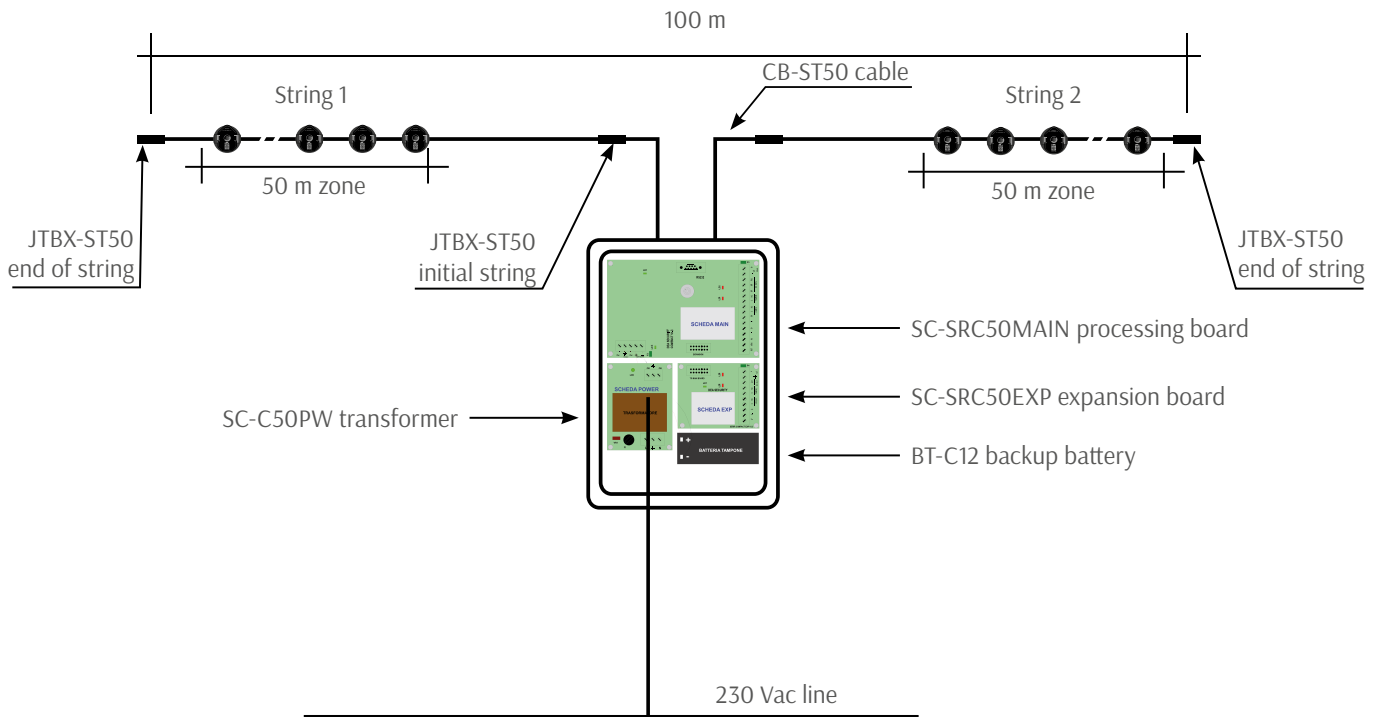

EXAMPLE OF PROTECTION OF A 50-METRE FENCE

The site is enclosed by a rolled fence with 2.5-metre distance from post to post and by a dual swinging gate.

- **FENCE PROTECTION:**
 - no. 1 MD-SRC50-250 Basic Module, corresponding to 1 alarm zone of 50 metres;
- **GATE PROTECTION:**
 - with third-party device to be connected to the control panel.
- **INTEGRATION WITH THE CONTROL PANEL:**
 - by means of dry contacts provided by the Analysis Unit.

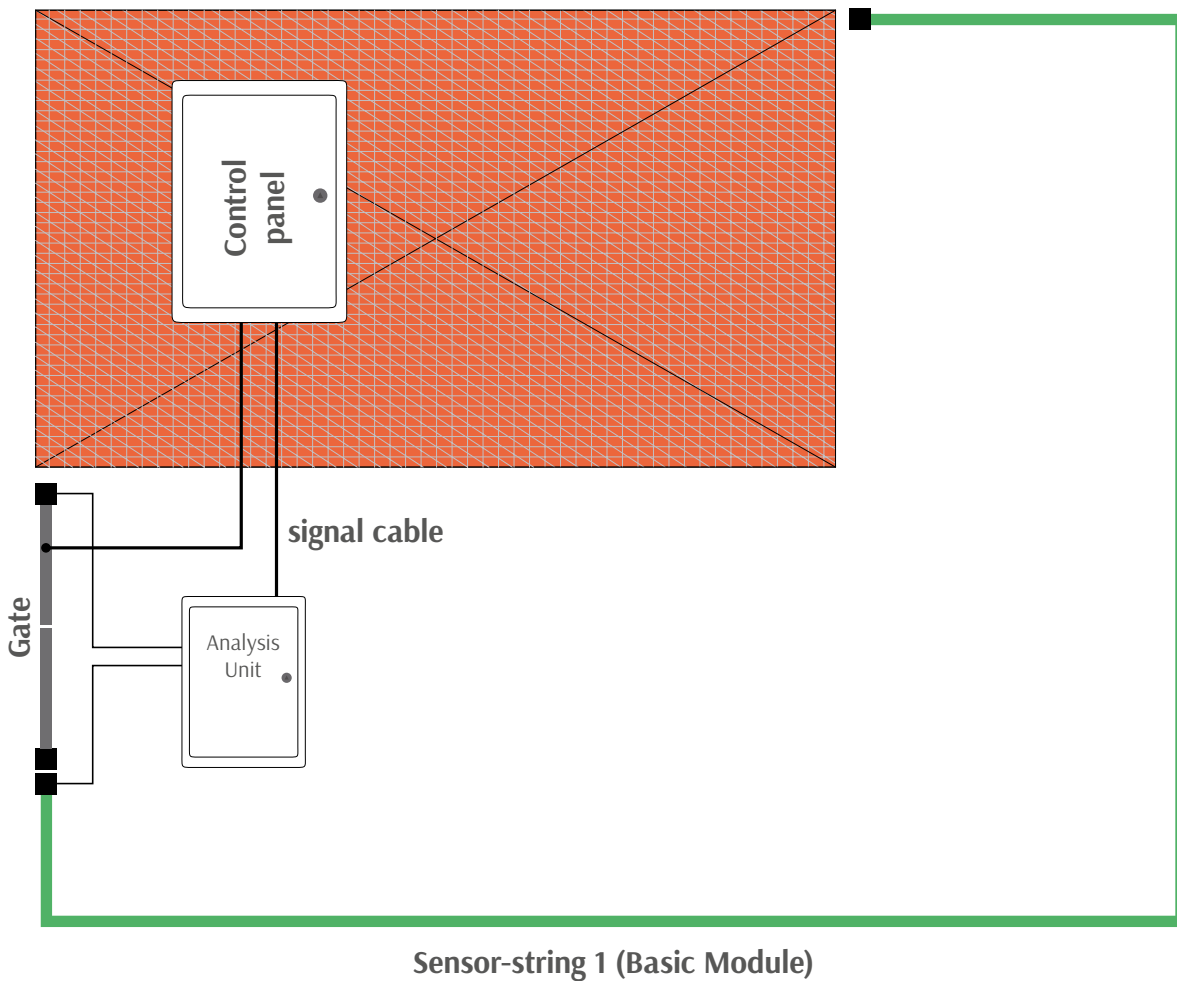

LIST OF PARTS TO MAKE A SYSTEM AS PER THE ABOVE EXAMPLE:

modules

Q.TY	PART NUMBER	DESCRIPTION
1	MD-SRC50-250	Basic Module with 2.5-metre spacing between the sensors

OUTDOOR SYSTEMS

TORSUS

PIEZOCERAMIC SYSTEMS FOR RIGID METAL FENCES

TORSUS is a line of perimeter intrusion detection systems dedicated to the protection of rigid metal fences. TORSUS employs sensors with a piezoceramic transducer which detect cut, climb and break-through attempts.

- **TORSUS 50**

It employs piezoceramic passive sensors supplied in prewired strings up to 50 metres long. The electronics is aboard special processing boards managing up to 200 metres of perimeter (for the four-zone version of the boards).

- **TORSUS COMPACT 50**

Compact version of TORSUS 50 system supplied in ready-to-use kits to cover 50 metres of perimeter. A special expansion kit allows you to cover up to 100 metres with a single Analysis Unit.

TORSUS 50

TORSUS 50

Prewired sensor-string, 50 metres long. One string can be composed of either 25 or 20 SN-TR50 sensors depending on the fence panel width to be protected: 2 metres in the first case and 2.5 metres in the second case.

TECHNICAL FEATURES

Please see SN-TR50 on page 116.



The LN-TR50 sensor-string must be connected to either BR-TR50-Z2 or BR-TR50-Z4 processing board by means of CB-ST50 cable which must have a maximum length of 50 metres.



Should you need sensor-strings with customized lengths (less than 50 metres), you have to order the needed number of SN-TR50 sensors referring to the part number table on page 116. These sensors are supplied prewired in a string.

TORSUS 50 sensor-string is available in the following versions:

PART NUMBER	DESCRIPTION	SENSOR SPACING	NO. OF SENSORS EACH STRING	COLOUR
LN25-TR50-200	Prewired sensor-string	2 m	25	BLACK
LN20-TR50-250	Prewired sensor-string	2.5 m	20	BLACK



Piezoceramic sensor prewired in a sensor-string with customized length (less than 50 metres) and with 2m or 2.5m spacing between the sensors.

COMPLIANCE

SENSOR (if connected to BR-TR50-Z2 or BR-TR50-Z4):

- **Directive 2014/30/EU (EMC)**
 - EN 50130-4:2011+A1:2014
 - EN 61000-6-3:2007+A1:2011
- **Directive 2011/65/EU (RoHS)**
 - EN 50581:2012
- **CEI 79-2 (2nd edition)**

CONNECTION CABLE: please see CB-ST50 on page 120.

TECHNICAL FEATURES

SENSOR:

- **Environmental class:** IV (designed in accordance with Directive EN 50130-5)
- **Dimensions:** 33 x 152 x 24 mm (W x H x D)
- **Material:** glass fibre reinforced ABS housing, sealed with epoxy and UV resistant
- **Colour:** black
- **Operating temperature:** -40 ÷ +80 °C
- **Relative humidity:** 0 – 100%
- **IP rating:** IP68
- **Coverage area:** up to 6.25 m² (2.5 x 2.5 m - max dimensions of the fence panel with sensors installed on each post)

CONNECTION CABLE: please see CB-ST50 on page 120.



The sensor-string composed of SN-TR50 sensors must be connected to either BR-TR50-Z2 or BR-TR50-Z4 processing board by means of CB-ST50 cable which must have a maximum length of 50 metres.

TORSUS 50 sensor is available in the following versions:

PART NUMBER	DESCRIPTION	SENSOR SPACING	MAX NO. OF SENSORS EACH STRING	COLOUR
SN-TR50-200	Sensor prewired in a sensor-string	2 m	25	BLACK
SN-TR50-250	Sensor prewired in a sensor-string	2.5 m	20	BLACK

SINGLE SENSOR

PART NUMBER
SN-TR50-S



SN-TR50 single sensor, prewired with 5 metres inlet and outlet cable.

TECHNICAL FEATURES

Please see SN-TR50 on page 116.



The SN-TR50-S sensor must be connected to BR-TR50-Z2 or BR-TR50-Z4 processing board by means of CB-ST50 cable which must have a maximum length of 50 metres.

PART NUMBER	DESCRIPTION	NOTE	COLOUR
SN-TR50-S	Prewired single sensor	5m inlet and outlet cable	BLACK

SINGLE SENSOR WITH TERMINATION

PART NUMBER
SN-TR50-ST



SN-TR50 single sensor, prewired with 5 metres inlet cable and with integrated termination.

TECHNICAL FEATURES

Please see SN-TR50 on page 116.



The SN-TR50-ST sensor must be connected to BR-TR50-Z2 or BR-TR50-Z4 processing board by means of CB-ST50 cable which must have a maximum length of 50 metres.

PART NUMBER	DESCRIPTION	NOTE	COLOUR
SN-TR50-ST	Prewired single sensor	5m inlet cable and integrated termination	BLACK

SENSOR-STRINGS WITH METAL TUBE

PART NUMBER
LN-TR50-GM

Prewired sensor-string 50 metres long, with cable protected by flexible metal tube. One string can be composed of 25 or 20 ST-TR50-GM sensors depending on the fence panel width which can be 2 or 2.5 metres respectively.

TECHNICAL FEATURES

Please see SN-TR50-GM on page 119.



The LN-TR50-GM sensor-string must be connected to either BR-TR50-Z2 or BR-TR50-Z4 processing board by means of CB-ST50 cable. The length of the cable connecting the sensor-string to the relevant processing board cannot be more than 150 metres.



Should you need sensor-strings with customized length (less than 50 metres), you have to order the needed number of SN-TR50-GM sensors referring to the part number table on page 119. These sensors are supplied prewired in a string.

TORSUS 50 sensor-string with cable protected by flexible metal tube is available **ON REQUEST**.

PART NUMBER	DESCRIPTION	SENSOR SPACING	NO. OF SENSORS EACH STRING	COLOUR
LN25-TR50-GM200	Prewired sensor-string with metal tube	2 m	25	BLACK
LN20-TR50-GM250	Prewired sensor-string with metal tube	2.5 m	20	BLACK



SN-TR50 sensor prewired in a sensor-string with connection cable protected by flexible metal tube for a higher physical and mechanical resistance.

COMPLIANCE

SENSOR (if connected to BR-TR50-Z2 or BR-TR50-Z4):

- **Directive 2014/30/EU (EMC)**
 - EN 50130-4:2011+A1:2014
 - EN 61000-6-3:2007+A1:2011
- **Directive 2011/65/EU (RoHS)**
 - EN 50581:2012
- **CEI 79-2 (2nd edition)**

CONNECTION CABLE: please see CB-ST50 on page 120.

TECHNICAL FEATURES

SENSOR:

- **Environmental class:** IV (designed in accordance with Directive EN 50130-5)
- **Dimensions:** 33 x 152 x 24 mm (W x H x D)
- **Material:** glass fibre reinforced ABS housing, sealed with epoxy and UV resistant
- **Colour:** black
- **Operating temperature:** -40 ÷ +80 °C
- **Relative humidity:** 0 – 100%
- **IP rating:** IP68
- **Coverage area:** up to 6.25 m² (2.5 x 2.5 m - max dimensions of the fence panel with sensors installed on each post)

CONNECTION CABLE: please see CB-ST50 on page 120.

JACKET:

- **Diameter:** 10 mm
- **Material:** galvanized steel with single seam and PVC vacuum covered esterna in PVC aspirato
- **Colour:** black



The sensor-string composed of SN-TR50-GM sensors must be connected to either BR-TR50-Z2 or BR-TR50-Z4 processing board by means of CB-ST50 cable which must have a maximum length of 50 metres.

TORSUS 50 sensor with cable protected with flexible metal tube is available **ON REQUEST**.

PART NUMBER	DESCRIPTION	SENSOR SPACING	MAX NO. OF SENSORS EACH STRING	COLOUR
SN-TR50-GM200	Sensor prewired in a string and with cable protected by flexible metal tube	2 m	25	BLACK
SN-TR50-GM250	Sensor prewired in a string and with cable protected by flexible metal tube	2.5 m	20	BLACK



Tinned copper two-wire shielded cable for the connection of LN-TR50 sensor-string, of SN-TR50 and SN-TR50-GM sensors prewired in a string and of SN-TR50-S and SN-TR50-ST single sensors to either BR-SR50-Z2 or BR-SR50-Z4 processing boards.

COMPLIANCE

- Directive 2006/95/CE
- CEI 20-11, CEI 20-14 p.q.a., CEI 20-35/1-2
- EN 50363, EN 60332-1-2
- IEC 60332-1
- UL 1581
- RoHS
- REACH

TECHNICAL FEATURES

- **Diameter:** 6.2 mm
- **Conductors:** 2 twisted tinned copper wires
- **Cross sectional area:** 0.25 mm² (24 AWG)
- **Operating temperature:**
 - -40 ÷ +80 °C (fixed installation)
 - -15 ÷ +80 °C (mobile installation)
- **Installation temperature:** -15 ÷ +50 °C
- **Insulation voltage:** 0.6/1 kV
- **Wire insulation material:** polyolefin
- **Shielding:**
 - tinned copper braid (coverage >90%)
 - Aluminium/Polyester foil screen (coverage >100%) with tinned copper drain wire with cross sectional area of sect. 0.25 mm² (24 AWG)
- **Double jacket:** special flame retardant PVC compound, quality TM2/RZ
- **Bending radius:** 15 times outer diameter
- **Use:** this cable can be installed in a group of cables with max operating voltage of U_o/U 0.6/1 kV
- **Colour:** black

SERIR 50/TORSUS 50 cable is available in hanks of 25, 50, 100, 200 metres and in reels of 500 metres.

PART NUMBER	DESCRIPTION	LENGTH	COLOUR
CB-ST50-25	Connection cable	25 m	BLACK
CB-ST50-50	Connection cable	50 m	BLACK
CB-ST50-100	Connection cable	100 m	BLACK
CB-ST50-200	Connection cable	200 m	BLACK
CB-ST50-500	Connection cable	500 m	BLACK



UV resistant polyamide case for junction and termination of TORSUS 50 sensor-strings.
Supplied with a printed circuit board to simplify the wiring procedures.

COMPLIANCE

IF CONNECTED TO LN-TR50 or LN-TR50-GM:

- **Directive 2014/30/EU (EMC)**
 - EN 50130-4:2011+A1:2014
 - EN 61000-6-3:2007+A1:2011
- **Directive 2011/65/EU (RoHS)**
 - EN 50581:2012

TECHNICAL FEATURES

- **Environmental class:** IV (designed in accordance with Directive EN 50130-5)
- **Dimensions:** 30 x 114 x 30 mm (W x H x D)
- **Gross weight:** 64 g
- **Net weight:** 60 g
- **Material:** glass fiber reinforced polyamide PA6-GF30
- **Colour:** black
- **Operating temperature:** -40 ÷ +80 °C
- **Relative humidity:** 0 - 100% (after sealing with RP-100 PUR cast resin)



To be wired with CB-ST50 or CV-ST50-P cable and to be sealed with RP-100 two-component PUR cast resin.

PART NUMBER	DESCRIPTION	COLOUR
JTBX-ST50	Junction/termination case	BLACK



Electronic processing board which manages two TORSUS 50 sensorstrings. It amplifies, digitizes and analyzes the signals coming from the sensor-strings, discriminating the typical signals of an intrusion from those generated by environmental nuisances. The board is equipped with Ethernet interface and IP Native support.

COMPLIANCE

IF CONNECTED TO LN-TR50 or LN-TR50-GM:

- **Directive 2014/30/EU (EMC)**
 - EN 50130-4:2011+A1:2014
 - IEC 61000-6-4:2018
- **Directive 2011/65/EU (RoHS)**
 - EN 50581:2012
- **CEI 79-2 (2nd edition)**

TECHNICAL FEATURES

- **Dimensions:** 178 x 90 x 40 mm (W x H x D)
- **Packaging dimensions:** 190 x 95 x 50 mm (W x H x D)
- **Gross weight:** 368 g
- **Net weight:** 240 g
- **Power supply:** 12 Vdc (+/- 25%)
- **Current:** 110 mA (max)
- **Operating temperature:** -25 ÷ +80 °C
- **Relative humidity:** <95% non condensing
- **Management capability (each line):** up to 25 TORSUS 50 detectors
- **Inputs:**
 - 2 analog for sensor-strings with resistor balancing
 - 2 digital opto-isolated, configurable by service software
- **NC relay outputs (positive security):**
 - 2 for alarm sensor-strings 1, 2
 - 2 for tampering sensor-strings 1, 2
 - 1 Low supply voltage/ Service Active/No Operating Software
- **OC outputs:** 2 for prealarm
- **Communication port:**
 - USB (PC link)
 - Ethernet (RJ45)
 - DEA NET bus
- **Calibration, settings and event management via software**
- **CPU:** 32 bit, 168 MHz
- **Digital memory:** more than 20.000 events
- **Service software licence included**

PART NUMBER	DESCRIPTION
BR-TR50-Z2	Dual-zone processing board



Electronic processing board which manages four TORSUS 50 sensorstrings. It amplifies, digitizes and analyzes the signals coming from the sensor-strings, discriminating the typical signals of an intrusion from those generated by environmental nuisances.

The board is equipped with Ethernet interface and IP Native support.

COMPLIANCE

IF CONNECTED TO LN-TR50 or LN-TR50-GM:

- **Directive 2014/30/EU (EMC)**
 - EN 50130-4:2011+A1:2014
 - IEC 61000-6-4:2018
- **Directive 2011/65/EU (RoHS)**
 - EN 50581:2012
- **CEI 79-2 (2nd edition)**

TECHNICAL FEATURES

- **Dimensions:** 178 x 135 x 40 mm (W x H x D)
- **Packaging dimensions:** 280 x 160 x 45 mm (W x H x D)
- **Gross weight:** 700 g
- **Net weight:** 370 g
- **Power supply:** 12 Vdc (+/- 25%)
- **Current:** 113 mA (max)
- **Operating temperature:** -25 ÷ +80 °C
- **Relative humidity:** <95% non condensing
- **Management capability (each line):** up to 25 TORSUS 50 detectors
- **Inputs:**
 - 4 analog for sensor-strings with resistor balancing
 - 4 digital opto-isolated programmable da software
- **NC relay outputs (positive security):**
 - 4 for alarm sensor-strings 1, 2, 3, 4
 - 4 for tampering sensor-strings 1, 2, 3, 4
 - 4 for prealarm
 - 1 Low supply voltage/ Service Active/No Operating Software
- **Communication port:**
 - USB (PC link)
 - Ethernet (RJ45)
 - DEA NET bus
- **Calibration, settings and event management via software**
- **CPU:** 32 bit, 168 MHz
- **Digital memory:** more than 20.000 events
- **Service software licence included**

PART NUMBER	DESCRIPTION
BR-TR50-Z4	Four-zone processing board

1-RELAY EXPANSION BOARD

PART NUMBER
SC-ER1

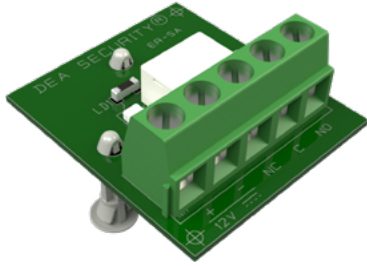

1-relay expansion board to convert OC outputs into C/NC/NO contacts.

COMPLIANCE

IF CONNECTED TO BOARDS WHICH PROVIDE FOR ITS USE:

- Directive 2014/30/EU (EMC)

TECHNICAL FEATURES

- **Dimensions:** 36 x 32 x 31 mm (W x H x D)
- **Gross weight:** 13 g
- **Power supply:** 12 Vdc (+/- 25%)
- **Current:** 12 mA
- **Operating temperature:** -25 ÷ +80 °C
- **Relative humidity:** <95% non condensing
- **Input:** 1 per OC signal
- **NC relay outputs (1 A):** C/NC/NO

TORSUS 50

PART NUMBER	DESCRIPTION
SC-ER1	1-relay expansion board (OC into C/NC/NO)

APPLICATION EXAMPLES

TORSUS 50

INSTALLATION OF A TORSUS 50 SENSOR-STRING

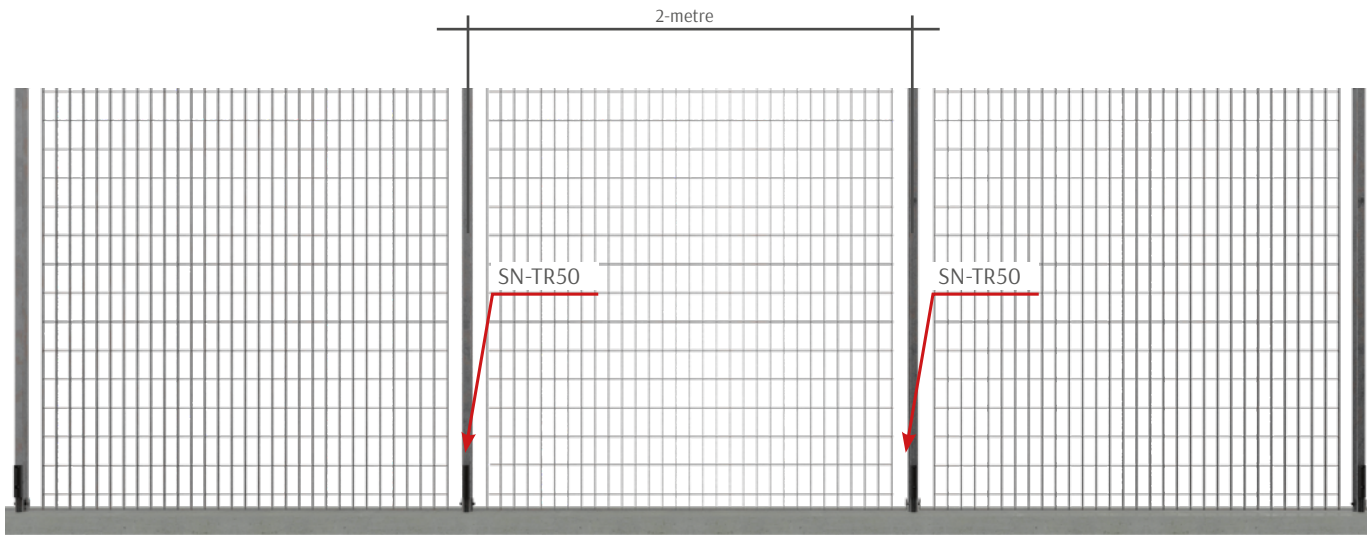

HOW TO INSTALL AN SN-TR50 SENSOR TO THE FENCE POST



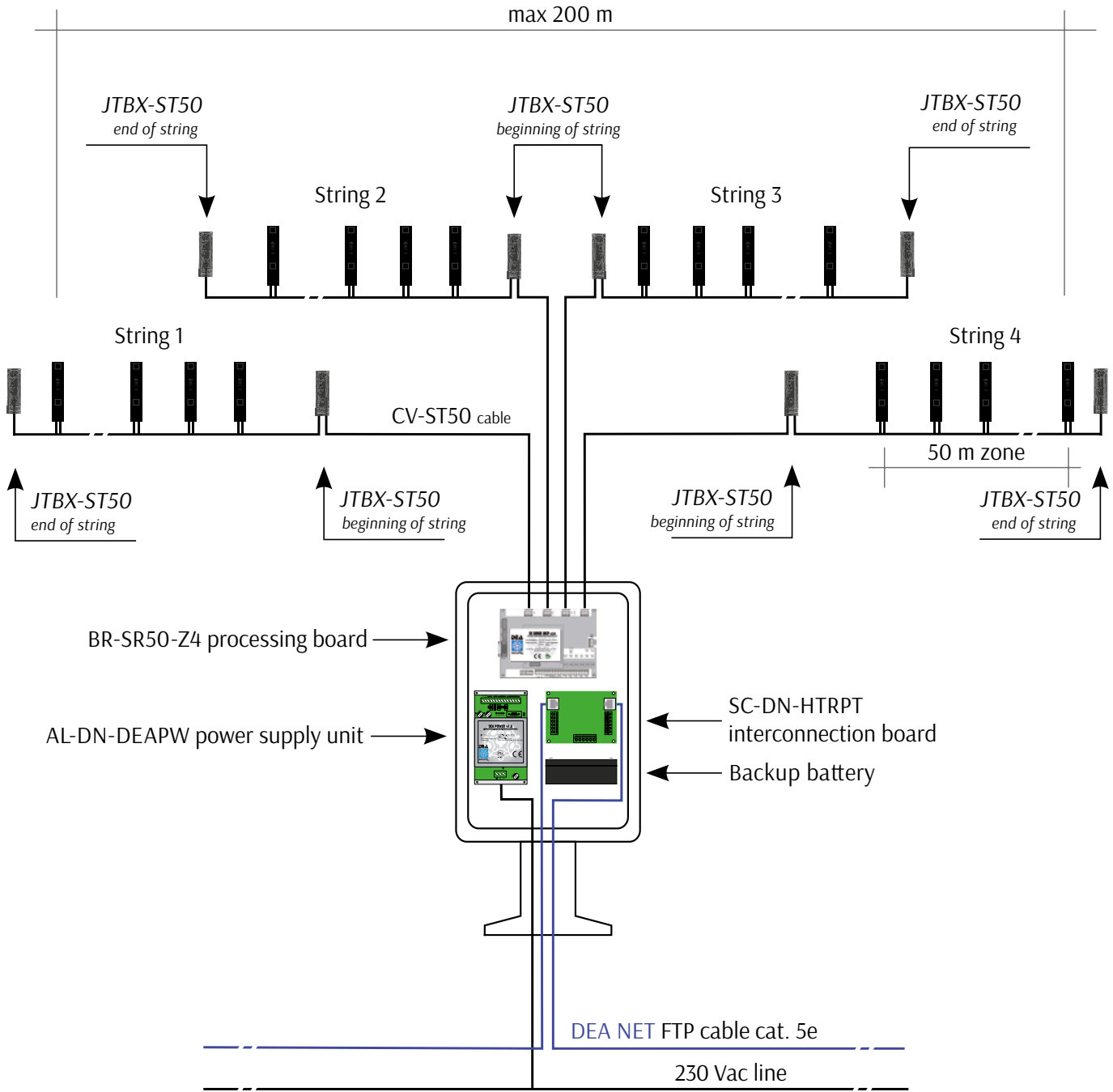

EXAMPLE OF PROTECTION FOR A 200-METRE RIGID METAL FENCE

The site to be protected is surrounded by a rigid metal fence with 2-metre panels and by a sliding gate.

• **FENCE PROTECTION:**

- no. 4 sensor-strings model LN25-TR50-200, corresponding to 4 alarm zones of 50 metres each;
- no. 1 field cabinet (Box1) containing the processing boards and the interface boards.

• **GATE PROTECTION:**

- no. 1 SC-DN-IO interface board to integrate the signals of magnetic contacts.

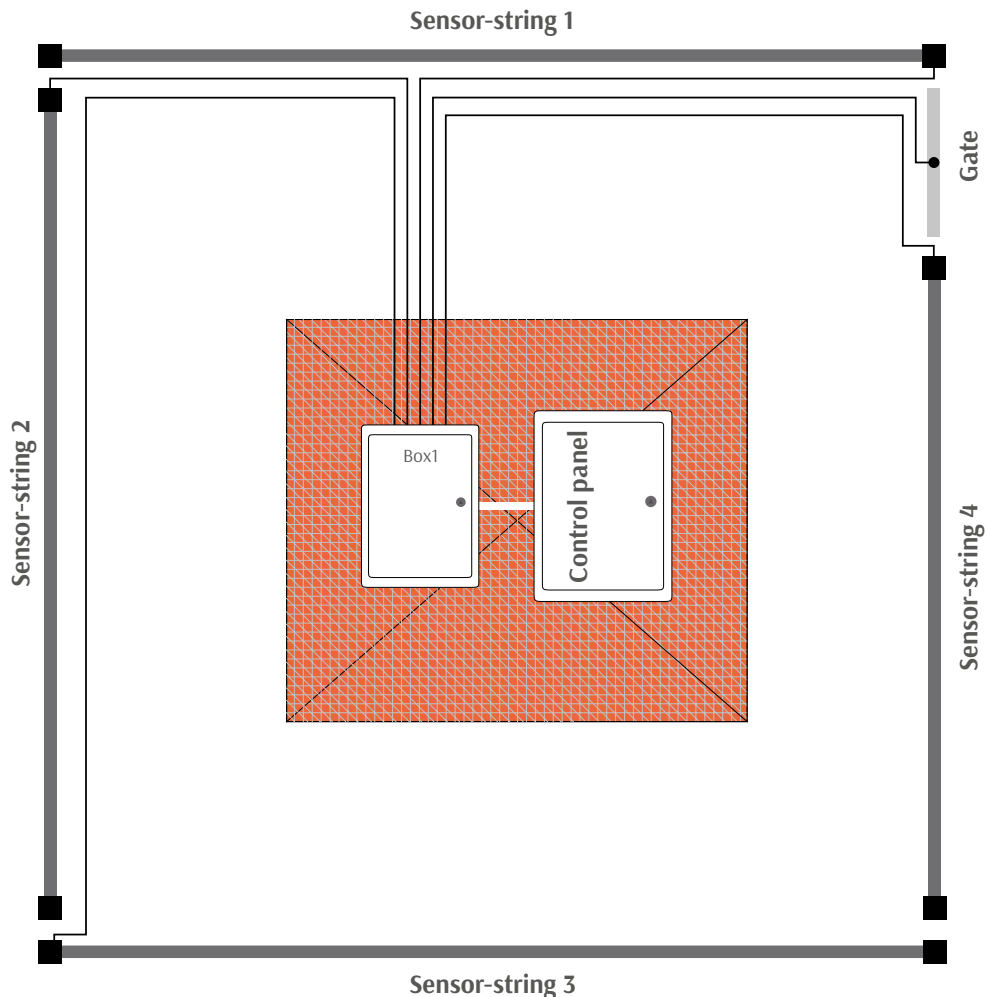

LIST OF PARTS TO MAKE A SYSTEM AS PER THE ABOVE EXAMPLE:

Sensor-strings, connection cable and wiring gateries

Q.TY	PART NUMBER	DESCRIPTION
4	LN25-TR50-200	Sensor-string for 2-metre fence panels
1	CB-ST50-200	Connection cable between the sensor-string and the processing board
8	FPA-150	UV resistant, self-locking tie-wraps
8	JTBX-ST50	Junction and termination case
4	RP-100	Two-component PUR cast resin to seal junction and termination cases

Cabinet Box1 and relevant processing boards

Q.TY	PART NUMBER	DESCRIPTION
1	AP-1C	Preassembled polyester cabinet
1	AL-20	Microprocessor stabilized linear power supply unit 2.5 A - 13.8 Vdc
1	BR-TR50-Z4	Four-zone processing board

TORSUS COMPACT 50

TORSUS COMPACT 50



Module for the protection of a rigid fence up to 50 metres long. It is composed of a prewired sensor-string of 20 sensors for the protection of fence panels with 2.5 metres width, a preassembled Analysis Unit, a 25-metre hank of cable and a wiring kit.

CONTENTS OF THE BASIC MODULE:

- **Analysis Unit UA-TRC50:**
 - BOX-C50 polyester cabinet
 - SC-TRC50MAIN processing board
 - SC-C50PW transformer
 - BT-C12 backup battery
- **Prewired sensor-string composed of 20 SN-TR50 sensors with 2.5-metre spacing, colour black**
- **CB-ST50 cable hank, 25 metres long, colour black**
- **Wiring kit KITCB-C50:**
 - 2 packs of FPA-150 tie-wraps (100 pcs each pack)
 - 1 pack of RP-100 two-component PUR cast resin (100g)
 - 2 JTBX-ST50 junction/termination cases

COMPLIANCE

- **Directive 2014/30/EU (EMC)**
 - › EN 50130-4:2011+A1:2014
 - › EN 61000-6-3:2007+A1:2011
- **Directive 2011/65/EU (RoHS)**
 - › EN 50581:2012
- **CEI 79-2 (2nd edition)**
- **IEC 62208, IEC 60695-2-10, IEC 60695-2-11, IEC 60695-11-5**

TECHNICAL FEATURES

- **Weight of the packed module:** approx. 14 Kg
- **For further technical data, please refer to the datasheets of the single devices.**



The sensor-string must be connected to UA-TRC50 Analysis Unit by means of CB-ST50 cable. The length of the cable connecting the sensor-string to the relevant Analysis Unit cannot be more than 150 metres.



To cover further 50 metres of perimeter, MD-TRC50EXP Expansion Module can be used.

PART NUMBER	DESCRIPTION	SENSOR SPACING	NO. OF SENSORS EACH STRING	COLOUR
MD-TRC50-250	Basic Module	2.5 m	20	BLACK



Module which allows to protect further 50 metres of perimeter, for 100 metres altogether.

It is composed of a prewired sensor-string of 20 sensors for the protection of fence panels with 2.5 metres width, a preassembled Analysis Unit, a 25-metre hank of cable and a wiring kit.

CONTENTS OF THE EXPANSION MODULE:

- SC-TRC50EXP expansion board
- Prewired sensor-string composed of 20 SN-TR50 sensors with 2.5-metre spacing, colour black
- CB-ST50 cable hank, 25 metres long, colour black
- **Wiring kit KITCB-C50:**
 - 2 packs of FPA-150 tie-wraps (100 pcs each pack)
 - 1 pack of RP-100 two-component PUR cast resin (100g)
 - 2 JTBX-ST50 junction/termination cases

COMPLIANCE

IF CONNECTED TO UA-TRC50:

- **Directive 2014/30/EU (EMC)**
 - › EN 50130-4:2011+A1:2014
 - › EN 61000-6-3:2007+A1:2011
- **Directive 2011/65/EU (RoHS)**
 - › EN 50581:2012
- **CEI 79-2 (2nd edition)**

TECHNICAL FEATURES

- **Weight of the packed module:** approx. 12 Kg
- **For further technical data, please refer to the datasheets of the single devices.**



The sensor-string must be connected to UA-TRC50 Analysis Unit by means of CB-ST50 cable. The length of the cable connecting the sensor-string to the relevant Analysis Unit cannot be more than 150 metres.



To one Basic Module can be connected one Expansion Module only.

PART NUMBER	DESCRIPTION	SENSOR SPACING	NO. OF SENSORS EACH STRING	COLOUR
MD-TRC50EXP-250	Expansion Module	2.5 m	20	BLACK

1-RELAY EXPANSION BOARD

PART NUMBER
SC-ER1

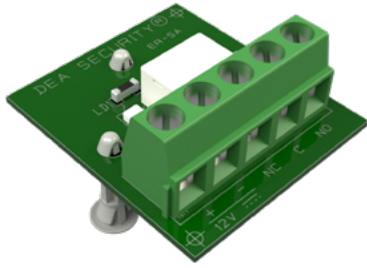

1-relay expansion board to convert OC outputs into C/NC/NO contacts.

COMPLIANCE

IF CONNECTED TO BOARDS WHICH PROVIDE FOR ITS USE:

- Directive 2014/30/EU (EMC)

TECHNICAL FEATURES

- **Dimensions:** 36 x 32 x 31 mm (W x H x D)
- **Gross weight:** 13 g
- **Power supply:** 12 Vdc (+/- 25%)
- **Current:** 12 mA
- **Operating temperature:** -25 ÷ +80 °C
- **Relative humidity:** <95% non condensing
- **Input:** 1 per OC signal
- **NC relay outputs (1 A):** C/NC/NO

PART NUMBER	DESCRIPTION
SC-ER1	1-relay expansion board (OC into C/NC/NO)

SPARE PARTS

Spare parts to integrate or replace the components contained in MD-TRC50 and MD-TRC50EXP modules.

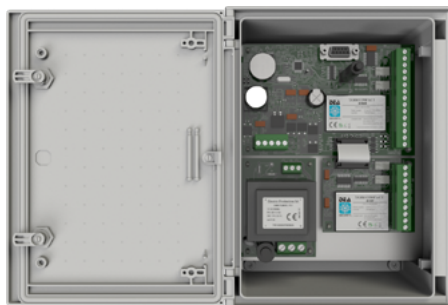

Polyester cabinet preassembled with a processing board (including tamper switch), a transformer and a backup battery.

UA-TRC50 CONTENTS:

- BOX-C50 polyester cabinet
- SC-TRC50MAIN processing board
- SC-C50PW transformer
- BT-C12 backup battery

COMPLIANCE

IF CONNECTED TO LN-TR50:

- **Directive 2014/30/EU (EMC)**
 - EN 50130-4:2011+A1:2014
 - EN 61000-6-3:2007+A1:2011
- **Directive 2011/65/EU (RoHS)**
 - EN 50581:2012
- CEI 79-2 (2nd edition)
- IEC 62208, IEC 60695-2-10, IEC 60695-2-11, IEC 60695-11-5

TECHNICAL FEATURES

ANALYSIS UNIT:

- **Environmental class:** IV (designed in accordance with Directive EN 50130-5)
- **Dimensions:** 200 x 255 x 135 mm (W x H x D)
- **Net weight:** approx. 2.9 Kg
- **Material:** polyester self-extinguishing housing, provided with ventilation openings
- **IP rating:** IP66 (IP54 with ventilation devices), IK10
- **Power supply:** 230 Vac \pm 10% 50 Hz
- **Max current consumption:** 50 mA
- **Backup battery:** 12 V, 1.2 Ah
- **Operating temperature:** -25 \div +70 °C
- **Relative humidity:** <95% non condensing

PROCESSING BOARD: please see SC-TRC50MAIN on page 135.

EXPANSION BOARD: please see SC-TRC50EXP on page 136.

PART NUMBER	DESCRIPTION
UA-TRC50	Analysis Unit

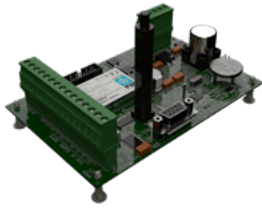

Microprocessor electronic board which manages one TORSUS 50 sensor-string. This board amplifies, digitizes and analyses the signals coming from the sensor-string, discriminating the typical signals of an intrusion from the ones generated by environmental nuisances.

COMPLIANCE

ASSEMBLED INSIDE UA-TRC50:

- **Directive 2014/30/EU (EMC)**
 - EN 50130-4:2011+A1:2014
 - EN 61000-6-3:2007+A1:2011
- **Directive 2011/65/EU (RoHS)**
 - EN 50581:2012
- **CEI 79-2 (2nd edition)**

TECHNICAL FEATURES

- **Dimensions:** 90 x 140 mm (B x H)
- **Power supply:** 15 Vac
- **Operating temperature:** -25 ÷ +80 °C
- **Relative humidity:** <95% non condensing
- **Management capability:** up to 25 TORSUS 50 sensors
- **Analog inputs:** 1 sensor-string with resistor balancing; max 25 sensors
- **Auxiliary inputs:**
 - reset
 - ARM (event storage)
 - anti-opening tamper (cabinet)
- **NC relay outputs (1 A):**
 - intrusion alarm
 - tamper
- **OC outputs (negative):**
 - prealarm
 - mains loss (230 Vac)
 - battery presence
- **Communication port:**
 - expansion board
 - RS-232 (PC link)
- **Digital memory:** more than 20.000 events
- **Service software licence included**

PART NUMBER	DESCRIPTION
SC-TRC50MAIN	Processing board

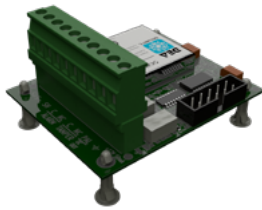

Electronic board which manages a second TORSUS 50 sensor-string to protect further 50 metres of perimeter. It must be mounted inside UA-TRC50 Analysis Unit and connected to the processing board.

COMPLIANCE

ASSEMBLED INSIDE UA-TRC50:

- **Directive 2014/30/EU (EMC)**
 - EN 50130-4:2011+A1:2014
 - EN 61000-6-3:2007+A1:2011
- **Directive 2011/65/EU (RoHS)**
 - EN 50581:2012
- **CEI 79-2 (2nd edition)**

TECHNICAL FEATURES

- **Dimensions:** 60 x 75 mm (B x H)
- **Power supply:** 12 Vdc (by flat cable from the processing board)
- **Operating temperature:** -25 ÷ +80 °C
- **Relative humidity:** <95% non condensing
- **Management capability:** up to 25 TORSUS 50 sensors
- **Analog inputs:** 1 sensor-string with resistor balancing; max 25 sensors
- **Power outputs:** AUX → 12 Vdc → 50 mA protected by reset fuse F4
- **NC relay outputs (1 A):**
 - intrusion alarm
 - tamper
- **OC outputs (negative):**
 - prealarm



The expansion board cannot work by itself but must be connected to the processing board present inside the Analysis Unit by means of the flat cable provided with it.

PART NUMBER	DESCRIPTION
SC-TRC50EXP	Expansion board

TRANSFORMER

PART NUMBER
SC-C50PW



Current transformer inside the Analysis Unit.

COMPLIANCE

ASSEMBLED INSIDE UA-TRC50:

- **Directive 2014/30/EU (EMC)**
 - EN 50130-4:2011+A1:2014
 - EN 61000-6-3:2007+A1:2011

TECHNICAL FEATURES

- **Dimensions:** 60 x 80 mm (B x H)
- **Power supply:** 230 Vac 50/60 Hz
- **Nominal power:** 10 VA
- **Operating temperature:** -25 ÷ +80 °C
- **Relative humidity:** <95% non condensing
- **Nominal input voltage:** Line, Neutral, Earth protected by fuse
- **Output:** 15 Vac

PART NUMBER	DESCRIPTION
SC-C50PW	Transformer

WIRING KIT

PART NUMBER
KITCB-C50



Kit for the sensor-string wiring. Includes two 100-piece packs of FPA-150 tie-wraps for tying the cable to the fence; two JTBX-ST50 cases for sensor-string junction/termination; one pack of RP-100 two-component PUR cast resin (100g) to seal JTBX-ST50 cases.

TECHNICAL FEATURES

Please see JTBX-ST50 on page 121, FPA-150 e RP-100 on page 205.

PART NUMBER	DESCRIPTION
KITCB-C50	Wiring kit

SENSOR-STRINGS

PART NUMBER
LN-TR50

Prewired sensor-string with standard length of 50 metres, composed of 25 SN-TR50 sensors for the protection of fence panels with 2,5 span.

TECHNICAL FEATURES

Please see SN-TR50 on page 116.



The LN-TR50 sensor-string must be connected to either BR-TR50-Z2 or BR-TR50-Z4 processing board by means of CB-ST50 cable which must have a maximum length of 50 metres.

PART NUMBER	DESCRIPTION	SENSOR SPACING	NO. OF SENSORS EACH STRING	COLOUR
LN20-TR50-250	Prewired sensor-string	2.5 m	20	BLACK

CONNECTION CABLE

PART NUMBER
CB-ST50



Tinned copper two-wire shielded cable for the connection of SN-TR50 sensors prewired in a string to the UA-TRC50 Analysis Unit. It is available in 25, 50 and 100 metres hanks in grey or green colour.

TECHNICAL FEATURES

Please see CB-ST50 on page 120.

PART NUMBER	DESCRIPTION	LENGTH	COLOUR
CB-ST50-25	Connection cable	25 m	BLACK
CB-ST50-50	Connection cable	50 m	BLACK
CB-ST50-100	Connection cable	100 m	BLACK

SENSOR

PART NUMBER
SN-TR50



Piezodynamic sensor prewired in a sensor-string with customized length (less than 50 metres) and with 2m, 2.5m or 3m distance between the sensors.



TECHNICAL FEATURES

Please see SN-TR50 on page 116.

PART NUMBER	DESCRIPTION	SENSOR SPACING	MAX NO. OF SENSORS EACH STRING	COLOUR
SN-TR50-250	Sensor prewired in a sensor-string	2.5 m	20	BLACK

APPLICATION EXAMPLES

INSTALLATION OF A TORSUS COMPACT 50 SENSOR-STRING

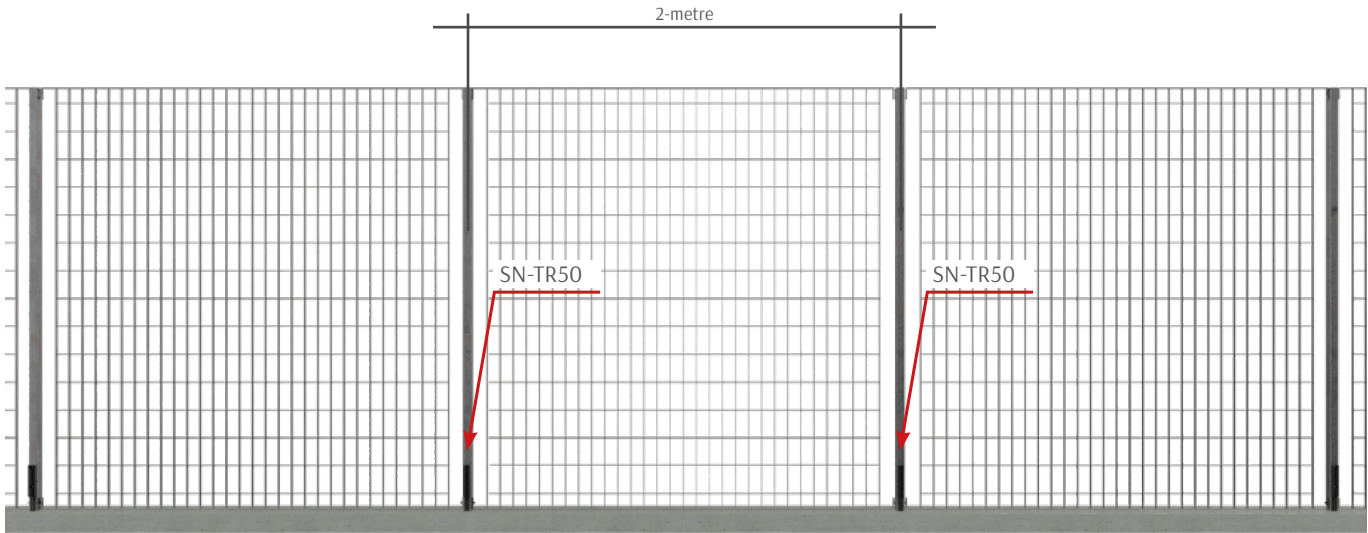

CONFIGURATION OF A TORSUS COMPACT 50 ANALYSIS UNIT FOR THE PROTECTION OF 100 METRES

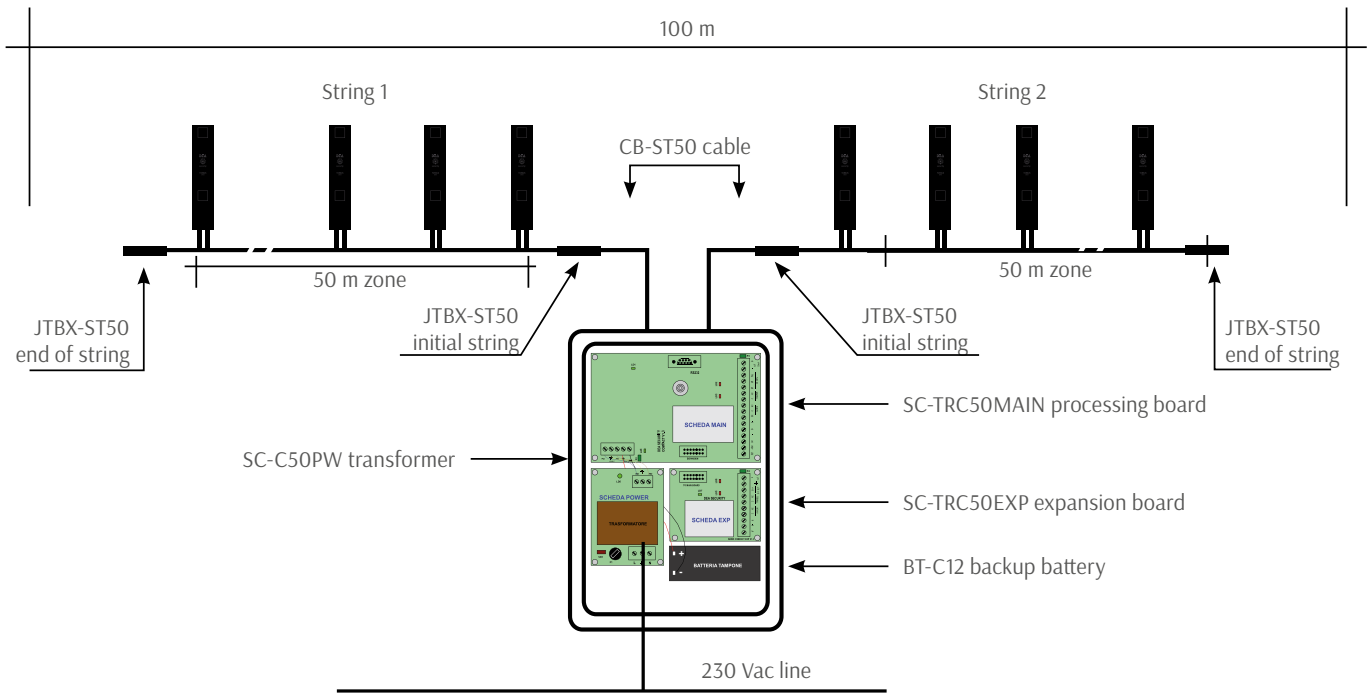

EXAMPLE OF PROTECTION FOR A 50-METRE RIGID FENCE

The site is enclosed by a rolled fence with 2.5-metre distance from post to post and by a dual swinging gate.

- **FENCE PROTECTION:**
 - no. 1 MD-TRC50-250 Basic Module, corresponding to 1 alarm zone of 50 metres;
- **GATE PROTECTION:**
 - with third-party device to be connected to the control panel.
- **INTEGRATION WITH THE CONTROL PANEL:**
 - by means of dry contacts provided by the Analysis Unit.

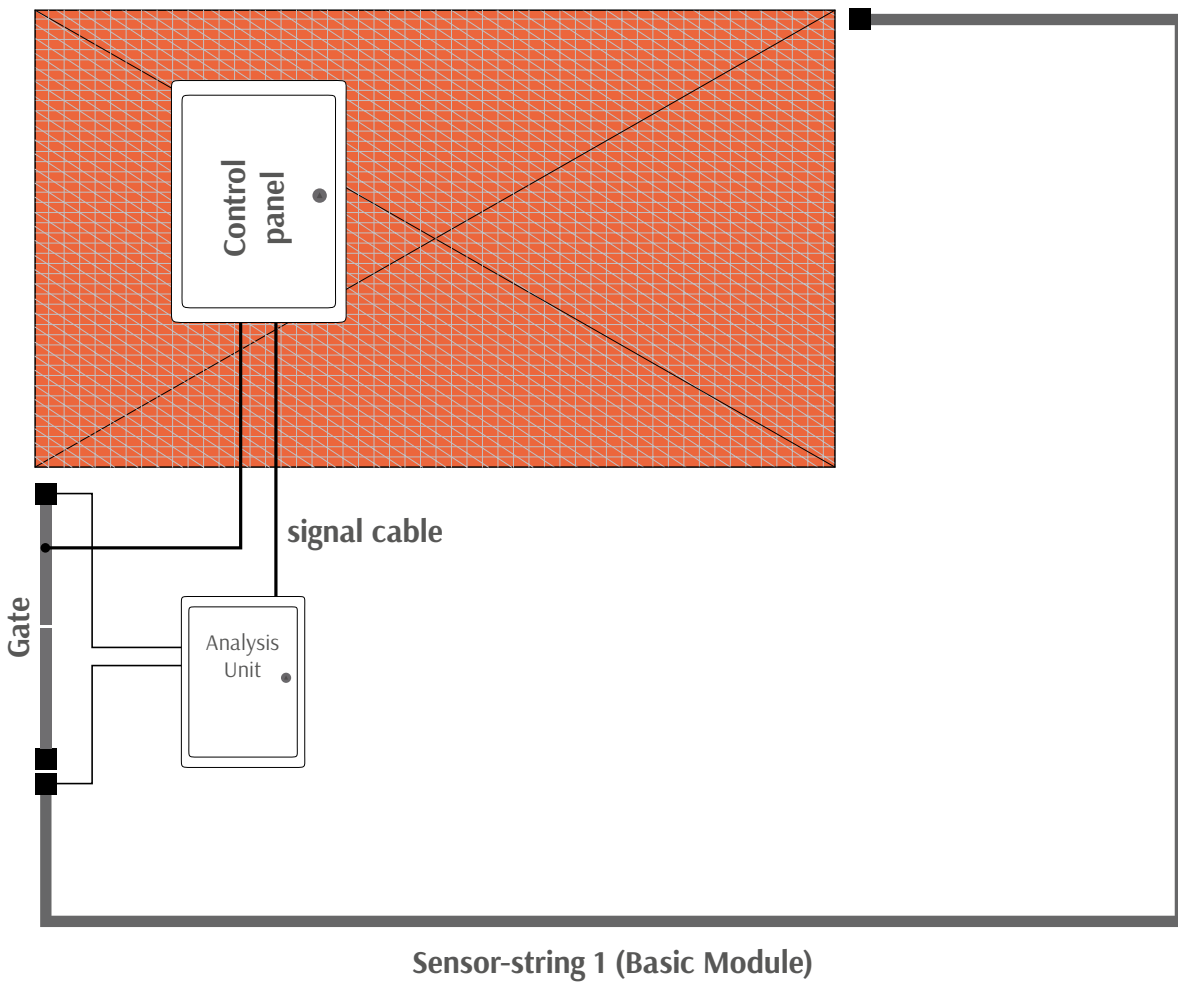

LIST OF PARTS TO MAKE A SYSTEM AS PER THE ABOVE EXAMPLE:

modules

Q.TY	PART NUMBER	DESCRIPTION
1	MD-TRC50-250	Basic Module with 2.5-metre spacing between the sensors

OUTDOOR SYSTEMS

SISMA CP 50

BURIED GEOSEISMIC SYSTEM

SISMA CP 50 is a buried intrusion detection system creating an invisible and unidentifiable detection band around the site to be protected. It employs passive geoseismic sensors supplied in strings up to 50 metres long.



Prewired sensor-string up to 50 metres long.
One string can be composed of 12, 34 or 56 SN-SMCP50 sensors to cover 10, 30 or 50 metres respectively.

TECHNICAL FEATURES

Please see SN-SMCP50 on page 145.



The LN-SMCP50 sensor-string must be connected to BR-SMCP50-Z1 or BR-SMCP50-Z2 processing board by means of CV-SMCP50 cable. The length of the cable connecting the sensor-string to the relevant processing board cannot be more than 150 metres.



The sensors must be laid at about 60 cm depth and must be placed every 90 cm.



Should you need sensor-strings with customized lengths, you can either join two or more standard sensor-strings by means of JBX-SMCP50 intermediate junction case or order the desired quantity of SN-SMCP50 sensors referring to the table on page 145. The resulting sensor-string must be less than 50 metres.

SISMA CP 50 sensor-string is available in the following versions:

PART NUMBER	DESCRIPTION	NO. OF SENSORS EACH STRING	LENGTH
LN12-SMCP50	Sensor-string	12	10 m
LN34-SMCP50	Sensor-string	34	30 m
LN56-SMCP50	Sensor-string	56	50 m



Geoseismic sensor prewired in a sensor-string with customized length (less than 50 metres).

COMPLIANCE

SENSOR (if connected to BR-SMCP50-Z1 or BR-SMCP50-Z2):

- **Directive 2014/30/EU (EMC)**
 - EN 50130-4:2011+A1:2014
 - EN 61000-6-3:2007+A1:2011
- **Directive 2011/65/EU (RoHS)**
 - EN 50581:2012
- **CEI 79-2 (2nd edition)**

CONNECTION CABLE: please see CV-SMCP50 on page 146.

TECHNICAL FEATURES

SENSOR:

- **Environmental class:** IV (designed in accordance with Directive EN 50130-5)
- **Dimensions:** 95 x 185 mm (Ø x H)
- **Material:** ABS body, sealed with epoxy
- **Colour:** black
- **Operating temperature:** -40 ÷ +80 °C
- **Relative humidity:** 0 – 100%

CONNECTION CABLE: please see CV-SMCP50 on page 146.



The sensor-string composed of SN-SMCP50 sensors must be connected to BR-SMCP50-Z1 or BR-SMCP50-Z2 processing boards by means of CV-SMCP50 cable. The length of the cable connecting the sensor-string to the relevant processing board cannot be more than 150 metres.



The sensors are supplied prewired in a string 50m long maximum.



The sensors must be laid at about 60 cm depth and must be placed every 90 cm.

PART NUMBER	DESCRIPTION
SN-SMCP50	Sensor prewired in a string



Tinned copper six-wire shielded cable with rodent-proof armour. It is used to connect LN-SMCP50 sensor-string and SN-SMCP50 sensor prewired in a string to BR-SMCP50-Z1 or BR-SMCP50-Z2 processing board.

COMPLIANCE

- Directive 2006/95/CE
- CEI 20-11, CEI 20-14 p.q.a., CEI 20-35/1-2
- EN 50363, EN 60332-1-2
- IEC 60332-1
- UL 1581
- RoHS
- REACH

TECHNICAL FEATURES

- **Diameter:** 10.5 mm
- **Conductors:** 6 tinned copper wires, twisted pairs
- **Cross sectional area:** 0.25 mm² (24 AWG)
- **Operating temperature:** -40 ÷ +80 °C (fixed installation)
- **Installation temperature:** -15 ÷ +50 °C
- **Insulation voltage:** 0.6/1 kV
- **Wire insulation material:** polyolefin
- **Shielding:**
 - tinned copper braid (coverage >70%)
 - Aluminium/Polyester foil screen (coverage >100%) with tinned copper drain wire with cross sectional area of sect. 0.25 mm² (24 AWG)
- **Armour:** rodent-proof galvanized iron braid armour (coverage nominal >80%)
- **Jacket:** PVC-based, non-flame propagating and oil resistant
- **Inner jacket:** polyethylene
- **Bending radius:** 15 times outer diameter
- **Use:** this cable can be installed in a group of cables with max operating voltage of U_o/U 0.6/1 kV
- **Colour:** grey

SISMA CP 50 cable is available in hanks of 50 or 100 metres and in reels of 500 metres.

PART NUMBER	DESCRIPTION	LENGTH	COLOUR
CV-SMCP50-A50	Connection cable	50 m	GREY
CV-SMCP50-A100	Connection cable	100 m	GREY
CV-SMCP50-A500	Connection cable	500 m	GREY



Thermocontrolled polyamide case to make initial string junctions for SISMA CP 50 system. It includes a printed circuit to simplify the wiring procedures.

COMPLIANCE

IF CONNECTED TO LN-SMCP50:

- **Directive 2014/30/EU (EMC)**
 - EN 50130-4:2011+A1:2014
 - EN 61000-6-3:2007+A1:2011
- **Directive 2011/65/EU (RoHS)**
 - EN 50581:2012
- **CEI 79-2 (2nd edition)**

TECHNICAL FEATURES

- **Environmental class:** IV (designed in accordance with Directive EN 50130-5)
- **Dimensions:**
 - **case:** 52 x 37 x 133 mm (major axis x minor axis x H)
 - **pile shoe:** 77 x 65 x 300 mm (major axis x minor axis x H)
- **Package gross weight:** 250 g
- **Material:**
 - **case:** glass fiber reinforced polyamide
 - **pile shoe:** ABS
- **Colour:** black
- **Operating temperature:** -40 ÷ +80 °C
- **Relative humidity:** 0 – 100% (after sealing with RP-100 PUR cast resin)



To be used with the CV-SMCP50 connection cable and to be sealed with the RP-100 two-component PUR cast resin.



For intermediate string junctions, the JBX-SMCP50 case must be used.

PART NUMBER	DESCRIPTION	COLOUR
JBX-SMCP50-ILT	Initial string junction case	BLACK

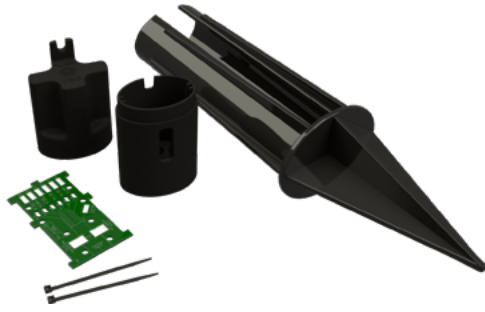

Polyamide case to join parts of the same SISMA CP 50 sensor-string. It includes a printed circuit to simplify the wiring procedures.

COMPLIANCE

IF CONNECTED TO LN-SMCP50:

- **Directive 2014/30/EU (EMC)**
 - EN 50130-4:2011+A1:2014
 - EN 61000-6-3:2007+A1:2011
- **Directive 2011/65/EU (RoHS)**
 - EN 50581:2012
- **CEI 79-2 (2nd edition)**

TECHNICAL FEATURES

- **Environmental class:** IV (designed in accordance with Directive EN 50130-5)
- **Dimensions:**
 - **case:** 52 x 37 x 133 mm (major axis x minor axis x H)
 - **pile shoe:** 77 x 65 x 300 mm (major axis x minor axis x H)
- **Package gross weight:** 250 g
- **Material:**
 - **case:** glass fiber reinforced polyamide
 - **pile shoe:** ABS
- **Colour:** black
- **Operating temperature:** -40 ÷ +80 °C
- **Relative humidity:** 0 – 100% (after sealing with RP-100 PUR cast resin)



To be used with the CV-SMCP50 connection cable and to be sealed with the RP-100 two-component PUR cast resin.



It must be used when you need to join two standard sensor-strings or pieces of the same sensor-string previously cut.



For initial string junctions, the JBX-SMCP50-ILT junction case must be used.

PART NUMBER	DESCRIPTION	COLOUR
JBX-SMCP50	Intermediate junction case	BLACK

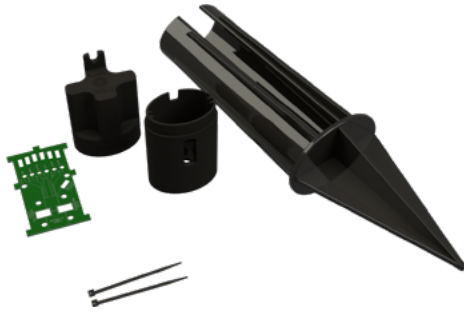

Termination case for SISMA CP 50 sensor-string. Supplied with a printed circuit board to simplify the wiring procedures.

COMPLIANCE

IF CONNECTED TO LN-SMCP50:

- **Directive 2014/30/EU (EMC)**
 - EN 50130-4:2011+A1:2014
 - EN 61000-6-3:2007+A1:2011
- **Directive 2011/65/EU (RoHS)**
 - EN 50581:2012
- **CEI 79-2 (2nd edition)**

TECHNICAL FEATURES

- **Environmental class:** IV (designed in accordance with Directive EN 50130-5)
- **Dimensions:**
 - **case:** 52 x 37 x 133 mm (major axis x minor axis x H)
 - **pile shoe:** 77 x 65 x 300 mm (major axis x minor axis x H)
- **Package gross weight:** 250 g
- **Material:**
 - **case:** glass fiber reinforced polyamide
 - **pile shoe:** ABS
- **Colour:** black
- **Operating temperature:** -40 ÷ +80 °C
- **Relative humidity:** 0 – 100% (after sealing with RP-100 PUR cast resin)



To be used with the CV-SMCP50 connection cable and to be sealed with the RP-100 two-component PUR cast resin.

PART NUMBER	DESCRIPTION	COLOUR
TBX-SMCP50	Termination case	BLACK



Electronic processing board which manages one SISMA CP 50 sensorstring. It amplifies, digitizes and analyzes the signals coming from the sensors, discriminating the typical signals of an intrusion from those generated by environmental nuisances. The board is equipped with Ethernet interface and IP Native support.

COMPLIANCE

IF CONNECTED TO LN-SMCP50:

- **Directive 2014/30/EU (EMC)**
 - EN 50130-4:2011+A1:2014
 - IEC 61000-6-4:2018
- **Directive 2011/65/EU (RoHS)**
 - EN 50581:2012
- **CEI 79-2 (2nd edition)**

TECHNICAL FEATURES

- **Dimensions:** 178 x 90 x 40 mm (W x H x D)
- **Packaging dimensions:** 190 x 95 x 50 mm (W x H x D)
- **Gross weight:** 368 g
- **Net weight:** 240 g
- **Power supply:** 12 Vdc (+/- 25%)
- **Current:** 110 mA (max)
- **Operating temperature:** -25 ÷ +80 °C
- **Relative humidity:** <95% non condensing
- **Management capability (each line):** up to 56 SISMA CP 50 detectors
- **Inputs:**
 - 2 digital opto-isolated, configurable by service software
- **NC relay outputs (positive security):**
 - 1 for alarm sensor-strings
 - 1 for tampering sensor-strings
 - 1 Low supply voltage/ Service Active/No Operating Software
- **Communication port:**
 - USB (PC link)
 - Ethernet (RJ45)
 - DEA NET bus
- **Calibration, settings and event management via software**
- **CPU:** 32 bit, 168 MHz
- **Digital memory:** more than 20.000 events
- **Service software licence included**

PART NUMBER	DESCRIPTION
BR-SMCP50-Z1	Single-zone processing board



Electronic processing board which manages two SISMA CP 50 sensor-strings. It amplifies, digitizes and analyses the signals coming from the sensors, discriminating the typical signals of an intrusion event from the ones generated by environmental nuisances. The board is equipped with Ethernet interface and IP native support.

COMPLIANCE

IF CONNECTED TO LN-SMCP50:

- **Directive 2014/30/EU (EMC)**
 - EN 50130-4:2011
 - EN 61000-6-3:2007+A1:2011
- **Directive 2011/65/EU (RoHS)**
 - EN 50581:2012
- **CEI 79-2 (2nd edition)**

TECHNICAL FEATURES

- **Dimensions:** 178 x 135 x 40 mm (W x H x D)
- **Packaging dimensions:** 190 x 95 x 50 mm (W x H x D)
- **Gross weight:** 700 g
- **Net weight:** 370 g
- **Power supply:** 12 Vdc (+/- 25%)
- **Current:** 130 mA (max)
- **Operating temperature:** -25 ÷ +80 °C
- **Relative humidity:** <95% non condensing
- **Management capability (each line):** up to 56 SISMA CP 50 detectors
- **Inputs:**
 - 2 analog for sensor-strings
 - 2 digital opto-isolated, configurable by service software
- **NC relay outputs (positive security):**
 - 2 for alarm sensor-strings 1, 2
 - 2 for tampering sensor-strings 1, 2
 - 2 for prealarm
 - 1 Low supply voltage/ Service Active/No Operating Software
- **Communication port:**
 - USB (PC link)
 - Ethernet (RJ45)
 - DEA NET bus
- **Calibration, settings and event management via software**
- **CPU:** 32 bit, 168 MHz
- **Digital memory:** more than 20.000 events
- **Service software licence included**

PART NUMBER	DESCRIPTION
BR-SMCP50-Z2	Dual-zone processing board

1-RELAY EXPANSION BOARD

PART NUMBER
SC-ER1

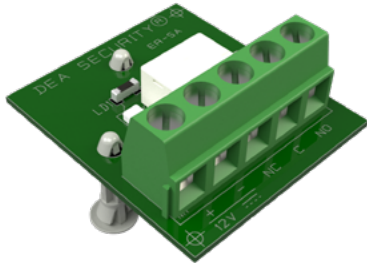

1-relay expansion board to convert OC outputs into C/NC/NO contacts.

COMPLIANCE

IF CONNECTED TO BOARDS WHICH PROVIDE FOR ITS USE:

- Directive 2014/30/EU (EMC)

TECHNICAL FEATURES

- **Dimensions:** 36 x 32 x 31 mm (W x H x D)
- **Gross weight:** 13 g
- **Power supply:** 12 Vdc (+/- 25%)
- **Current:** 12 mA
- **Operating temperature:** -25 ÷ +80 °C
- **Relative humidity:** <95% non condensing
- **Input:** 1 per OC signal
- **NC relay outputs (1 A):** C/NC/NO

SIGMA CP 50

PART NUMBER	DESCRIPTION
SC-ER1	1-relay expansion board (OC into C/NC/NO)

APPLICATION EXAMPLES



TYPICAL CONFIGURATION OF A SISMA CP 50 FIELD CABINET (2 ZONES)

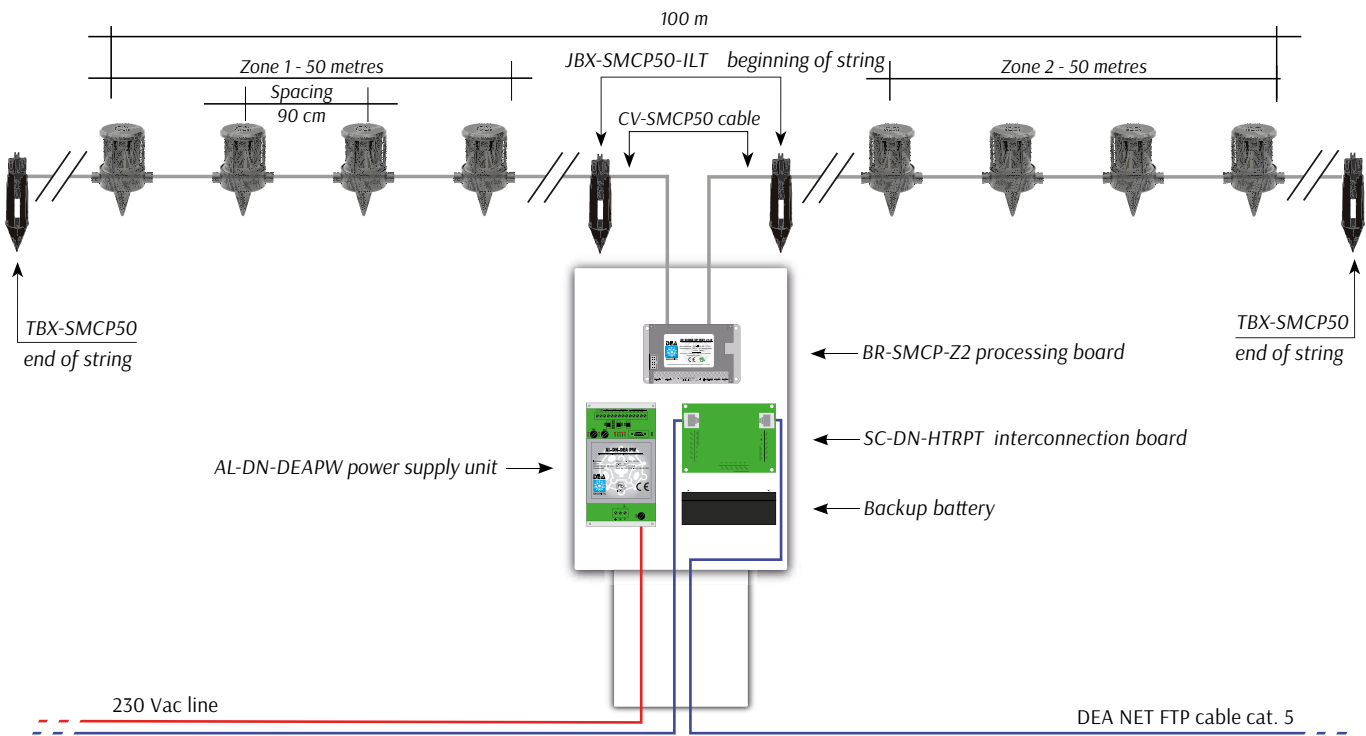

EXAMPLE OF PROTECTION FOR 200-METRE BURIED SYSTEM

• **UNDERGROUND PROTECTION:**

- no. 4 sensor-strings model LN56-SMCP50, corresponding to 4 alarm zones of 50 metres each;
- no. 1 field cabinet (Box1) containing the processing boards and the interface boards.

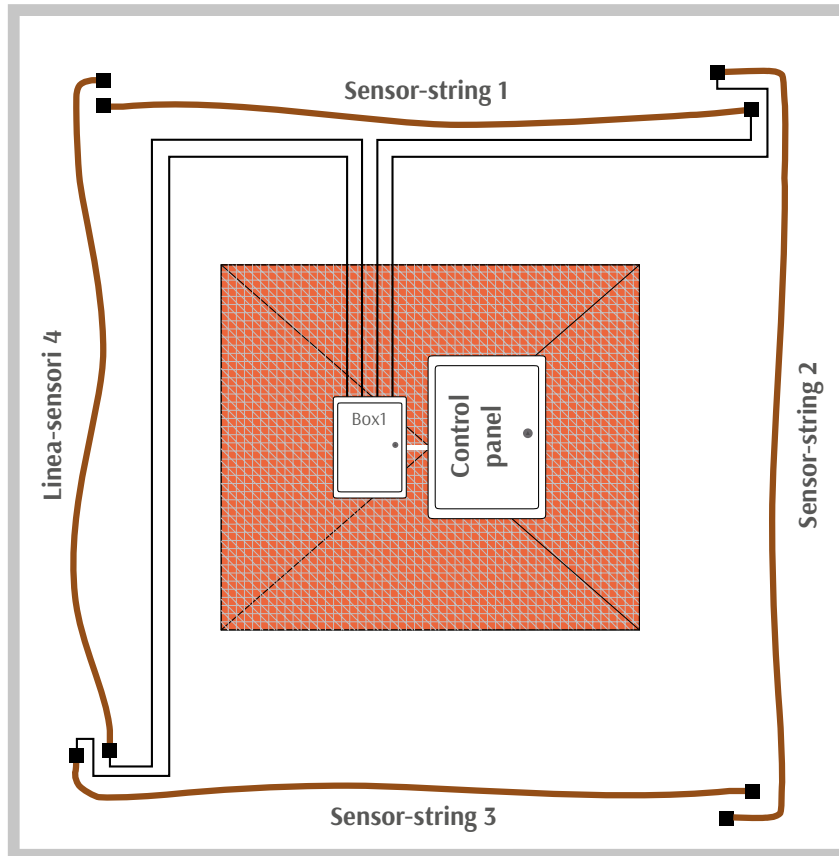

LIST OF PARTS TO MAKE A SYSTEM AS PER THE ABOVE EXAMPLE:

Sensor-strings, connection cable and wiring gateries

Q.TY	PART NUMBER	DESCRIPTION
4	LN56-SMCP50	Sensor-string prewired with 56 sensors (50 metres)
1	CV-SMCP50-A100	Connection cable between the sensor-string and the processing board
4	JBX-SMCP50-ILT	Initial string junction case
4	TBX-SMCP50	Termination case
8	RP-100	Two-component PUR cast resin to seal junction and termination cases

Cabinet Box1 e relative schede elettroniche

Q.TY	PART NUMBER	DESCRIPTION
1	AP-1C	Preassembled polyester cabinet
1	AL-20	Microprocessor stabilized linear power supply unit 2.5A - 13.8 Vdc
2	BR-SMCP50-Z2	Dual-zone processing board

OUTDOOR SYSTEMS

SISMA CA

PIEZOCERAMIC SYSTEM FOR FLOORING

SISMA CA is an intrusion detection system for the protection of flooring with concrete foundations. Integrated into the screed of the flooring, its sensors prove to be completely invisible.

SISMA CA employs passive pressure sensors supplied in prewired modules with coverage area between 1 and 4 square metres .

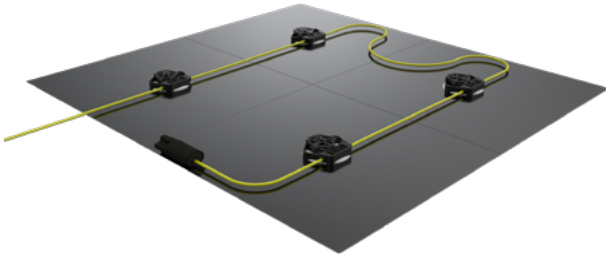

Prewired detection module for the protection of flooring between 1 and 6 square metres. The sensor-module is composed of 4, 6, 8, 10, 12, 16, 20 and 24 pressure sensors, of prewired termination, 5-metre initial cable and punched elastomeric membrane foils (50 x 50 cm). It also includes one pack of eco-friendly, cement based adhesive to fix the sensors to the concrete slab.

COMPLIANCE

SENSOR (if connected to BR-SMCA-Z1 or SC-SMCA-CTRL):

- **Directive 2014/30/EU (EMC)**
 - EN 50130-4:2011+A1:2014
 - EN 61000-6-3:2007+A1:2011
- **Directive 2011/65/EU (RoHS)**
 - EN 50581:2012
- **CEI 79-2 (2nd edition)**

CONNECTION CABLE: please see CV-SMCA on page 158.

TECHNICAL FEATURES

SENSOR:

- **Environmental class:** IV (designed in accordance with Directive EN 50130-5)
- **Dimensions:** 115 x 26 mm (Ø x H)
- **Material:** ABS body, sealed with epoxy
- **Operating temperature:** -40 ÷ +80 °C
- **Relative humidity:** 0 – 100%
- **IP rating:** IP68

ELASTOMERIC MEMBRANE:

- **Dimensions:** 50 x 50 cm (L x H)
- **Material:** SBR rubber

CONNECTION CABLE: please see CV-SMCA on page 158.

TERMINATION: please see TBX-SMCA on page 160.

CEMENT-BASED ADHESIVE: Kerakoll BIOGEL NO LIMITS.



The MD-SMCA sensor-module must be connected to BR-SMCA-Z1 processing board or to SC-SMCA-PU interface boards by means of CV-SMCA cable. The length of the cable connecting the sensor-string to the relevant processing board cannot be more than 150 metres.



The sensor-module must be integrated into the concrete screed. The latter must be between 6 and 10 cm thick and laid on an armoured concrete slab which must be at least 10 cm thick.



If you need to protect areas greater than 6 m², you can place more sensor-modules side by side.

SISMA CA sensor-modules is available in the following versions:

PART NUMBER	DESCRIPTION	NO. OF SENSORS EACH STRING	LENGTH
MD4-SMCA	Sensor-modules	4	1 m ²
MD6-SMCA	Sensor-modules	6	1.5 m ²
MD8-SMCA	Sensor-modules	8	2 m ²
MD10-SMCA	Sensor-modules	10	2.5 m ²
MD12-SMCA	Sensor-modules	12	3 m ²
MD16-SMCA	Sensor-modules	16	4 m ²
MD20-SMCA	Sensor-modules	20	5 m ²
MD24-SMCA	Sensor-modules	24	6 m ²



Tinned copper six-wire shielded cable for the connection of MD-SMCA sensor-modules to BR-SMCA-Z1 processing board or to BR-XS-SMCAPU interface board.

COMPLIANCE

- CEI 20-11, CEI 20-14 p.q.a., CEI 20-35/1-2
- EN 50363, EN 60332-1-2
- IEC 60332-1
- Directive 2014/35/EU
- Directive 2011/65/EU (RoHS)

TECHNICAL FEATURES

- **Diameter:** 7.5 mm (+/- 0,2)
- **Conductors:** stranded tinned copper
- **Cross sectional area:** 0.25 mm²
- **Operating temperature:**
 - -40 ÷ +80 °C (fixed installation)
 - -15 ÷ +80 °C (mobile installation)
- **Insulation voltage:** 0.6/1 kV
- **Insulation:** polyolefin according to UL 1581
- **Lay:** laying up of the two elements in pair
- **Total lay up:** laying up in round shape, with optional fillers
- **Shielding:** Aluminium/Polyester foil screen (coverage >100%) with tinned copper drain wire and tinned copper braid (coverage >70%)
- **Taping:** polyester foil
- **Jacket:** special flame retardant oil resistant PVC compound (according to CEI 20-11, EN 50363), quality TM2-RZ
- **Bending radius:** 15 times outer diameter
- **Use:** this cable can be installed in a group of cables with max operating voltage of U_o/U 0.6/1 kV max
- **Colour:** yellow

SISMA CA/SISMA CA PF cable is available in hanks of 50, 100 and 200 metres and in reels of 500 metres.

PART NUMBER	DESCRIPTION	LENGTH	COLOUR
CV-SMCA-50	Connection cable	50 m	YELLOW
CV-SMCA-100	Connection cable	100 m	YELLOW
CV-SMCA-200	Connection cable	200 m	YELLOW
CV-SMCA-500	Connection cable	500 m	YELLOW



Junction case for SISMA CA sensor-modules.
Supplied with a printed circuit board to simplify the wiring procedures.

COMPLIANCE

IF CONNECTED TO MD-SMCA:

- **Directive 2014/30/EU (EMC)**
 - EN 50130-4:2011+A1:2014
 - EN 61000-6-3:2007+A1:2011
- **Directive 2011/65/EU (RoHS)**
 - EN 50581:2012

TECHNICAL FEATURES

- **Environmental class:** IV (designed in accordance with Directive EN 50130-5)
- **Dimensions:** 52 x 37 x 133 mm (major axis x minor axis x H)
- **Gross weight:** 93 g
- **Net weight:** 60 g
- **Material:** glass fiber reinforced polyamide PA6-GF30
- **Colour:** black
- **Operating temperature:** -40 ÷ +80 °C
- **Relative humidity:** 0 – 100% (after sealing with RP-100 PUR cast resin)



To be wired with CV-SMCA cable and to be sealed with RP-100 two-component PUR cast resin.

PART NUMBER	DESCRIPTION	COLOUR
JBX-SMCA	Junction case	BLACK



Termination case for SISMA CA sensor-modules. Supplied with a printed circuit board to simplify the wiring procedures. The circuit is provided with a temperature transducer.

COMPLIANCE

IF CONNECTED TO MD-SMCA:

- **Directive 2014/30/EU (EMC)**
 - EN 50130-4:2011
 - EN 61000-6-3:2007+A1:2011
- **Directive 2011/65/EU (RoHS)**
 - EN 50581:2012

TECHNICAL FEATURES

- **Environmental class:** IV (designed in accordance with Directive EN 50130-5)
- **Dimensions:** 52 x 37 x 133 mm (major axis x minor axis x H)
- **Gross weight:** 93 g
- **Net weight:** 60 g
- **Material:** glass fiber reinforced polyamide PA6-GF30
- **Colour:** black
- **Operating temperature:** -40 ÷ +80 °C
- **Relative humidity:** 0 – 100% (after sealing with RP-100 PUR cast resin)



To be wired with CV-SMCA cable and to be sealed with RP-100 two-component PUR cast resin.



The sensor-modules are supplied with prewired termination.

PART NUMBER	DESCRIPTION	COLOUR
TBX-SMCA	Termination case	BLACK



Microprocessor electronic board which manages one SISMA CA or SISMA CA PF sensor-module.

This board amplifies, digitizes and analyses the signals coming from the sensor-modules, discriminating the typical signals of an intrusion attempt from the ones generated by environmental nuisances. The board is equipped with Ethernet interface and IP Native support.

COMPLIANCE

IF CONNECTED TO MD-SMCA:

- **Directive 2014/30/EU (EMC)**
 - EN 50130-4:2011+A1:2014
 - IEC 61000-6-4:2018
- **Directive 2011/65/EU (RoHS)**
 - EN 50581:2012
- **CEI 79-2 (2nd edition)**

TECHNICAL FEATURES

- **Dimensions:** 178 x 90 x 40 mm (W x H x D)
- **Packaging dimensions:** 190 x 95 x 50 mm (W x H x D)
- **Gross weight:** 368 g
- **Net weight:** 240 g
- **Power supply:** 12 Vdc (+/- 25%)
- **Current:** 110 mA (max)
- **Operating temperature:** -25 ÷ +80 °C
- **Relative humidity:** <95% non condensing
- **Management capability:** 1 SISMA CA or CA PF sensor-module
- **Inputs:** 2 digital opto-isolated, configurable by service software
- **NC relay outputs (positive security):**
 - 1 for sensor-module alarm
 - 1 for sensor-module prealarm
 - 1 for sensor-module tamper
 - 1 for low supply voltage, service activity in progress board operating anomalies
- **Communication port:**
 - USB (PC link)
 - Ethernet
 - DEA NET bus
- **Calibration, settings and event management via software**
- **CPU:** 32 bit, 168 MHz
- **Digital memory:** more than 20.000 events
- **Service software licence included**

PART NUMBER	DESCRIPTION
BR-SMCA-Z1	Single-zone processing board

CONTROLLER BOARD FOR BR-XS-SMCAPU

PART NUMBER

BR-XS-CTRL32

NEW



Controller board which manages up to 32 XENSITY sensors/peripheral devices, **including a maximum of 24 BR-XS-SMCAPU boards**. It has the function to supply power, check the operating status and receive signals from each device connected to the bus, store them in an internal memory making this information available through relay contacts, DEA NET proprietary network or IP network. The service software enables you to configure and monitor, locally or from remote station, all the detectors and the relay expansion boards (if any) connected to the controller board.

COMPLIANCE

IF CONNECTED TO XENSITY SENSOR/PERIPHERAL DEVICES:

- **Directive 2014/30/EU (EMC)**
 - › EN 50130-4:2011+A1:2014
 - › EN 61000-6-3:2007+A1:2011
- **Directive 2011/65/EU (RoHS)**
 - › EN 50581:2012
- **Standard EN 50131-1:2006+A1:2009+A2:2017**
 - › EN 50131-2-6:2008
 - › EN 50131-2-8:2016



TECHNICAL FEATURES

- **Security grade:** Grade 3 certified
(EN 50131-2-6:2008 if connected to SN-XS-FDRM)
(EN 50131-2-8:2016 if connected to SN-XS-FWL)
- **Dimensions:** 178 x 116 x 30 mm (W x H x D)
- **Packaging dimensions:** 235 x 170 x 70 mm (W x H x D)
- **Gross weight:** 604 g
- **Net weight:** 302 g
- **Power supply:** 12 Vdc (+/-25%)
- **Current:** 0.5 A (max)
- **Operating temperature:**
 - -10 ÷ +40 °C
 - -25 °C ÷ +70 °C (non certified)
- **Relative humidity:** <95% non condensing
- **Management capability:** up to 32 sensors/peripheral devices (max 24 BR-XS-SMCAPU)
- **Inputs:** 4 digital opto-isolated
- **NC relay outputs (positive security):**
 - general intrusion alarm
 - general tamper
 - low supply voltage/service activities/electronic board fault
 - sensor fail/self-test failed
 - bus link loss
 - 8 programmable
- **Auxiliary C/NC relay outputs:** up to 64 on 4 BR-XS-RE16L
- **OC outputs :** 2 programmable
- **Communication port:**
 - Ethernet (RJ45)
 - USB (PC link)
 - DEA NET bus
 - connector for flat cable (BR-XS-RE16L)
- **Calibrations and configurations using service software**
- **CPU:** 32 bit
- **Digital memory:** more than 20.000 events
- **Service software licence included**



BR-XS-CTRL32 must be installed inside a case protected against opening.



BR-XS-PU and BR-XS-GR boards, when connected to BR-XS-CTRL32, are managed as sensors.



BR-XS-CTRL32 can manage up to 4 BR-XS-RE16L expansion boards through dedicated communication interface.

PART NUMBER

BR-XS-CTRL32

DESCRIPTION

Controller board for the management of 32 sensors/peripheral devices

CONTROLLER BOARD FOR BR-XS-SMCAPU

PART NUMBER

BR-XS-CTRL64

NEW



Controller board which manages up to 64 XENSITY sensors/peripheral devices, **among which a maximum of 24 BR-XS-SMCAPU boards**. It has the function to supply power, check the operating status and receive signals from each device connected to the bus, store them in an internal memory making this information available through relay contacts, DEA NET proprietary network or IP network. The service software enables you to configure and monitor, locally or from remote station, all the detectors and the relay expansion boards (if any) connected to the controller board.

COMPLIANCE

IF CONNECTED TO XENSITY SENSOR/PERIPHERAL DEVICES:

- **Directive 2014/30/EU (EMC)**
 - EN 50130-4:2011+A1:2014
 - EN 61000-6-3:2007+A1:2011
- **Directive 2011/65/EU (RoHS)**
 - EN 50581:2012
- **Standard EN 50131-1:2006+A1:2009**
 - EN 50131-2-6:2008
 - EN 50131-2-8:2016



TECHNICAL FEATURES

- **Security grade:** Grade 3 certified
(EN 50131-2-6:2008 if connected to SN-XS-FDRM)
(EN 50131-2-8:2016 if connected to SN-XS-FWL)
- **Dimensions:** 178 x 116 x 30 mm (W x H x D)
- **Packaging dimensions:** 235 x 170 x 70 mm (W x H x D)
- **Gross weight:** 604 g
- **Net weight:** 302 g
- **Power supply:** 12 Vdc (+/-25%)
- **Current:** 0.5 A (max)
- **Operating temperature:**
 - -10 ÷ +40 °C
 - -25 °C ÷ +70 °C (non certified)
- **Relative humidity:** <95% non condensing
- **Management capability:** up to 64 sensors/peripheral devices (max 24 BR-XS-SMCAPU)
- **Inputs:** 4 digital opto-isolated
- **NC relay outputs (positive security):**
 - general intrusion alarm
 - general tamper
 - low supply voltage/service activities/electronic board fault
 - sensor fail/self-test failed
 - bus link loss
 - 8 programmable
- **Auxiliary C/NC relay outputs:** up to 96 on 6 BR-XS-RE16L
- **OC outputs :** 2 programmable
- **Communication port:**
 - Ethernet (RJ45)
 - USB (PC link)
 - DEA NET bus
 - connector for flat cable (BR-XS-RE16L)
- **Calibrations and configurations using service software**
- **CPU:** 64 bit
- **Digital memory:** more than 20.000 events
- **Service software licence included**



BR-XS-CTRL64 must be installed inside a case protected against opening.



BR-XS-PU and BR-XS-GR boards, when connected to BR-XS-CTRL64, are managed as sensors.



BR-XS-CTRL64 can manage up to 6 BR-XS-RE16L expansion boards through dedicated communication interface.

PART NUMBER

BR-XS-CTRL64

DESCRIPTION

Controller board for the management of 64 sensors/peripheral devices

INTERFACE PERIPHERAL BOARD FOR SISMA CA/CA PF

PART NUMBER

BR-XS-SMCAPU



NEW



Interface board for one SISMA CA/CA PF sensor-module which amplifies the signals coming from the sensor-module and transmit them to BR-XS-CTRL32/64 board by means of XENSITY bus.

COMPLIANCE

IF CONNECTED TO BR-XS-CTRL32 OR BR-XS-CTRL64:

- **Directive 2014/30/EU (EMC)**
 - EN 50130-4:2011+A1:2014
 - EN 61000-6-3:2021
- **Directive 2011/65/EU (RoHS)**
 - EN 50581:2012
- **CEI 79-2 (2nd edition)**

TECHNICAL FEATURES

- **Dimensions:** 83 x 80 x 40 mm (W x H x D)
- **Packaging dimensions:** 85 x 110 x 60 mm (W x H x D)
- **Gross weight:** 115 g
- **Net weight:** 62 g
- **Power supply:** by means of XENSITY bus (12 Vdc)
- **Current:** 5 mA (max)
- **Operating temperature:** -25 °C ÷ +80 °C
- **Relative humidity:** <95% non condensing
- **Management capability:**
 - 1 SISMA CA/CA PF sensor-module
- **Inputs:**
 - 1 SISMA CA/CA PF sensor-module
 - XENSITY bus
- **Configuration and programming by means of the control board**



Each peripheral device manages one SISMA CA/CA PF sensor-module.

SISMA CA

PART NUMBER

BR-XS-SMCAPU

DESCRIPTION

Interface peripheral board for SISMA CA/CA PF

SMCA NET ADAPTER BOARD

PART NUMBER
BR-XS-SMCAPU-ADP



NEW

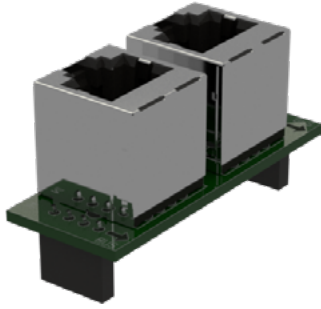

Adapter board which allows the connection of BR-XS-SMCAPU interface board to the SC-SMCA-CTRL control board on SMCA NET bus.

COMPLIANCE

IF CONNECTED TO BR-XS-SMCAPU:

- **Directive 2014/30/EU (EMC)**
 - EN 50130-4:2011
 - EN 61000-6-3:2007+A1:2011
- **Directive 2011/65/EU (RoHS)**
 - EN 50581:2012

TECHNICAL FEATURES

- **Dimensions:** 48 x 19 x 27 mm (W x H x D)
- **Gross weight:** 16.6 g
- **Net weight:** 9.9 g
- **Power supply:** by means of BR-XS-SMCAPU board
- **Operating temperature:** -25 °C ÷ +70 °C
- **Relative humidity:** <95% non condensing

SIGMA
CA

PART NUMBER	DESCRIPTION
BR-XS-SMCAPU-ADP	SMCA NET adapter board

16-RELAY EXPANSION BOARD

PART NUMBER
BR-XS-RE16L



NEW

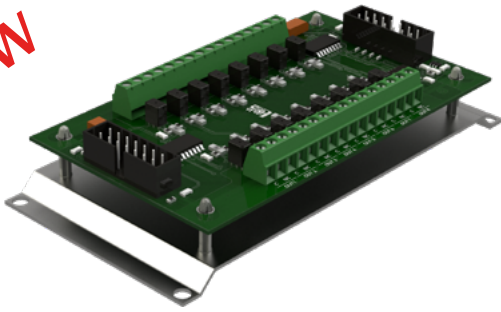

16-relay expansion board to make the alarm signals available through C/NC contacts.
All the relay outputs can be programmed via software from BR-XS-CTRL32 or BR-XS-CTRL64 Controller boards.

COMPLIANCE

IF CONNECTED TO BR-XS-CTRL32 OR BR-XS-CTRL64:

- **Directive 2014/30/EU (EMC)**
 - EN 50130-4:2011+A1:2014
 - EN 61000-6-3:2007+A1:2011
- **Directive 2011/65/EU (RoHS)**
 - EN 50581:2012

TECHNICAL FEATURES

- **Dimensions:** 130 x 64 x 29 mm (W x H x D)
- **Packaging dimensions:** 145 x 70 x 67 mm (W x H x D)
- **Gross weight:** 150 g
- **Net weight:** 70 g
- **Power supply:** provided by controller board
- **Current:** 30 mA (max)
- **Operating temperature:** -25 ÷ +80 °C
- **Relative humidity:** <95% non condensing
- **C/NC relay outputs:** 16-relay outputs programmable from service software
- **Connections:** 14-pin connector for flat cable



BR-XS-RE16L works with BR-XS-CTRL32 and BR-XS-CTRL64 Controller boards only.



The board must be installed inside a case protected against opening.

PART NUMBER

BR-XS-RE16L

DESCRIPTION

16-relay expansion board for BR-XS-CTRL32 and BR-XS-CTRL64

SISMA
CA

1-RELAY EXPANSION BOARD

PART NUMBER
SC-ER1

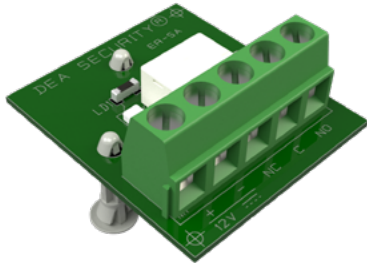

1-relay expansion board to convert OC outputs into C/NC/NO contacts.

COMPLIANCE

IF CONNECTED TO BOARDS WHICH PROVIDE FOR ITS USE:

- Directive 2014/30/EU (EMC)

TECHNICAL FEATURES

- **Dimensions:** 36 x 32 x 31 mm (W x H x D)
- **Gross weight:** 13 g
- **Power supply:** 12 Vdc (+/- 25%)
- **Current:** 12 mA
- **Operating temperature:** -25 ÷ +80 °C
- **Relative humidity:** <95% non condensing
- **Input:** 1 per OC signal
- **NC relay outputs (1 A):** C/NC/NO

PART NUMBER	DESCRIPTION
SC-ER1	1-relay expansion board (OC into C/NC/NO)

APPLICATION EXAMPLES

MD4-SMCA SENSOR-MODULES

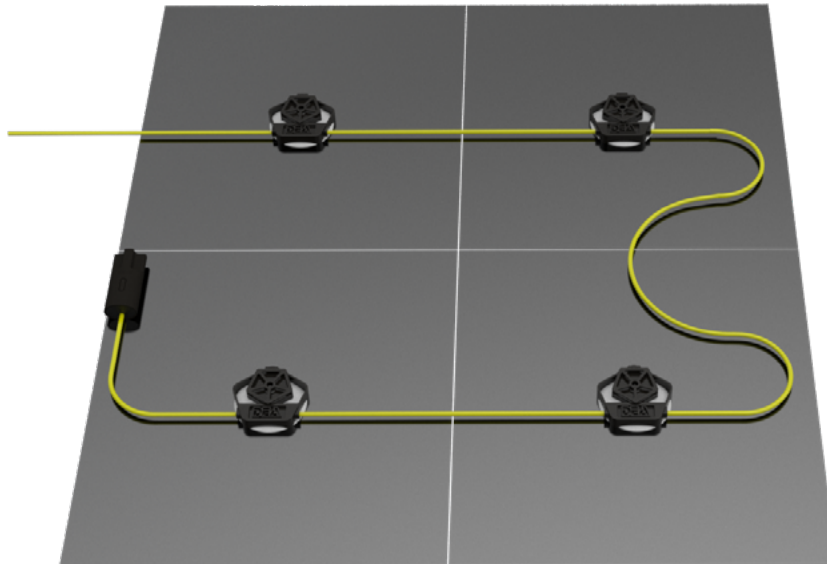

INSTALLATION DEPTH

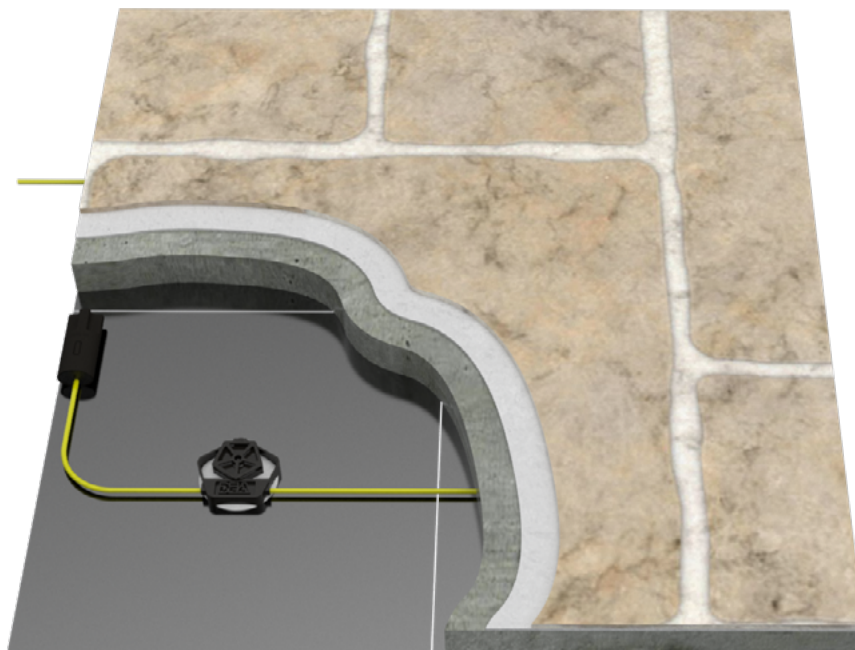
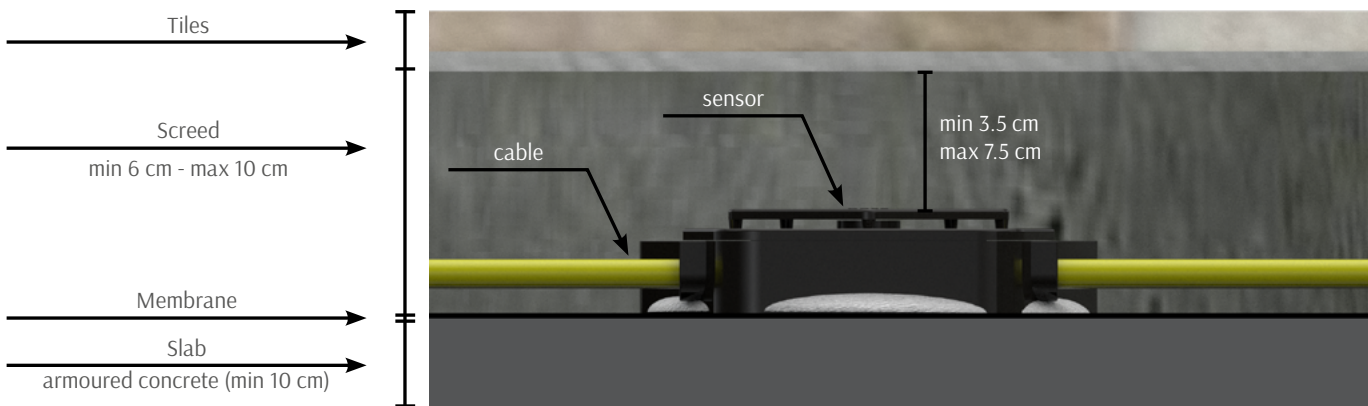

SISMA CA detects:

- an intruder standing on a protected area (Case A);
- an intruder crossing a protected area (Case B).

STANDING ON A PROTECTED AREA (Case A):

AN INTRUDER STANDING ON THE AREA WHILE ATTEMPTING TO FORCE THE DOOR OPEN OR BREAK IT THROUGH.

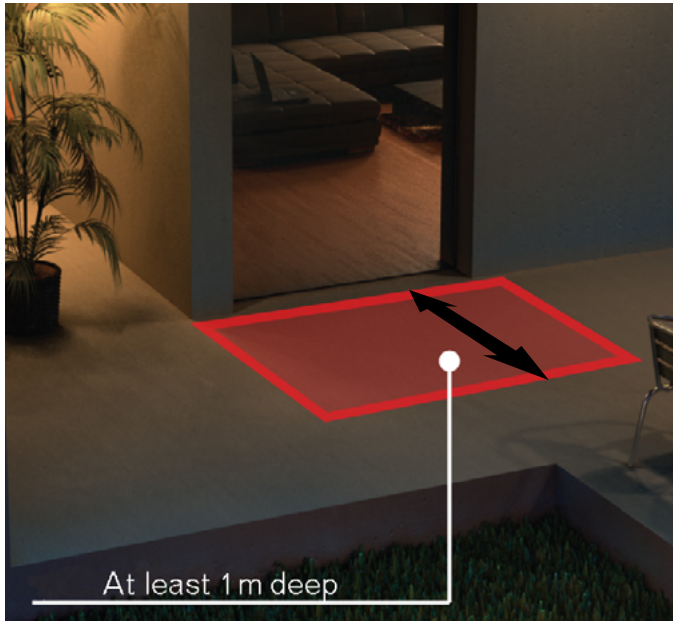

The protected area must be as wide as the door/window and must be 1 metre deep.

CROSSING THE PROTECTED AREA (Case B):

AN INTRUDER CROSSING THE PROTECTED AREA.

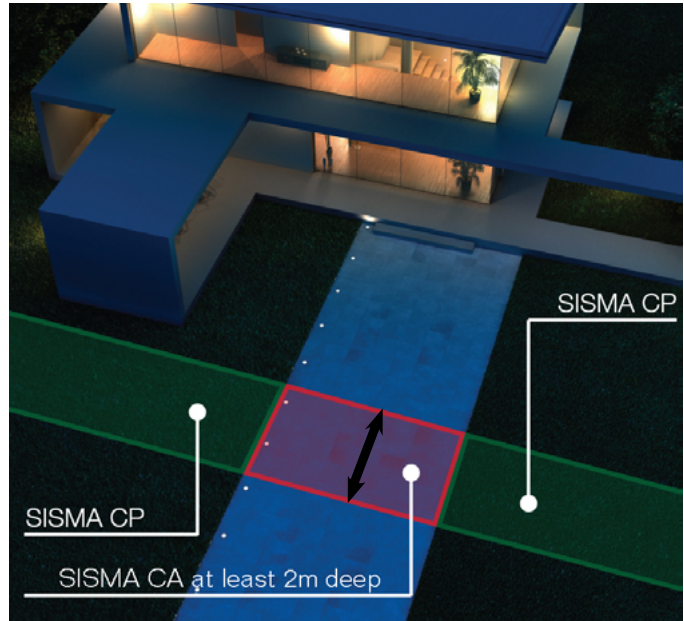

The protected area must be as wide as the path and must be 2 metres long minimum.

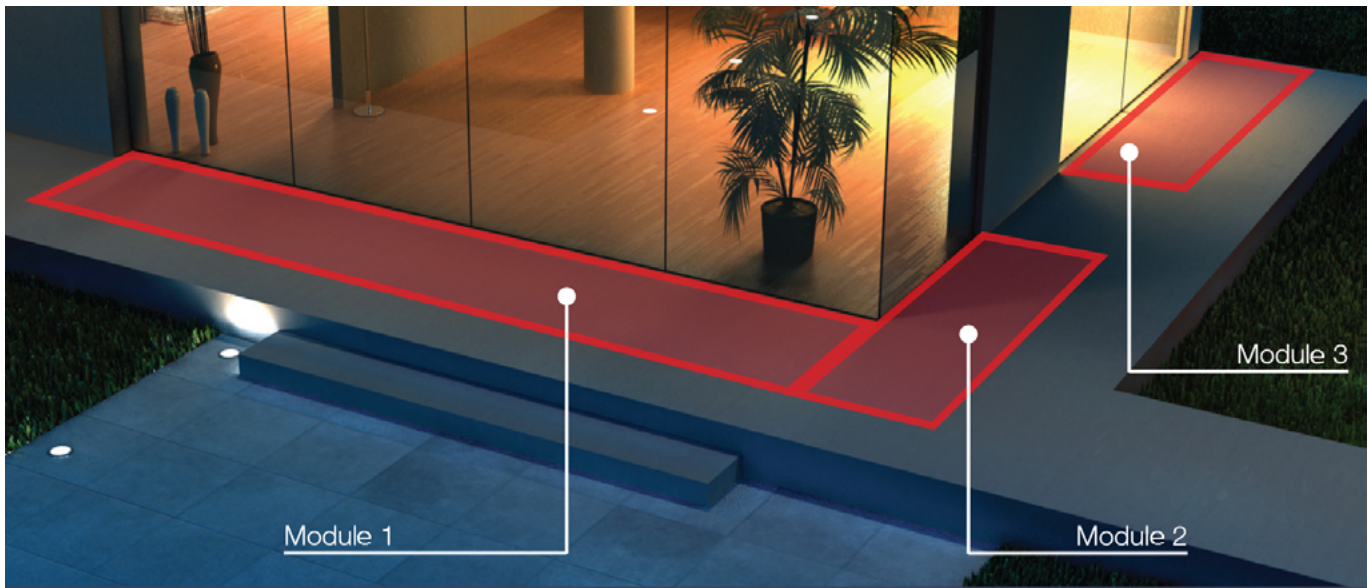

If the area to be protected exceeds the capacity of each single sensor-module, you need to place more sensor-modules side by side. Each module has to be managed by its own processing board BR-SMCA-Z1 or SC-SMCA-PU.

To manage and process the signals coming from the sensor-modules, two solutions are possible:

1. BR-SMCA-Z1 single-zone processing board, for stand-alone systems;
2. SC-SMCA-CTRL + SC-SMCA-PU + SC-ER8 modular system, which manages up to 24 zones. Each sensor-module is connected to an SC-SMCA-PU interface board, which is in turn connected to SC-SMCA-CTRL by means of SMCA NET bus. SC-SMCA-CTRL can be connected up to three SC-ER8 expansion boards, each of them providing 8 configurable relays.

SOLUTION 1: EACH BR-SMCA-Z1 BOARD MANAGES ONE SENSOR-MODULE

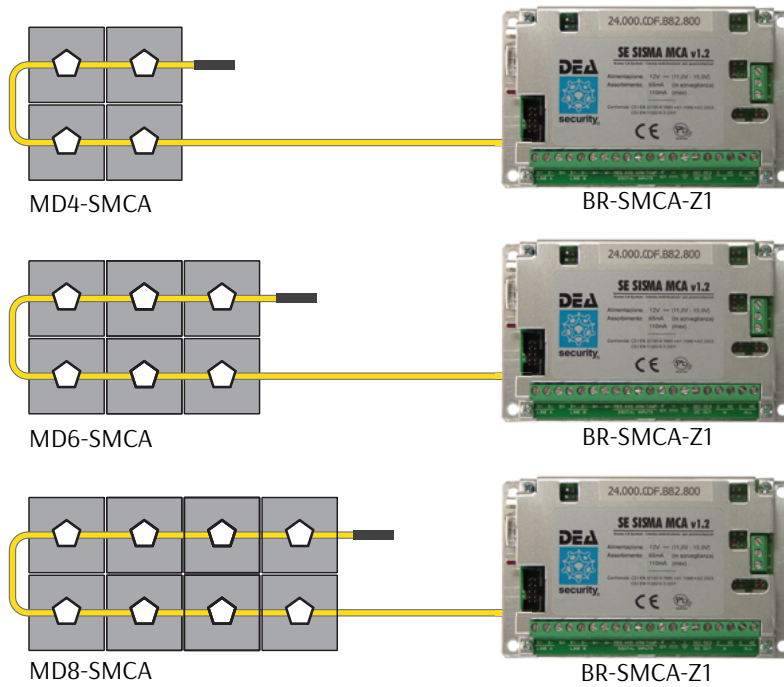

SOLUTION 2: SC-SMCA-PU BOARDS (UP TO 24) COMMUNICATE WITH BR-XS-CTRL32/64 BOARD BY MEANS OF SMCA NET

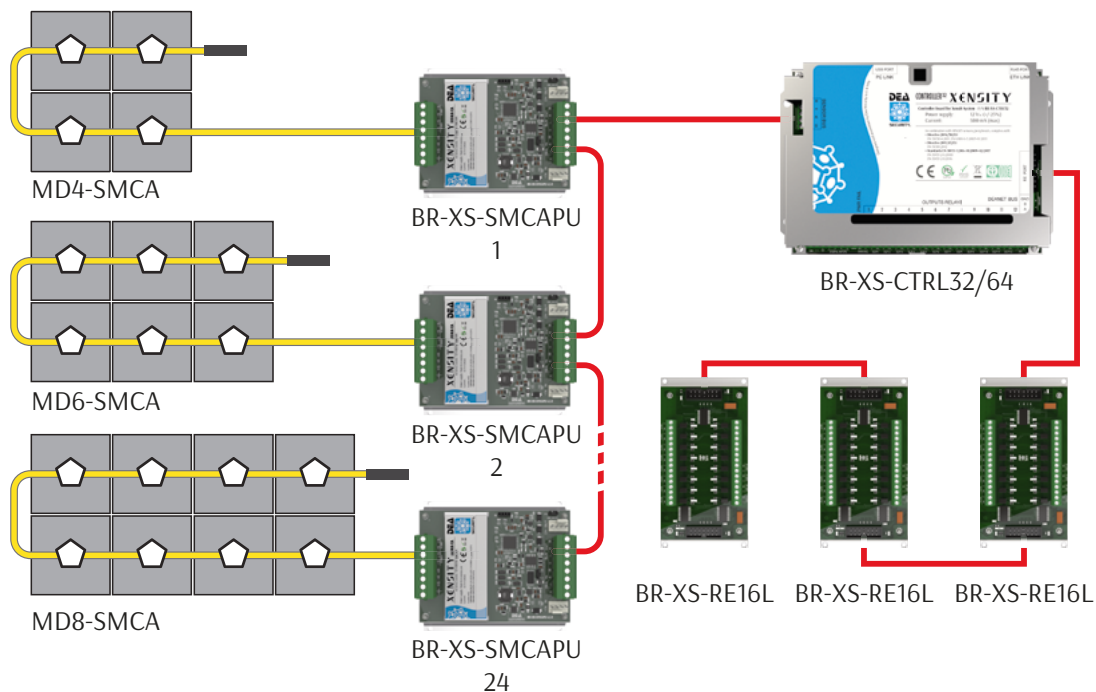

FLOORING PROTECTION:

- no. 6 sensor-modules model MD4-SMCA (1 m²);
- no. 4 sensor-modules model MD8-SMCA (2 m²);

CENTRALIZATION SYSTEM:

- no. 1 centralization cabinet (Box0) containing the centralization board and the interface boards.

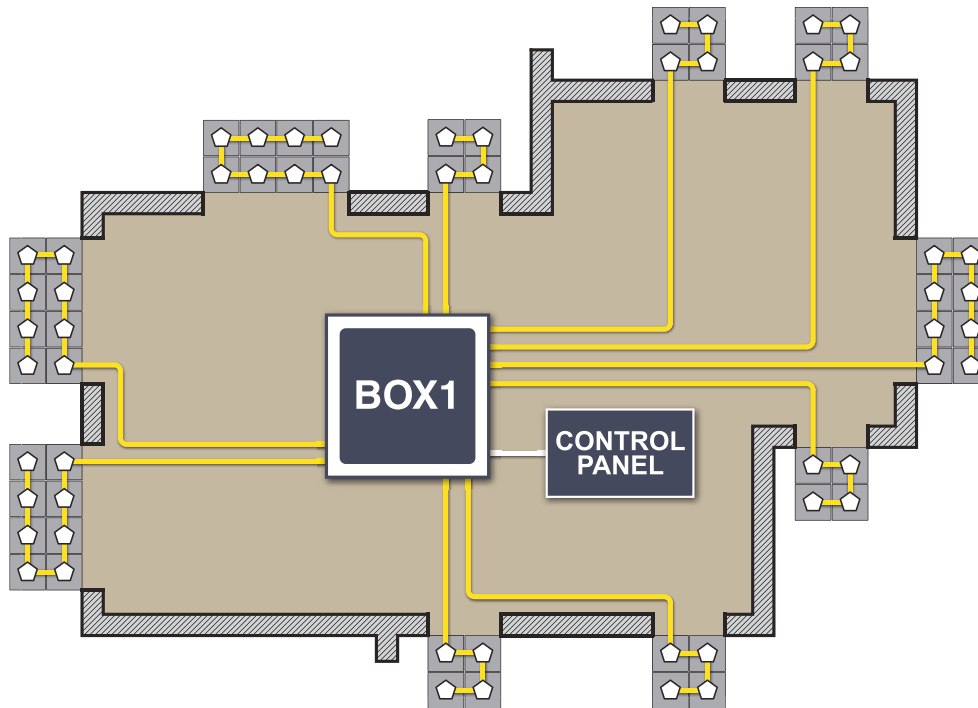

LIST OF PARTS TO MAKE A SYSTEM AS PER THE ABOVE EXAMPLE:

Sensor-modules, connection cable and wiring accessories

Q.TY	PART NUMBER	DESCRIPTION
6	MD4-SMCA	Sensor-module for the protection of 1 m ²
4	MD8-SMCA	Sensor-module for the protection of 2 m ²
1	CV-SMCA-100	Connection cable between the sensor-module and the SC-SMCA-PU boards
10	JBX-SMCA	Junction case
10	RP-100	Two-component PUR cast resin to seal junction and termination cases

Cabinet Box0 e relative schede elettroniche

Q.TY	PART NUMBER	DESCRIPTION
1	AP-4C	Preassembled polyester cabinet
1	AL-DN-DEAPW	Microprocessor stabilized linear power supply unit 2.5A - 13.8 Vdc
1	BR-XS-CTRL32	Centralization board for BR-XS-SMCAPU boards (up to 24)
10	BR-XS-SMCAPU	Interface board for one sensor-module
2	BR-XS-RE16L	16-relay expansion board

OUTDOOR SYSTEMS

SISMA CA PF

PIEZOCERAMIC SYSTEM FOR RAISED FLOORS

SISMA CA PF is an intrusion detection system for the protection of raised floors. It creates an invisible detection area since the sensors are placed under the structure supporting the floor.

SISMA CA PF employs passive pressure sensors supplied in modules with coverage area between 6 and 24 square metres.



Prewired sensor-module for the protection of raised floors with a surface between 6 and 24 square metres. The sensor-module is composed of 4, 6, 8, 12 or 16 pressure sensors and is provided with prewired termination and 5-metre initial cable.

COMPLIANCE

SENSOR (if connected to BR-SMCA-Z1 or SC-SMCAPF-CTRL):

- **Directive 2014/30/EU (EMC)**
 - EN 50130-4:2011+A1:2014
 - EN 61000-6-3:2007+A1:2011
- **Directive 2011/65/EU (RoHS)**
 - EN 50581:2012
- **CEI 79-2 (2nd edition)**

CONNECTION CABLE: please see CV-SMCA on page 175.

TECHNICAL FEATURES

SENSOR:

- **Environmental class:** IV (designed in accordance with Directive EN 50130-5)
- **Dimensions:** 106 x 25 mm (Ø x H)
- **Material:** ABS body, sealed with epoxy
- **Operating temperature:** -40 ÷ +80 °C
- **Relative humidity:** 0 – 100%

CONNECTION CABLE: please see CV-SMCA on page 175.

TERMINATION: please see TBX-SMCAPF on page 177.



The MD-SMCAPF sensor-module must be connected to BR-SMCA-Z1 processing board or to SC-SMCAPF-PU interface boards by means of CV-SMCA cable. The length of the cable connecting the sensor-string to the relevant processing board cannot be more than 150 metres.



SISMA CA PF sensors must be placed under the pedestals supporting the raised floor, adjusting their height accordingly.



If you need to protect areas greater than 24 m², you can place more sensor-modules side by side.

SISMA CA PF sensor-modules is available in the following versions:

PART NUMBER	DESCRIPTION	NO. OF SENSORS EACH STRING	COVERAGE AREA
MD4-SMCAPF	Sensor-modules	4	6 m ²
MD6-SMCAPF	Sensor-modules	6	9 m ²
MD8-SMCAPF	Sensor-modules	8	12 m ²
MD12-SMCAPF	Sensor-modules	12	18 m ²
MD16-SMCAPF	Sensor-modules	16	24 m ²



Tinned copper six-wire shielded cable for the connection of MD-SMCA PF sensor-modules to BR-SMCA-Z1 processing board or to BR-XS-SMCA PF interface board.

COMPLIANCE

- CEI 20-11, CEI 20-14 p.q.a., CEI 20-35/1-2
- EN 50363, EN 60332-1-2
- IEC 60332-1
- Directive 2014/35/EU
- Directive 2011/65/EU (RoHS)

TECHNICAL FEATURES

- **Diameter:** 7.5 mm (+/- 0,2)
- **Conductors:** stranded tinned copper
- **Cross sectional area:** 0.25 mm²
- **Operating temperature:**
 - -40 ÷ +80 °C (fixed installation)
 - -15 ÷ +80 °C (mobile installation)
- **Insulation voltage:** 0.6/1 kV
- **Insulation:** polyolefin according to UL 1581
- **Lay:** laying up of the two elements in pair
- **Total lay up:** laying up in round shape, with optional fillers
- **Shielding:** Aluminium/Polyester foil screen (coverage >100%) with tinned copper drain wire and tinned copper braid (coverage >70%)
- **Taping:** polyester foil
- **Jacket:** special flame retardant oil resistant PVC compound (according to CEI 20-11, EN 50363), quality TM2-RZ
- **Bending radius:** 15 times outer diameter
- **Use:** this cable can be installed in a group of cables with max operating voltage of U_o/U 0.6/1 kV max
- **Colour:** yellow

SISMA CA/SISMA CA PF cable is available in hanks of 50, 100 and 200 metres and in reels of 500 metres.

PART NUMBER	DESCRIPTION	LENGTH	COLOUR
CV-SMCA-50	Connection cable	50 m	YELLOW
CV-SMCA-100	Connection cable	100 m	YELLOW
CV-SMCA-200	Connection cable	200 m	YELLOW
CV-SMCA-500	Connection cable	500 m	YELLOW



Junction case for SISMA CA PF sensor-modules. Supplied with a printed circuit board to simplify the wiring procedures.

COMPLIANCE

IF CONNECTED TO MD-SMCA PF:

- **Directive 2014/30/EU (EMC)**
 - EN 50130-4:2011+A1:2014
 - EN 61000-6-3:2007+A1:2011
- **Directive 2011/65/EU (RoHS)**
 - EN 50581:2012

TECHNICAL FEATURES

- **Environmental class:** IV (designed in accordance with Directive EN 50130-5)
- **Dimensions:** 52 x 37 x 133 mm (major axis x minor axis x H)
- **Gross weight:** 93 g
- **Net weight:** 60 g
- **Material:** glass fiber reinforced polyamide PA6-GF30
- **Colour:** black
- **Operating temperature:** -40 ÷ +80 °C
- **Relative humidity:** 0 – 100% (after sealing with RP-100 PUR cast resin)



To be wired with CV-SMCA cable and to be sealed with RP-100 two-component PUR cast resin.

PART NUMBER	DESCRIPTION	COLOUR
JBX-SMCA	Junction case	BLACK



Termination case for SISMA CA PF sensor-modules. Supplied with a printed circuit board to simplify the wiring procedures.

COMPLIANCE

IF CONNECTED TO MD-SMCAPF:

- **Directive 2014/30/EU (EMC)**
 - EN 50130-4:2011+A1:2014
 - EN 61000-6-3:2007+A1:2011
- **Directive 2011/65/EU (RoHS)**
 - EN 50581:2012

TECHNICAL FEATURES

- **Environmental class:** IV (designed in accordance with Directive EN 50130-5)
- **Dimensions:** 52 x 37 x 133 mm (major axis x minor axis x H)
- **Gross weight:** 93 g
- **Net weight:** 60 g
- **Material:** glass fiber reinforced polyamide PA6-GF30
- **Colour:** black
- **Operating temperature:** -40 ÷ +80 °C
- **Relative humidity:** 0 – 100% (after sealing with RP-100 PUR cast resin)



To be wired with CV-SMCA cable and to be sealed with RP-100 two-component PUR cast resin.

PART NUMBER	DESCRIPTION	COLOUR
TBX-SMCAPF	Termination case	BLACK



Microprocessor electronic board which manages one SISMA CA or SISMA CA PF sensor-module. This board amplifies, digitizes and analyses the signals coming from the sensor-modules, discriminating the typical signals of an intrusion attempt from the ones generated by environmental nuisances. The board is equipped with Ethernet interface and IP Native support.

COMPLIANCE

IF CONNECTED TO MD-SMCA PF:

- **Directive 2014/30/EU (EMC)**
 - EN 50130-4:2011
 - EN 61000-6-3:2007+A1:2011
- **Directive 2011/65/EU (RoHS)**
 - EN 50581:2012
- **CEI 79-2 (2nd edition)**

TECHNICAL FEATURES

- **Dimensions:** 178 x 90 x 40 mm (W x H x D)
- **Packaging dimensions:** 190 x 95 x 50 mm (W x H x D)
- **Gross weight:** 368 g
- **Net weight:** 240 g
- **Power supply:** 12 Vdc (+/- 25%)
- **Current:** 110 mA (max)
- **Operating temperature:** -25 ÷ +80 °C
- **Relative humidity:** <95% non condensing
- **Management capability:** 1 SISMA CA or CA PF sensor-module
- **Inputs:** 2 digital opto-isolated, configurable by service software
- **NC relay outputs (positive security):**
 - 1 for sensor-module alarm
 - 1 for sensor-module prealarm
 - 1 for sensor-module tamper
 - 1 for low supply voltage, service activity in progress board operating anomalies
- **Communication port:**
 - USB (PC link)
 - Ethernet
 - DEA NET bus
- **Calibration, settings and event management via software**
- **CPU:** 32 bit, 168 MHz
- **Digital memory:** more than 20.000 events
- **Service software licence included**

PART NUMBER	DESCRIPTION
BR-SMCA-Z1	Single-zone processing board

CONTROLLER BOARD FOR BR-XS-SMCAPU

PART NUMBER

BR-XS-CTRL32

NEW



Controller board which manages up to 32 XENSITY sensors/peripheral devices, **including a maximum of 24 BR-XS-SMCAPU boards**. It has the function to supply power, check the operating status and receive signals from each device connected to the bus, store them in an internal memory making this information available through relay contacts, DEA NET proprietary network or IP network. The service software enables you to configure and monitor, locally or from remote station, all the detectors and the relay expansion boards (if any) connected to the controller board.

COMPLIANCE

IF CONNECTED TO XENSITY SENSOR/PERIPHERAL DEVICES:

- **Directive 2014/30/EU (EMC)**
 - › EN 50130-4:2011+A1:2014
 - › EN 61000-6-3:2007+A1:2011
- **Directive 2011/65/EU (RoHS)**
 - › EN 50581:2012
- **Standard EN 50131-1:2006+A1:2009+A2:2017**
 - › EN 50131-2-6:2008
 - › EN 50131-2-8:2016



TECHNICAL FEATURES

- **Security grade:** Grade 3 certified
(EN 50131-2-6:2008 if connected to SN-XS-FDRM)
(EN 50131-2-8:2016 if connected to SN-XS-FWL)
- **Dimensions:** 178 x 116 x 30 mm (W x H x D)
- **Packaging dimensions:** 235 x 170 x 70 mm (W x H x D)
- **Gross weight:** 604 g
- **Net weight:** 302 g
- **Power supply:** 12 Vdc (+/-25%)
- **Current:** 0.5 A (max)
- **Operating temperature:**
 - -10 ÷ +40 °C
 - -25 °C ÷ +70 °C (non certified)
- **Relative humidity:** <95% non condensing
- **Management capability:** up to 32 sensors/peripheral devices (max 24 BR-XS-SMCAPU)
- **Inputs:** 4 digital opto-isolated
- **NC relay outputs (positive security):**
 - general intrusion alarm
 - general tamper
 - low supply voltage/service activities/electronic board fault
 - sensor fail/self-test failed
 - bus link loss
 - 8 programmable
- **Auxiliary C/NC relay outputs:** up to 64 on 4 BR-XS-RE16L
- **OC outputs :** 2 programmable
- **Communication port:**
 - Ethernet (RJ45)
 - USB (PC link)
 - DEA NET bus
 - connector for flat cable (BR-XS-RE16L)
- **Calibrations and configurations using service software**
- **CPU:** 32 bit
- **Digital memory:** more than 20.000 events
- **Service software licence included**



BR-XS-CTRL32 must be installed inside a case protected against opening.



BR-XS-PU and BR-XS-GR boards, when connected to BR-XS-CTRL32, are managed as sensors.



BR-XS-CTRL32 can manage up to 4 BR-XS-RE16L expansion boards through dedicated communication interface.

PART NUMBER

BR-XS-CTRL32

DESCRIPTION

Controller board for the management of 32 sensors/peripheral devices

CONTROLLER BOARD FOR BR-XS-SMCAPU

PART NUMBER

BR-XS-CTRL64

NEW



Controller board which manages up to 64 XENSITY sensors/peripheral devices, **among which a maximum of 24 BR-XS-SMCAPU boards**. It has the function to supply power, check the operating status and receive signals from each device connected to the bus, store them in an internal memory making this information available through relay contacts, DEA NET proprietary network or IP network. The service software enables you to configure and monitor, locally or from remote station, all the detectors and the relay expansion boards (if any) connected to the controller board.

COMPLIANCE

IF CONNECTED TO XENSITY SENSOR/PERIPHERAL DEVICES:

- **Directive 2014/30/EU (EMC)**
 - EN 50130-4:2011+A1:2014
 - EN 61000-6-3:2007+A1:2011
- **Directive 2011/65/EU (RoHS)**
 - EN 50581:2012
- **Standard EN 50131-1:2006+A1:2009**
 - EN 50131-2-6:2008
 - EN 50131-2-8:2016



TECHNICAL FEATURES

- **Security grade:** Grade 3 certified
(EN 50131-2-6:2008 if connected to SN-XS-FDRM)
(EN 50131-2-8:2016 if connected to SN-XS-FWL)
- **Dimensions:** 178 x 116 x 30 mm (W x H x D)
- **Packaging dimensions:** 235 x 170 x 70 mm (W x H x D)
- **Gross weight:** 604 g
- **Net weight:** 302 g
- **Power supply:** 12 Vdc (+/-25%)
- **Current:** 0.5 A (max)
- **Operating temperature:**
 - -10 ÷ +40 °C
 - -25 °C ÷ +70 °C (non certified)
- **Relative humidity:** <95% non condensing
- **Management capability:** up to 64 sensors/peripheral devices (max 24 BR-XS-SMCAPU)
- **Inputs:** 4 digital opto-isolated
- **NC relay outputs (positive security):**
 - general intrusion alarm
 - general tamper
 - low supply voltage/service activities/electronic board fault
 - sensor fail/self-test failed
 - bus link loss
 - 8 programmable
- **Auxiliary C/NC relay outputs:** up to 96 on 6 BR-XS-RE16L
- **OC outputs :** 2 programmable
- **Communication port:**
 - Ethernet (RJ45)
 - USB (PC link)
 - DEA NET bus
 - connector for flat cable (BR-XS-RE16L)
- **Calibrations and configurations using service software**
- **CPU:** 64 bit
- **Digital memory:** more than 20.000 events
- **Service software licence included**



BR-XS-CTRL64 must be installed inside a case protected against opening.



BR-XS-PU and BR-XS-GR boards, when connected to BR-XS-CTRL64, are managed as sensors.



BR-XS-CTRL64 can manage up to 6 BR-XS-RE16L expansion boards through dedicated communication interface.

PART NUMBER

BR-XS-CTRL64

DESCRIPTION

Controller board for the management of 64 sensors/peripheral devices

INTERFACE PERIPHERAL BOARD FOR SISMA CA/CA PF

PART NUMBER

BR-XS-SMCAPU

NEW

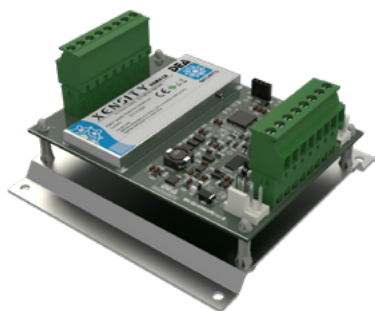

Interface board for one SISMA CA/CA PF sensor-module which amplifies the signals coming from the sensor-module and transmit them to BR-XS-CTRL32/64 board by means of XENSITY bus.

COMPLIANCE

IF CONNECTED TO BR-XS-CTRL32 OR BR-XS-CTRL64:

- **Directive 2014/30/EU (EMC)**
 - EN 50130-4:2011+A1:2014
 - EN 61000-6-3:2021
- **Directive 2011/65/EU (RoHS)**
 - EN 50581:2012
- **CEI 79-2 (2nd edition)**



TECHNICAL FEATURES

- **Dimensions:** 83 x 80 x 40 mm (W x H x D)
- **Packaging dimensions:** 85 x 110 x 60 mm (W x H x D)
- **Gross weight:** 115 g
- **Net weight:** 62 g
- **Power supply:** by means of XENSITY bus (12 Vdc)
- **Current:** 5 mA (max)
- **Operating temperature:** -25 °C ÷ +80 °C
- **Relative humidity:** <95% non condensing
- **Management capability:**
 - 1 SISMA CA/CA PF sensor-module
- **Inputs:**
 - 1 SISMA CA/CA PF sensor-module
 - XENSITY bus
- **Configuration and programming by means of the control board**



Each peripheral device manages one SISMA CA/CA PF sensor-module.

PART NUMBER	DESCRIPTION
BR-XS-SMCAPU	Interface peripheral board for SISMA CA/CA PF

SMCA NET ADAPTER BOARD

PART NUMBER
BR-XS-SMCAPU-ADP



NEW

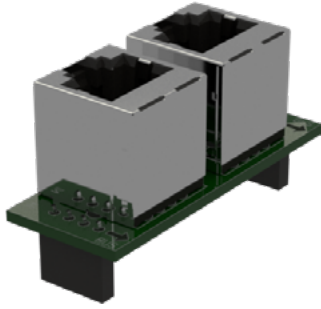

Adapter board which allows the connection of BR-XS-SMCAPU interface board to the SC-SMCA-CTRL control board on SMCA NET bus.

COMPLIANCE

IF CONNECTED TO BR-XS-SMCAPU:

- **Directive 2014/30/EU (EMC)**
 - EN 50130-4:2011
 - EN 61000-6-3:2007+A1:2011
- **Directive 2011/65/EU (RoHS)**
 - EN 50581:2012

TECHNICAL FEATURES

- **Dimensions:** 48 x 19 x 27 mm (W x H x D)
- **Gross weight:** xx g
- **Net weight:** xx g
- **Power supply:** by means of BR-XS-SMCAPU board
- **Operating temperature:** -25 °C ÷ +70 °C
- **Relative humidity:** <95% non condensing

GISMA
CA
PF

PART NUMBER	DESCRIPTION
BR-XS-SMCAPU-ADP	SMCA NET adapter board

16-RELAY EXPANSION BOARD

PART NUMBER
BR-XS-RE16L

NEW

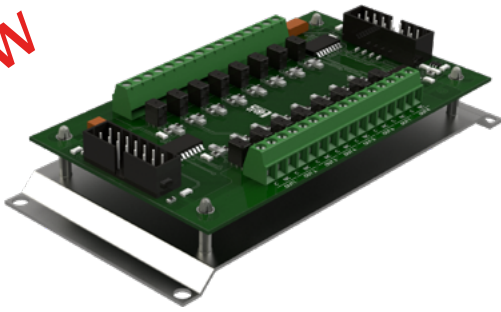

16-relay expansion board to make the alarm signals available through C/NC contacts.
All the relay outputs can be programmed via software from BR-XS-CTRL32 or BR-XS-CTRL64 Controller boards.

COMPLIANCE

IF CONNECTED TO BR-XS-CTRL32 OR BR-XS-CTRL64:

- **Directive 2014/30/EU (EMC)**
 - EN 50130-4:2011+A1:2014
 - EN 61000-6-3:2007+A1:2011
- **Directive 2011/65/EU (RoHS)**
 - EN 50581:2012

TECHNICAL FEATURES

- **Dimensions:** 130 x 64 x 29 mm (W x H x D)
- **Packaging dimensions:** 145 x 70 x 67 mm (W x H x D)
- **Gross weight:** 150 g
- **Net weight:** 70 g
- **Power supply:** provided by controller board
- **Current:** 30 mA (max)
- **Operating temperature:** -25 ÷ +80 °C
- **Relative humidity:** <95% non condensing
- **C/NC relay outputs:** 16-relay outputs programmable from service software
- **Connections:** 14-pin connector for flat cable



BR-XS-RE16L works with BR-XS-CTRL32 and BR-XS-CTRL64 Controller boards only.



The board must be installed inside a case protected against opening.

PART NUMBER

BR-XS-RE16L

DESCRIPTION

16-relay expansion board for BR-XS-CTRL32 and BR-XS-CTRL64

1-RELAY EXPANSION BOARD

PART NUMBER
SC-ER1

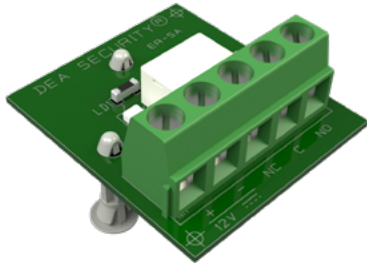

1-relay expansion board to convert OC outputs into C/NC/NO contacts.

COMPLIANCE

IF CONNECTED TO BOARDS WHICH PROVIDE FOR ITS USE:

- Directive 2014/30/EU (EMC)

TECHNICAL FEATURES

- **Dimensions:** 36 x 32 x 31 mm (W x H x D)
- **Gross weight:** 13 g
- **Power supply:** 12 Vdc (+/- 25%)
- **Current:** 12 mA
- **Operating temperature:** -25 ÷ +80 °C
- **Relative humidity:** <95% non condensing
- **Input:** 1 per OC signal
- **NC relay outputs (1 A):** C/NC/NO

GISMA
CA
PF

PART NUMBER	DESCRIPTION
SC-ER1	1-relay expansion board (OC into C/NC/NO)

APPLICATION EXAMPLES

INSTALLATION OF A SISMA CA PF SENSOR-MODULE

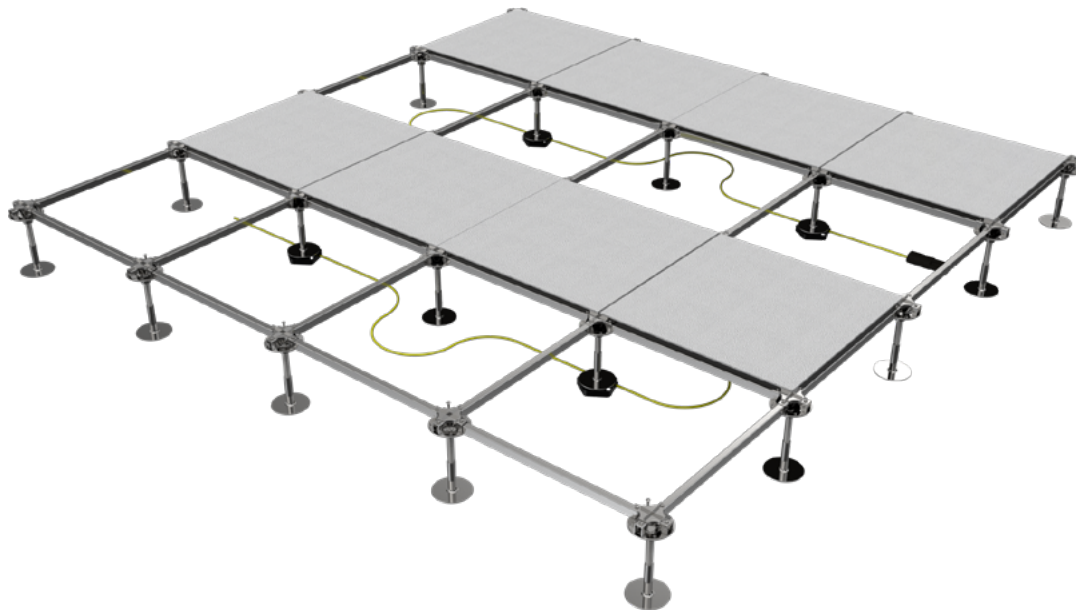
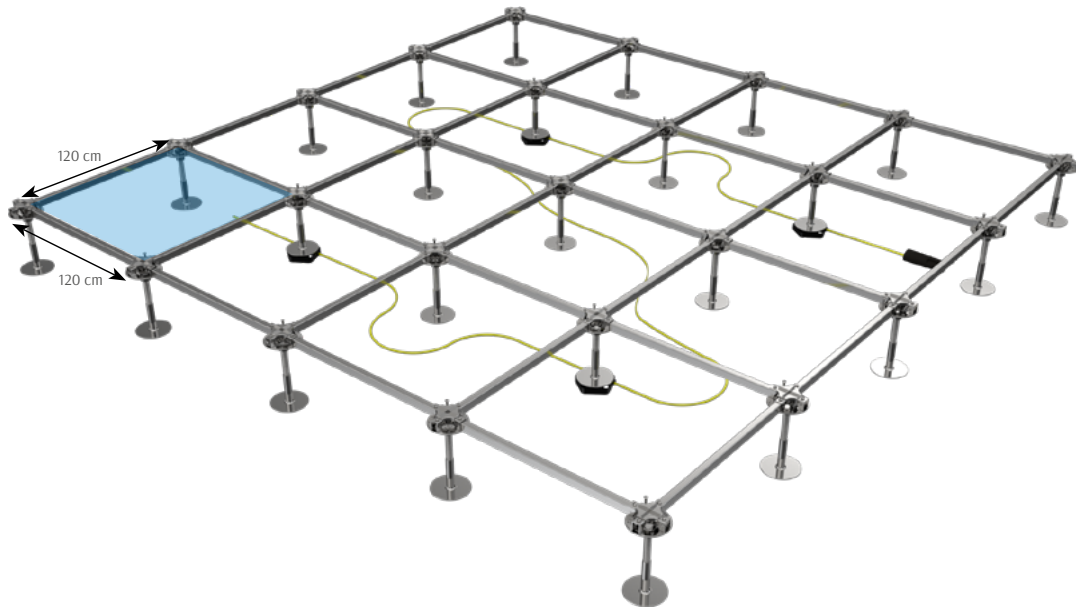

INSTALLATION DEPTH

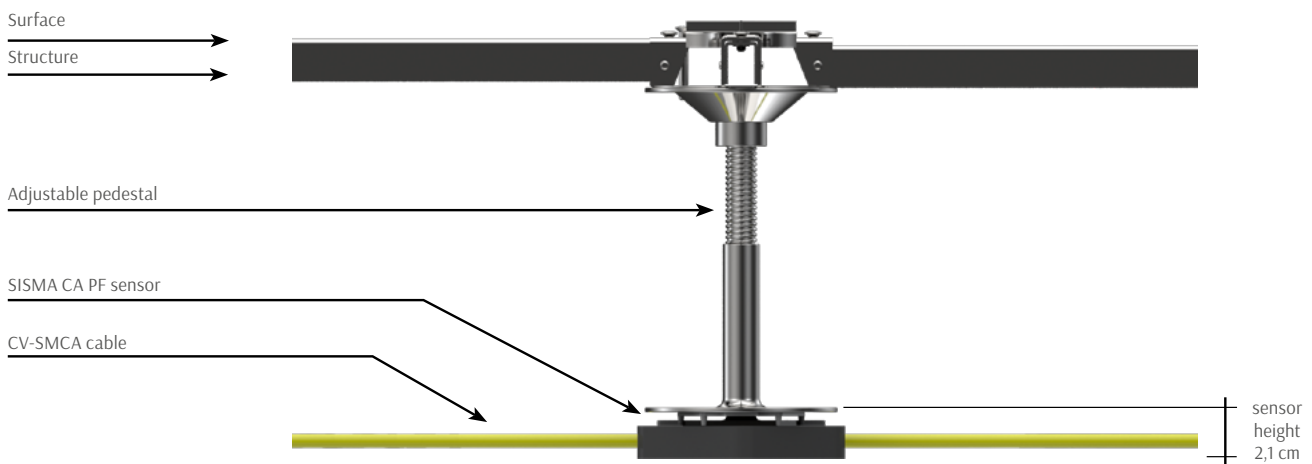

To manage and process the signals coming from the sensor-modules, two solutions are possible:

1. BR-SMCA-Z1 single-zone processing board, for stand-alone systems;
2. SC-SMCAPF-CTRL + SC-SMCAPF-PU + SC-ER8 modular system, which manages up to 24 zones. Each sensor-module is connected to an SC-SMCAPF-PU interface board, which is in turn connected to SC-SMCAPF-CTRL by means of SCA NET bus. SC-SMCAPF-CTRL can be connected up to three SC-ER8 expansion boards, each of them providing 8 configurable relays.

SOLUTION 1: EACH BR-SMCA-Z1 BOARD MANAGES ONE SENSOR-MODULE

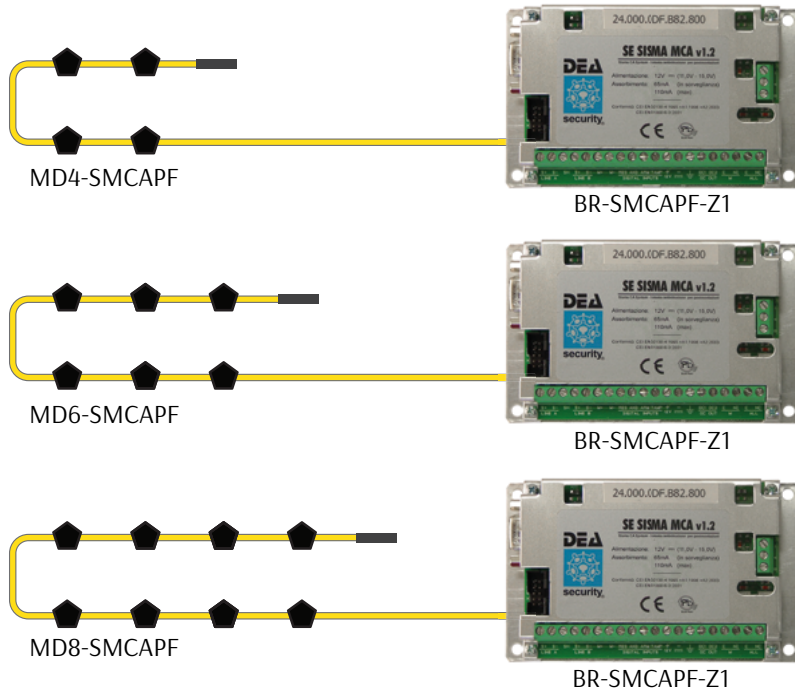

SOLUTION 2: SC-SMCAPF-PU BOARDS (UP TO 24) COMMUNICATE WITH BR-XS-CTRL32/64 BOARD BY MEANS OF SMCA NET

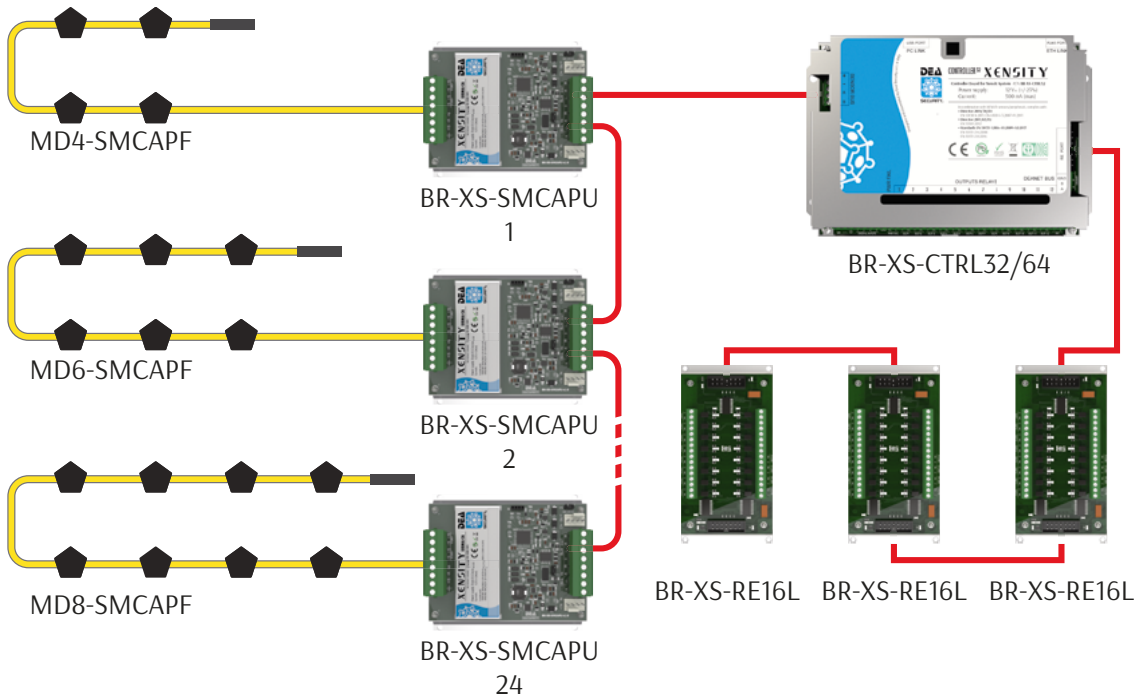

- **PROTECTION OF RAISED FLOOR:**
 - no. 4 sensor-modules model MD4-SMCA PF (6 m²);
 - no. 3 sensor-modules model MD6-SMCA PF (9 m²);
- **CENTRALIZATION SYSTEM:**
 - no. 1 centralization cabinet (Box0) containing the centralization board and the interface boards.

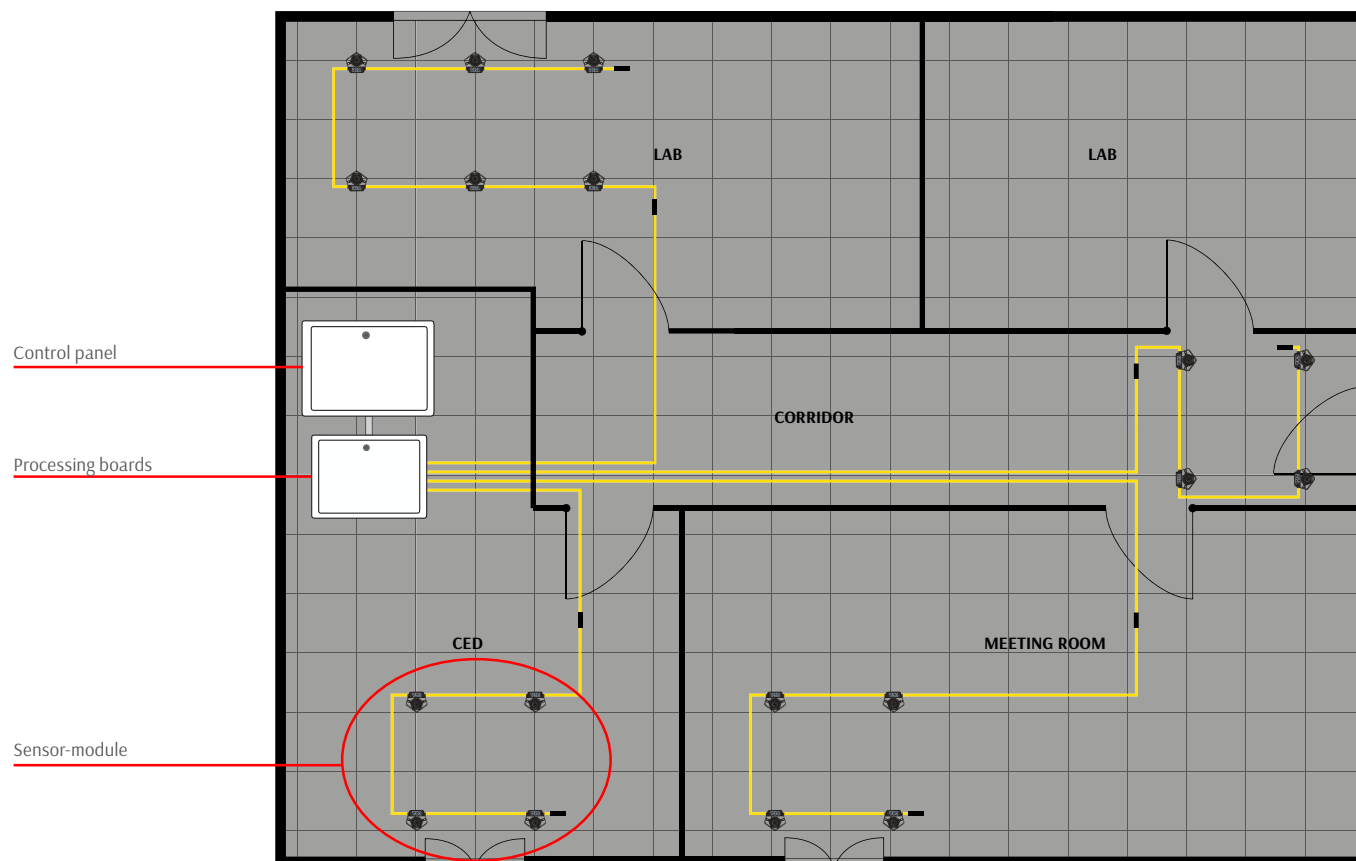

LIST OF PARTS TO MAKE A SYSTEM AS PER THE ABOVE EXAMPLE:

Sensor-modules, connection cable and wiring accessories

Q.TY	PART NUMBER	DESCRIPTION
3	MD4-SMCA PF	Sensor-module for the protection of 6 m ²
1	MD6-SMCA PF	Sensor-module for the protection of 9 m ²
1	CV-SMCA-50	Connection cable between the sensor-module and processing boards
4	JBX-SMCA	Junction case
4	RP-100	Two-component PUR cast resin to seal junction and termination cases

Cabinet Box1 and relevant processing boards

Q.TY	PART NUMBER	DESCRIPTION
1	AP-2C	Preassembled polyester cabinet
1	AL-20	Microprocessor stabilized linear power supply unit 2.5A - 13.8 Vdc
4	BR-SMCA-Z1	Single-zone processing board

OUTDOOR SYSTEMS

DEA NET

COMMUNICATION SYSTEM

DA NET is an ecosystem of technologies and devices which allow DEA systems to centralize and manage remote signals (alarm, tamper and fail) over proprietary network protocol (DEA NET) and/or Ethernet (TCP/IP).

DEA NET also allows integrating DEA's solutions with a wide range of third-party products, among which the most popular third-party VMS and PSIM software.

CONTROLLER BOARD FOR ETHERNET NETWORK

PART NUMBER

BR-DN-ETHCTRL



The electronic controller board for Ethernet network manages up to 16 DEA Security electronic analysis boards. It checks the operating status of each single board and collects the related signals, saving the latter to an internal memory and make them available through dry contacts, over DEA NET proprietary network or over IP network. The service software allows monitoring and configuring, locally or remotely, all the analysis boards and the relais expansion boards (if any) connected.

COMPLIANCE

- **Directive 2014/30/EU (EMC)**
 - EN 50130-4:2011
 - EN 61000-6-3:2007+A1:2011
- **Directive 2011/65/EU (RoHS)**
 - EN 50581:2012

TECHNICAL FEATURES

- **Dimensions:** 178 x 116 x 30 mm (W x H x D)
- **Packaging dimensions:** 235 x 170 x 70 mm (W x H x D)
- **Gross weight:** 604 g
- **Net weight:** 302 g
- **Power supply:** 12 Vdc (+/- 25%)
- **Current:** 0.5 A (max)
- **Operating temperature:** -25 ÷ +70 °C
- **Relative humidity:** <95% non condensing
- **Management capability:** up to 16 electronic boards
- **Inputs:** 4 digital opto-isolated
- **NC relay outputs (positive security):**
 - general intrusion alarm
 - general tamper
 - Low supply voltage/Service Active/No Operating Software
 - link loss
 - 9 programmable
- **Auxiliary C/NC relay outputs:** up to 128 with 4 BR-XS-RE16L boards (via flat) and 4 BR-DN-RE16 boards (on DEA NET bus)
- **OC outputs :** 2 programmable
- **Communication port:**
 - USB (PC link)
 - Ethernet
 - DEA NET bus
 - connector for flat cable
- **Calibration, settings and event management via service**
- **CPU:** 32 bit
- **Digital memory:** more than 20.000 events
- **Service software licence included**



The controller board must be installed inside an open-proof case.

DEA NET

PART NUMBER	DESCRIPTION
BR-DN-ETHCTRL	Controller board with Ethernet interface

SERVER BOARD FOR ETHERNET NETWORKS

PART NUMBER

SC-DN-ETHSRV



Network server which allows centralizing and managing up to 8 controller boards or analysis units equipped with Ethernet port. The boards which are currently compatible with the network server are SC-ETHCTRL network controller, SERIR P2P BR-SRP2P-CTRL, XENSITY BR-XS-CTRL32 and BR-XS-CTRL64 controllers. To the server can be also connected up to 16 BR-DN-RE16 local relay expansion boards.

The main use of SC-DN-ETHSRV is collecting alarm, tamper and fail signals from the controllers connected to it via IP network to make them available on remote NC relay contacts (up to 256) which can be configured by means of the service software provided with the server.

COMPLIANCE

- **Directive 2014/30/EU (EMC)**
 - EN 50130-4:2011+A1:2014
 - EN 61000-6-3:2007+A1:2011
- **Directive 2011/65/EU (RoHS)**
 - EN 50581:2012

TECHNICAL FEATURES

- **Dimensions:** 200 x 130 x 39 mm (W x H x D)
- **Packaging dimensions:** 280 x 160 x 70 mm (W x H x D)
- **Gross weight:** 600 g
- **Net weight:** 438 g
- **Power supply:** 12 Vdc (+/- 25%)
- **Current:** 300 mA (max)
- **Operating temperature:** -25 ÷ +80 °C
- **Relative humidity:** <95% non condensing
- **Management capability:**
 - up to 8 boards with Ethernet port
 - up to 15 BR-DN-RE16 relay expansion boards
- **Digital inputs:** 8 software programmable
- **NC relay outputs (positive security):**
 - Low supply voltage/Service Active/No Operating Software
 - general intrusion alarm
 - general tamper
 - IP board link loss
 - general fail
 - up to 256 external relays on expansion boards
- **OC outputs /NC:** 3 programmable
- **Communication port:**
 - relay expansion bus (BR-DN-RE16)
 - USB for service
 - Ethernet for service and for connection to IP boards
- **Calibration, settings and event management via software**
- **CPU:** 32 bit, 168 MHz
- **Digital memory:** more than 20.000 events
- **Service software licence included**

PART NUMBER	DESCRIPTION
SC-DN-ETHSRV	Centralization board for IP networks

INTERCONNECTION BOARD

PART NUMBER
SC-DN-HTRPT

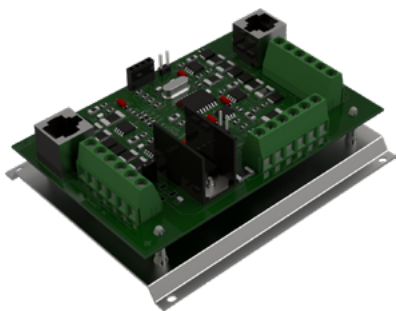

Interconnection board which connects DEA Security processing boards to DEA NET. This board amplifies and regenerates the signals over DEA NET, making it possible to cover long distances.

COMPLIANCE

IF CONNECTED TO BR-DN-ETHCTRL:

- **Directive 2014/30/EU (EMC)**
 - EN 50130-4:2011+A1:2014
 - EN 61000-6-3:2007+A1:2011
- **Directive 2011/65/EU (RoHS)**
 - EN 50581:2012

TECHNICAL FEATURES

- **Dimensions:** 104 x 96 x 37 mm (W x H x D)
- **Packaging dimensions:** 130 x 100 x 55 mm (W x H x D)
- **Gross weight:** 235 g
- **Power supply:** 12 Vdc (+/- 25%)
- **Current:** 60 mA
- **Operating temperature:** -25 ÷ +70 °C
- **Relative humidity:** <95% non condensing
- **Output for DEA NET bus (through terminal board)**
- **Connections to DEA NET (by means of RJ45 connector or through terminal board)**
- **No. of devices managed on bus DEA NET:** up to 16 boards (BR-FSP2P-CTRL, BR-SRP2P-CTRL, BR-SR50-Z2, BR-SR50-Z4, BR-TR50-Z2, BR-TR50-Z4, BR-SMCP50-Z1, BR-SMCP50-Z2, BR-SMCA-Z1, SC-SMCA-CTRL, SC-SMCA-PF-CTRL, SC-DN-IO, SC-DN-IOLP, BR-DN-RE16, AL-DN-DEAPW)

DEA NET

PART NUMBER	DESCRIPTION
SC-DN-HTRPT	Interconnection board

INTERCONNECTION BOARD WITH HIGH INSULATION

PART NUMBER

SN-DN-HTRPTAS



High-insulation version of SC-DN-HTRPT board to be used in environments highly disturbed by electromagnetic inductions. The three ports on the board are galvanically isolated (with isolation voltage up to 2500 VRMS), guaranteeing a high immunity to possible environmental disturbances along the communication line.

COMPLIANCE

IF CONNECTED TO BR-DN-ETHCTRL:

- **Directive 2014/30/EU (EMC)**
 - EN 50130-4:2011+A1:2014
 - EN 61000-6-3:2007+A1:2011
- **Directive 2011/65/EU (RoHS)**
 - EN 50581:2012

TECHNICAL FEATURES

- **Board dimensions:** 127 x 85 mm (B x H)
- **Mounting plate dimensions:** 147 x 89 mm (B x H)
- **Power supply:** 12 Vdc (+/- 25%)
- **Current:** 135 mA
- **Operating temperature:** -25 ÷ +70 °C
- **Relative humidity:** <95% non condensing
- **Output for DEA NET bus (through terminal board) galvanically isolated up to 2500 VRMS**
- **Connections to DEA NET (by means of RJ45 connector or through terminal board) galvanically isolated up to 2500 VRMS**
- **No. of devices managed on bus DEA NET:** up to 16 boards (BR-FSP2P-CTRL, BR-SRP2P-CTRL, BR-SR50-Z2, BR-SR50-Z4, BR-TR50-Z2, BR-TR50-Z4, BR-SMCP50-Z1, BR-SMCP50-Z2, BR-SMCA-Z1, SC-SMCA-CTRL, SC-SMCA-PF-CTRL, SC-DN-IO, SC-DN-IOLP, BR-DN-RE16, AL-DN-DEAPW)

DEA NET

PART NUMBER	DESCRIPTION
SC-DN-HTRPTAS	Interconnection board with 2kV insulation



Interface board which allows sending over DEA NET the signals generated by third-party equipment. It has 4 triple balanced analog inputs, 4 digital inputs and 2 relay outputs for the activation of third party devices.

COMPLIANCE

- **Directive 2014/30/EU (EMC)**
 - EN 50130-4:2011+A1:2014
 - EN 61000-6-3:2007+A1:2011
- **Directive 2011/65/EU (RoHS)**
 - EN 50581:2012

TECHNICAL FEATURES

- **Dimensions:** 133 x 80 x 24 mm (W x H x D)
- **Packaging dimensions:** 165 x 90 x 65 mm (W x H x D)
- **Gross weight:** 247 g
- **Power supply:** 12 Vdc (+/- 25%)
- **Current:** 60 mA (stand-by) - 80 mA (max)
- **Operating temperature:** -25 ÷ +80 °C
- **Relative humidity:** <95% non condensing
- **Inputs:**
 - 4 triple balanced analog (alarm, tamper, cable cut)
 - 4 programmable digital
- **OC outputs (negative):** mains loss 230 V
- **Relay outputs:** 2 configurable
- **Communication port:**
 - DEA NET bus
 - RS-232 (PC link)
- **Calibration and settings via software**
- **CPU:** 16 bit, 168 MHz
- **Service software licence included**

PART NUMBER	DESCRIPTION
SC-DN-IO	Input/output board

INPUT/OUTPUT BOARD WITH PROGRAMMABLE LOGIC

PART NUMBER

SC-DN-IOLP



Programmable logic input/output board which allows transmitting over DEA NET relay signals generated by third-party equipment. The logic functions can be customized by means of special tool software based on the Ladder Logic graphical standard.

COMPLIANCE

- **Directive 2014/30/EU (EMC)**
 - EN 50130-4:2011+A1:2014
 - EN 61000-6-3:2007+A1:2011
- **Directive 2011/65/EU (RoHS)**
 - EN 50581:2012

TECHNICAL FEATURES

- **Board dimensions:** 113 x 78 mm (B x H)
- **Mounting plate dimensions:** 133 x 80 mm (B x H)
- **Power supply:** 12 Vdc (+/- 25%)
- **Current:** 60 mA (stand-by) – 80 mA (max)
- **Operating temperature:** -25 ÷ +80 °C
- **Relative humidity:** <95% non condensing
- **Inputs:**
 - 4 triple balanced analog (alarm, tamper, cable cut)
 - 4 programmable digital
- **Virtual inputs:** up to 4 signals configurable from DEA NET
- **Virtual outputs:** up to 4 over DEA NET
- **Relay outputs:** 2 configurable
- **Communication port:**
 - DEA NET bus
 - RS-232 (PC link)
- **Calibration and settings via software**
- **CPU:** 16 bit, 16 MHz
- **Service software licence included**
- **Ladder Logic Programming software licence included**

DEA NET

PART NUMBER	DESCRIPTION
SC-DN-IOLP	Input/output board with programmable logic

16-RELAY EXPANSION BOARD

PART NUMBER
BR-DN-RE16

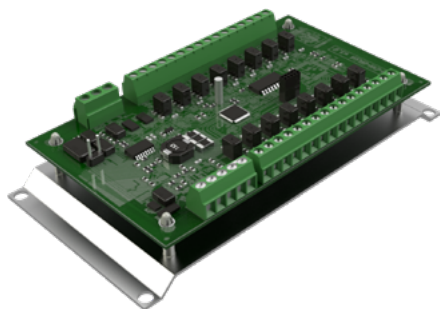

16-relay expansion board to transfer the signals coming from DEA NET to C/NC/NO contacts.

It provides relays outputs which can be configured via BR-DN-ETHCTRL, SC-DN-ETHSRV, BR-FSP2P-CTRL or BR-SRP2P-CTRL software.

COMPLIANCE

IF CONNECTED TO BR-DN-ETHCTRL, SC-DN-ETHSRV, BR-FSP2P-CTRL AND BR-SRP2P-CTRL:

- **Directive 2014/30/EU (EMC)**
 - › EN 50130-4:2011+A1:2014
 - › EN 61000-6-3:2021
- **Directive 2011/65/EU (RoHS)**
 - › EN 50581:2012

TECHNICAL FEATURES

- **Dimensions:** 130 x 64 x 29 mm (W x H x D)
- **Packaging dimensions:** 145 x 70 x 67 mm (W x H x D)
- **Gross weight:** 122 g
- **Net weight:** 74 g
- **Power supply:** 12 Vdc (+/- 25%)
- **Current:** 50 mA (stand-by) – 220 mA (max)
- **Max Output Rating (ac/dc):** 30V (Load voltage)/0,5A (Load current)
- **Operating temperature:** -25 ÷ +80 °C
- **Relative humidity:** <95% non condensing
- **Relay outputs:**
 - low supply voltage/board operating anomalies, DEA NET bus link loss
 - 16 configurable relays
- **Connections:** DEA NET bus
- **CPU:** 32 bit, 32 MHz

PART NUMBER	DESCRIPTION
BR-DN-RE16	16-relay expansion board

1-RELAY EXPANSION BOARD

PART NUMBER
SC-ER1

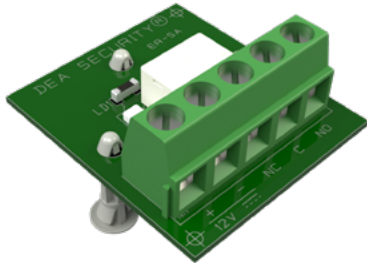

1-relay expansion board to convert OC outputs into C/NC/NO contacts.

COMPLIANCE

IF CONNECTED TO BOARDS WHICH PROVIDE FOR ITS USE:

- Directive 2014/30/EU (EMC)

TECHNICAL FEATURES

- **Dimensions:** 36 x 32 x 31 mm (W x H x D)
- **Gross weight:** 13 g
- **Power supply:** 12 Vdc (+/- 25%)
- **Current:** 12 mA
- **Operating temperature:** -25 ÷ +80 °C
- **Relative humidity:** <95% non condensing
- **Input:** 1 per OC signal
- **NC relay outputs (1 A):** C/NC/NO

PART NUMBER	DESCRIPTION
SC-ER1	1-relay expansion board (OC into C/NC/NO)



Microprocessor stabilized linear power supply unit. It sends the critical information about the supply of the system to DEA NET, making it possible to monitor these data from remote station.

COMPLIANCE

- **Directive 2014/30/EU (EMC)**
 - EN 50130-4:2011+A1:2014
 - EN 61000-6-3:2007+A1:2011
- **Directive 2011/65/EU (RoHS)**
 - EN 50581:2012
- **Directive 2014/35/EU (LDV)**
 - EN 62368-1:2014+A11:2017

TECHNICAL FEATURES

- **Dimensions:** 99 x 122 x 195 mm (W x H x D)
- **Packaging dimensions:** 220 x 135 x 135 mm (W x H x D)
- **Gross weight:** 1.5 Kg
- **Nominal input voltage:** 230 Vac (+/-10% - 50 Hz)
- **Max current consumption:** 170 mA (230 Vac)
- **Stabilized output voltage:** 13.8 V stabilized (12 V nominal)
- **Max output current:** 2.5 A
- **Max ripple:** <20 mV
- **Protection over battery:** 14 Vdc
- **Current to recharge:** 0.5 A (12 V, 2 Ah battery)
- **Operating temperature:** -25 ÷ +80 °C
- **Relative humidity:** <95% non condensing
- **Nominal input voltage:** phase, neutral, earth
- **Digital inputs:** 4 programmable
- **Power outputs:**
 - Vout = 13.8 Vdc (12 V nominal) protected by fuse F02
 - Batt = 13.8 Vdc protected by fuse F03
- **OC outputs (negative):** mains loss 230 Vac
- **Communication port:**
 - DEA NET bus
 - RS-232 (PC link)
- **Calibration, settings and event management via software**
- **CPU:** 8 MHz, 60 kB flash, 2 kB RAM
- **Digital memory:** 128 kbit flash memory
- **Service software licence included**

PART NUMBER	DESCRIPTION	CURRENT	BATTERY CAPACITY
AL-DN-DEAPW	Microprocessor stabilized linear power supply unit	2.5 A	24 Ah

APPLICATION EXAMPLES

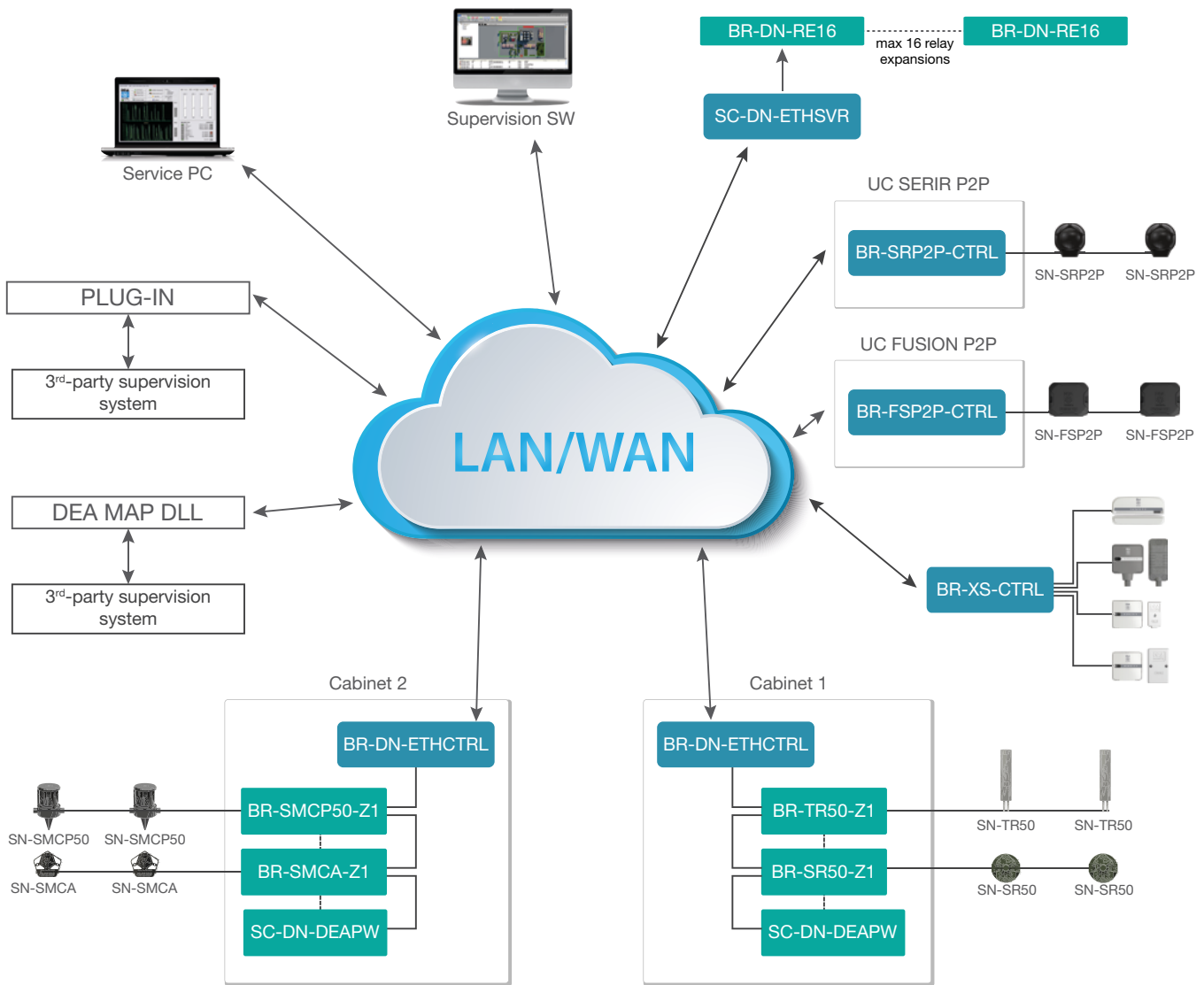

BUS TOPOLOGY

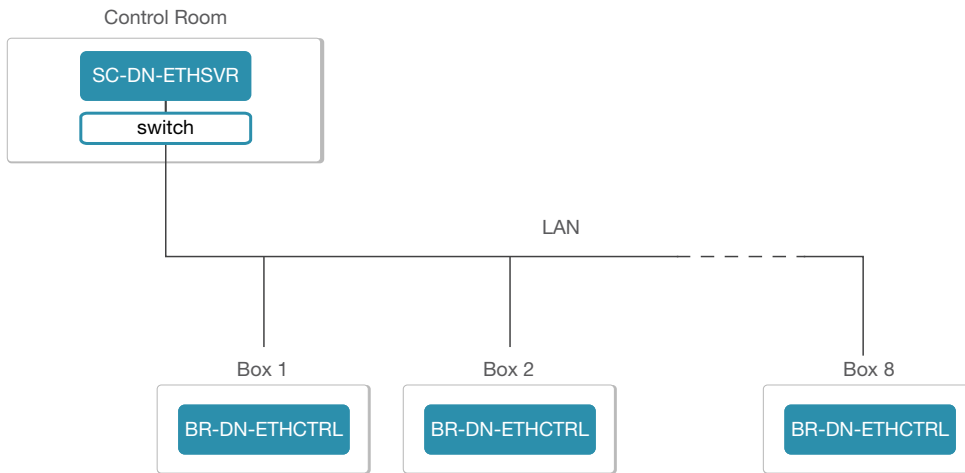

STAR TOPOLOGY

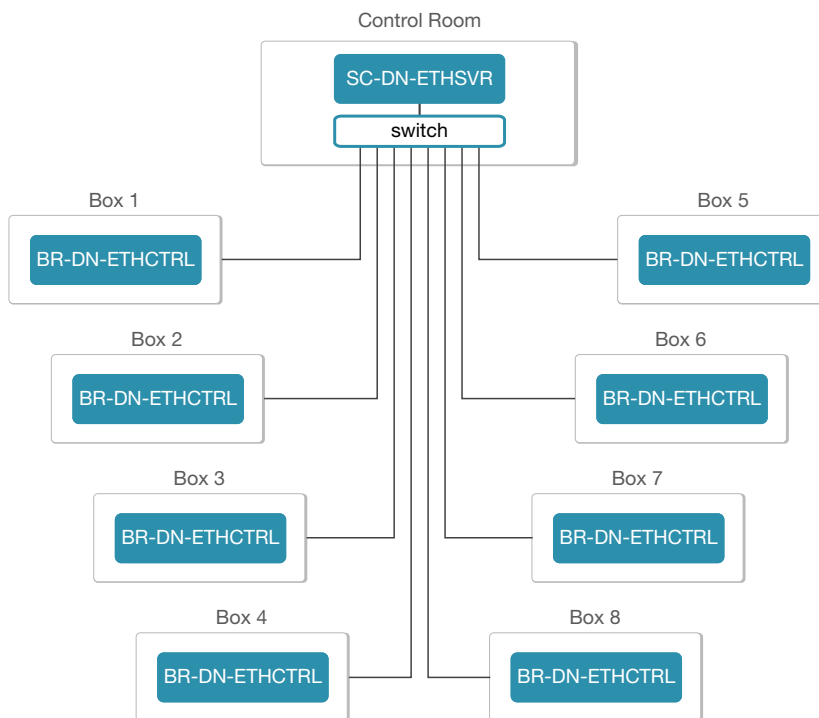

SOFTWARE

APPLICATIONS AND PLUG-INS

Software for the centralization, management and/or integration of DEA Security's systems over network.

DEA MAP DLL

PART NUMBER
SW-DM-DLL

Dynamic library which allows integrating the signals coming from BR-SRP2P-CTRL and/or BR-DN-ETHCTRL into a third-party software.

PART NUMBER	DESCRIPTION
SW-DM-DLL	DEA MAP DLL dynamic library software licence

ETHERNET SHARER

PART NUMBER
SW-ETHSHR

ETHERNET SHARER software allows creating and managing a network with BR-DN-ETHCTRLs connected to each other over Ethernet. Thanks to it, all the relays of the boards connected to BR-DN-ETHCTRL controllers can be also shared and managed by the other BR-DN-ETHCTRL controllers over the same network.

MINIMUM REQUIREMENTS

- Dual-core processor at 1.8 GHz or superior
- 3 GB RAM
- HDD \geq 250 GB
- DirectX 10.1 videocard with 128 MB memory minimum
- 1024 x 768 pixel resolution monitor or higher
- 10/100 Base/T Ethernet card
- Keyboard
- Mouse
- Operating systems supported: Microsoft Windows XP and the following
- UPS



There is no theoretical limit to the number of BR-DN-ETHCTRLs which can be managed by the ETHERNET SHARER software, however we suggest not exceeding 32 unit to avoid network traffic congestion.

PART NUMBER	DESCRIPTION
SW-ETHSHR	ETHERNET SHARER software licence

PLUG-IN FOR THE INTEGRATION WITH MILESTONE XPROTECT

PART NUMBER
SW-PLG-MLS

SW-PLG-MLS plug-in allows integrating DEA Security perimeter intrusion systems with Milestone Xprotect VMS. By means of an IP protocol, this plug-in communicates with XProtect and makes alarm, tamper and fail events generated by DEA Security's systems available on this software. It also allows the direct management of the status of the protected zones.



A license key provided by DEA Security is required to use SW-PLG-MLS.

PART NUMBER	DESCRIPTION
SW-PLG-MLS	Plug-in for the integration with Milestone XProtect

ACCESSORIES

SELF-LOCKING TIE-WRAPPS

PART NUMBER
FPA-150



Polyamide tie-wraps with locking device, UV resistant. The FPA-150 tie-wraps are provided in 100-piece packs.

COMPLIANCE

- HF
- cURus
- ANSI/UL 1565, ANSI/UL 62275
- EN 62275
- Directive 2011/65/EU (RoHS)
 - EN 50581:2012

TECHNICAL FEATURES

- **Dimensions:** 150 x 3.5 mm (length x width)
- **Material:** UV-resistant polyamide 6.6 (PA66W)
- **Colour:** black
- **Operating temperature:** -40 ÷ +85 °C (+105 °C, 500 h)



One pack of FPA-150 tie-wraps can fix approx. 25 metres of FUSION P2P, SERIR P2P, SERIR 50, SERIR COMPACT 50, TORSUS 50 or TORSUS COMPACT 50 sensor-strings.

PART NUMBER	DESCRIPTION	PACKAGE	DIMENSIONS
FPA-150	Self-locking tie-wraps	100 pezzi	150 x 3.5 mm

RESIN FOR JUNCTIONS/TERMINATIONS

PART NUMBER
RP



Hard two-component PUR cast resin for electrical use. It hardens at room temperature.



One pack of resin seals two JBX-P2P, TBX-P2P or JTBX-ST50 cases or one SC-P2P-IN1, JBX-SMCP50-ILT, JBX-SMCP50, TBX-SMCP50, JBX-SMCA, TBX-SMCA, TBX-SMCAPF case.

PART NUMBER	DESCRIPTION
RP-100	100ml PUR cast resin for junction/termination cases

STABILIZED POWER SUPPLY UNIT FOR CU-FSP2P

PART NUMBER

AL-P2P-3024



Stabilized switching power supply unit (mark Adelsystem) with 24 Vdc output voltage and 3 A max output current. It provides two relay outputs: one for mains or backup and one for low or discharged battery.

COMPLIANCE

- Directive 2006/95/CE
- Directive 89/336/CEE
- EN 60950, EN 60335-2-29, EN 54-4, EN 60529 (IP20)
- IEC 61000-6-4, IEC 61000-6-2
- DIN 41773
- UL 1950

TECHNICAL FEATURES

- **Nominal input voltage:** 115 – 230 Vac
- **Input frequency:** 47 ÷ 63 Hz
- **Current:** 1.3 A (max) 230 Vac
- **Stabilized output voltage:** 24 Vdc
- **Max output current:** 3 A
- **Operating temperature:** -25 ÷ +70 °C
- **Relative humidity:** <95% non condensing
- **Dimensions:** 65 x 115 x 135 mm (W x H x D)
- **SPDT relay outputs (max 30 Vdc 1 A - max 60 Vac 1 A):**
 - discharged or damaged battery
 - power from mains or from backup

FUSION P2P

PART NUMBER	DESCRIPTION
AL-P2P-3024	Stabilized power supply unit for CU-FSP2P

STABILIZED LINEAR POWER SUPPLY UNITS

PART NUMBER

AL



Linear regulated power supply unit (brand Venitem) equipped with toroidal transformer, suitable for charging a buffer battery.

COMPLIANCE

- **Directive 2014/30/EU (EMC)**
 - EN 55032:2015
 - EN 61000-3-2:2019
 - EN 61000-3-3:2013
- **Directive 2014/35/EU (LVD)**
 - EN 62368-1:2018
- **Directive 2011/65/EU (RoHS)**
 - EN 50581:2012

TECHNICAL FEATURES

- **Power supply:** 230 Vac
- **Current:**
 - 279 mA (AL-20)
 - 530 mA (AL-30)
- **Operating temperature:** -10 ÷ +40 °C
- **Dimensions:**
 - 70 x 104 x 160 mm (W x H x D - AL-20)
 - 75 x 116 x 192 mm (W x H x D - AL-30)
- **Max output current (dc):**
 - 2 A (AL-20)
 - 3 A (AL-30)
- **Max battery capacity:**
 - 17 Ah (AL-20)
 - 24 Ah (AL-30)
- **Auxiliary outputs:**
 - 19 Vac max 200 mA
 - 230 Vac mains presence

Stabilized linear power supplies are available in the following versions:

PART NUMBER	DESCRIPTION	CURRENT	BATTERY CAPACITY
AL-20	Stabilized linear power supply unit	2 A	17 Ah
AL-30	Stabilized linear power supply unit	3 A	24 Ah

BACKUP BATTERY FOR CU-FSP2P

PART NUMBER
BT-P2P-12V



12 V rechargeable lead-acid backup battery. The 24 V battery pack included inside the Control Unit contains two BT-P2P-12V batteries.

TECHNICAL FEATURES

- **Nominal voltage:** 12 V
- **Capacity:** 7.2 Ah
- **Dimensions:** 151 x 94 x 64.5 mm (W x H x D)

PART NUMBER	DESCRIPTION
BT-P2P-12V	Backup battery for CU-FSP2P

BACKUP BATTERY FOR COMPACT SYSTEMS

PART NUMBER
BT-C12



12 V rechargeable lead acid backup battery operating during mains failure or interruptions.

TECHNICAL FEATURES

- **Dimensions:** 42 x 95 x 55 mm (W x H x D)
- **Capacity:** 1.2 Ah
- **Nominal voltage:** 12 V

PART NUMBER	DESCRIPTION
BT-C12	Backup battery for COMPACT systems

CABINET FOR CU-FSP2P

PART NUMBER
BOX-P2P

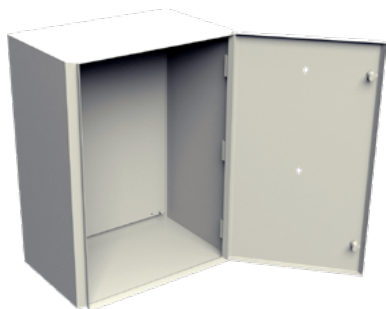

Polyester cabinet for outdoor use in which the components of the Control Unit are assembled.

COMPLIANCE

- IEC 62208, IEC 60695-2-10, IEC 60695-2-11, IEC 60695-11-5
- IP66 (IEC 62208)
- IK-10 (IEC 62208)

TECHNICAL FEATURES

- **Dimensions:** 300 x 400 x 200 mm (W x H x D)
- **Weight (including backplate):** approx. 5 Kg
- **Material:** glass fiber reinforced polyester, self-extinguishing
- **Insulation:** double, halogen-free
- **Termical class:** 105
- **IP rating:** IP66
- **Operating temperature:** -30 ÷ +70 °C

PART NUMBER	DESCRIPTION
BOX-P2P	Polyester cabinet for CU-FSP2P

CABINET FOR COMPACT SYSTEMS

PART NUMBER
BOX-C50



Polyester cabinet for outdoor use to assemble the electronic components forming the Analysis Unit.

COMPLIANCE

- **Directive 2014/30/EU (EMC)**
 - EN 50130-4:2011+A1:2014
 - EN 61000-6-3:2007+A1:2011
- IEC 62208, IEC 60695-2-10, IEC 60695-2-11, IEC 60695-11-5

TECHNICAL FEATURES

- **Dimensions:** 200 x 254 x 135 mm (W x H x D)
- **Operating temperature:** -30 ÷ +70 °C
- **Material:** glass fiber reinforced polyester, self-extinguishing
- **IP rating:** IP55 (IP44 with ventilation openings)
- **Insulation:** double, halogen-free
- **Weight (including backplate):** approx. 1.5 Kg

PART NUMBER	DESCRIPTION
BOX-C50	Polyester cabinet for COMPACT systems



Polyester cabinets, factory-assembled according to the project specifications. They provide inputs and outputs on DIN rail terminal board and integrate a shock detector to signal forcing and breaking-through.

BASIC EQUIPMENT:

- Safety locks
- Mounting plate
- Mounting brackets
- Tamper switch
- Shock sensor
- Circuit breaker
- 230 V socket
- Schematics
- Terminal board wiring diagram

COMPLIANCE

- IEC 62208, IEC 62262, IEC 60439-1, IEC 60439-5, IEC 60695-2, IEC 60670
- EN 60529 (IP44), EN 62262 (IK10), EN 60085 (105)

TECHNICAL FEATURES

- **Dimensions:** please see the table below
- **Weight:** n.d. (it depends on the configuration of the system)
- **Operating temperature:** -30 ÷ +70 °C
- **Material:** glass fiber reinforced polyester, self-extinguishing
- **IP ratings:** IP66 (IP44 with ventilation openings), IK10 (flat cable supplied with the board)
- **Insulation:** double, halogen-free
- **Termical class:** 105
- **Detector:** seismic sensor with piezodynamic transducer and integrated electronics; it detects shock and breakthrough events

Quotations for non-standard cabinets can be provided on demand.

PART NUMBER	DESCRIPTION	DIMENSIONS (W x H x D)
AP-1C	Preassembled polyester cabinet	400 x 500 x 200 mm
AP-2C	Preassembled polyester cabinet	400 x 600 x 230 mm
AP-3C	Preassembled polyester cabinet	500 x 600 x 230 mm
AP-4C	Preassembled polyester cabinet	600 x 800 x 300 mm
AP-5C	Preassembled polyester cabinet	800 x 1.060 x 350 mm

POLE MOUNT KIT FOR BOX-P2P CABINETS

PART NUMBER

CL-BOXP2P



Kit to mount the BOX-P2P cabinet to the poles. It includes two metal straps 125 cm long, two brackets and the relevant mounting hardware.

PART NUMBER	DESCRIPTION
CL-BOXP2P	Pole mount kit for BOX-P2P cabinet

POLE MOUNT KIT FOR AP-C CABINETS

PART NUMBER

CL-AP

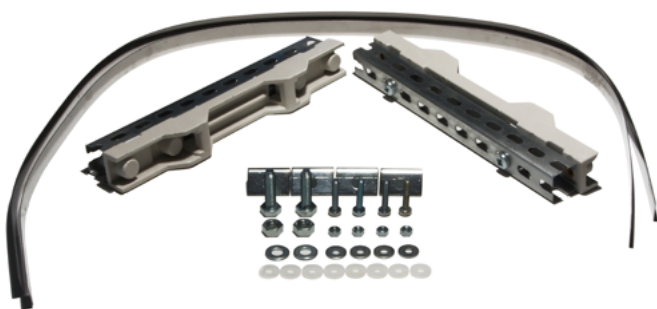

Kit to mount the AP-1C, AP-2C, AP-3C and AP-4C cabinets to the poles. It includes two metal straps 125 cm long, two brackets and the relevant mounting hardware.

PART NUMBER	DESCRIPTION
CL-AP1	Pole mount kit for AP-1C cabinets
CL-AP2	Pole mount kit for AP-2C cabinets
CL-AP3	Pole mount kit for AP-3C cabinets
CL-AP4	Pole mount kit for AP-4C cabinets

INSTRUCTIONS - INDOOR SYSTEMS

DEA Security indoor perimeter intrusion detection systems consist of a wide range of shock sensors for the protection of doors, windows, glass doors and windows, burglar bars, walls and other types of structures.

The detectors perceive the shocks (single or repeated) and the vibrations due to an attack to the physical barrier to which they are installed (for example a door or a window) following an intrusion attempt, either real or simulated.

Thanks to sophisticated analysis algorithms, DEA Security indoor systems offer a very high tolerance to environmental nuisances and superior detection capability.

The operating parameters of the system can be set by the professional installer which can choose the desired protection level. As a matter of fact, the installer can adjust the sensitivity and the detection capability (event number, reset time etc.) for each type of attack in order to obtain the best performance on the specific protected structure/surface.

The detection capability of each system depends not only on the calibration set but also on the installation conditions. As a matter of fact the performance of the sensors varies according to the dimensions, the thickness and the material of the protected surface/structure. For this reason you should always check the correct functioning of the system by simulating the impacts which are to be detected and by adjusting the sensitivity and the security level of each single sensor accordingly.

The detection capability of the system can be set by the professional installer up to very high levels in order to perceive and detect very sophisticated attack methods which are carried out with great care.

To its maximum sensitivity the capability of the system to discriminate environmental nuisances may however decrease and consequently improper alarms may be triggered following to impacts or vibrations not due to a real intrusion attempt and also occurred outside of the protected area.

INSTRUCTIONS - OUTDOOR SYSTEMS

TOLERANCE TO ANIMALS

Although DEA Security outdoor perimeter intrusion detection systems tolerate the presence of small animals, under certain circumstances the latter might stress the detection system up to raising an alarm. In case of domestic animals of medium or big size (such as dogs), these shall be kept away from the perimeter intrusion detection systems.

If SISMA CP and SISMA CA systems are chosen, DEA Security strongly advise you to install them inside enclosed sites where the presence of wild animals is unusual.

IMMUNITY AND DETECTION CAPABILITY

Thanks to their sophisticated electronics, DEA Security systems have a high tolerance to environmental disturbances and at the same time a very good detection capability.

These systems may, however, be stressed by persons "simulating an intrusion" (hitting the fence protected with SERIR and/or TORSUS system or climbing it, crossing a terrain or a floored area respectively protected with SISMA CP and SISMA CA systems).

Of course in these cases you cannot discriminate a simulation from a real intrusion attempt and the system will correctly signal the event detected as an "alarm event".

FUSION, SERIR and TORSUS systems cannot guarantee the detection of cuts carried out by using oxyhydrogen flame and the like or when no shock or sudden movement of the fence occurs.

COMPATIBLE FENCING AND FUNCTIONING OF FUSION, SERIR AND TORSUS SYSTEMS

FUSION and SERIR protects rolled metal fences (welded or chainlink) against cut, climb and breakthrough.

If possible, a welded mesh fence should be preferred because it favours a more effective cut detection; however, if a chainlink fence is present, you have to make sure it is well-taut. The wire of the meshes (both welded and chainlink) must have a diameter of not less than 3 mm.

FUSION and TORSUS protects the rigid metal fences against shock, climb and breakthrough. Under this category we find both hand-made and industrial fences made up of a sequence of panels supported by posts.

Due to a wide range of rigid fences on the market, it could be necessary to assess the feasibility of a TORSUS system by carrying out an on-site survey performed by a professional installer qualified to install DEA Security products.

To represent an adequate physical barrier and make SERIR and TORSUS systems work with the utmost efficiency, the overall height of the fence must not be less than 2.5 m.

DISTURBING ELEMENTS FOR FUSION, SERIR AND TORSUS SYSTEMS

FUSION, SERIR and TORSUS systems are not compatible with fences covered with woven screening nets: in case of strong wind those nets stress the fences in an anomalous way and can raise improper alarms.

For further information, please see the relevant "Installation Technical Manuals".

DISTURBING ELEMENTS FOR SISMA CP BURIED SYSTEM

Before installing a Sisma CP detection system, you have to make sure that no disturbing element such as trees, big posts, pressure water tubes or irrigation systems, roads and railways is present within a certain distance from the sensor strings.

For further information, please see "SISMA CP Installation Technical Manual".

FLOORING COMPATIBLE WITH SISMA CA SYSTEM

SISMA CA system consists of special pressure sensors to be integrated into the concrete screed of the flooring. These detectors have to be set on an armoured concrete slab, to which they will be fixed with the cement based adhesive supplied with them and then they have to be covered with concrete (screed) of about 8-cm thickness.

However, the thickness of the screed depends on the type of flooring used (tiles, porphyry, stone slabs, etc.).

For technical details, please see "SISMA CA Installation Technical Manual".

MANAGEMENT SYSTEM

DEA Security perimeter intrusion detection systems need a management system typically represented by a control panel and accessories such as keyboards, electronic keys, sirens, telephone dials, etc. This equipment has to be estimated, supplied and configured by the installation company. The latter has to make sure that the alarm system can collect (as far as the type and the number are concerned) the signals from DEA Security outdoor perimeter intrusion detection systems.

The signals are available through non-polarized NC relay contacts or through OC outputs into NC relay contacts. Such a standard guarantees the compatibility with any control panel.

In case of systems over DEA NET, a dynamic library licence (DLL) for Microsoft Windows® environment is available and can be interrogated by third-party software.

DEA Security s.r.l. address to professional customers selected according to purely qualitative criteria, namely to installers and system integrators working in the intrusion security industry mainly.

Those companies must: a) in DEA Security' judgement, have a good experience in installing DEA Security products or b) have attended the technical training course that DEA Security arrange at their facility in Santo Stefano di Magra (La Spezia - Italy) to show them the procedures to install, manage and configure DEA Security products.

The above companies make projects, assemble the several components present on the market and install the same at the end user's, taking care of the technical assistance and the maintenance service during the warranty and the post warranty period; therefore they purchase DEA Security products to sell them (and also install them) to the end user.

The products marketed by DEA Security, as requested by the law in force, are provided with technical documentation (electrical nameplate – datasheet – schematics – installation technical manual – software user manual) and with the CE Conformity Declarations.

The products are warranted free from defects in materials and workmanship, they comply with the features specified in their technical manuals and are repaired or replaced free of charge during the warranty period, as shown in the “Warranty Clause” contained in the “General Sales Conditions” on the next page.

DEA Security manufacture the products, make them comply with the security industry technical standards and supply them only to professional customers selected on the basis of the following objective criteria of a qualitative nature, *as far as new customers* are concerned:

- being an installation company working in the security industry mainly;

- having attended the above-mentioned technical training course organized by DEA Security at their facility in Italy.

The technical training course is an essential element for DEA Security to select the installation companies which are going to use DEA Security products for the first time. DEA Security issue a certificate of attendance to the customers which have attended the above-mentioned course.

DEA Security additional technical services purely aim at transferring the installation company the technical knowledge on Dea Security products and their installation procedures to obtain from them the best performance and the highest reliability.

Consequently, the feasibility project of DEA Security perimeter intrusion detection system and the installation of the latter pertain to and are under the responsibility of the installation company purchasing the products.

DEA Security have no other responsibility than the one relating to construction defects of DEA Security products, as specified in the “Warranty Clause” contained in the “General Sales Conditions” on the next page.

GENERAL SALES CONDITIONS

The Products and/or the Services offered by company

DEA SECURITY S.r.l. (hereinafter DEA Security)
Via Bolano, snc – 19037 Santo Stefano di Magra (SP) - Italy
VAT no.: IT00291080455

are provided according to the conditions below.

1. PREMISE

These General Sales Conditions shall be applicable to each purchase order. Should the Purchaser present in her/his order provisions which conflict with DEA SECURITY's General Sales Conditions, the latter shall prevail even in case DEA SECURITY fails to object to such provisions. By placing an order the Purchaser agrees with the present General Sales Conditions.

2. DELIVERY AND TRANSPORT

Unless otherwise agreed in writing between the parties, the delivery of the Products shall be carried out pursuant to the Incoterm EXW (Exworks) as defined in the INCOTERMS 2020 ICC. Therefore, DEA SECURITY's delivery obligations shall be limited to placing the Products, duly packed, at the purchaser's disposal at DEA SECURITY's warehouse located at Via Bolano snc – 19037 Santo Stefano di Magra (SP) - Italy.

Duties and costs related to the dispatch, carriage, insurance and customs clearance of the Products shall be entirely sustained by the customer, being the Products at the purchaser's risk and peril from the date of the placement by DEA SECURITY of the Products duly packed, and at the purchaser's disposal, in the above mentioned warehouse. The purchaser shall select at its own discretion the method and type of carriage which it shall, moreover, notify DEA SECURITY in writing in order to enable the same to suitably pack the goods.

Delivery times, even if specified in writing, are purely indicative.

DEA SECURITY shall not be liable for possible delays due to force majeure and events beyond its reasonable control.

For delays in delivering the goods, no penalty or claim for damages shall be applied to DEA SECURITY.

3. PRICES AND TECHNICAL FEATURES

All prices contained in our price list can be varied by DEA SECURITY at any moment without notice. Prices are gross prices (EXW S. Stefano di Magra - La Spezia - Italy) in Euro.

Any revision of DEA SECURITY's Price List annuls the previous edition.

4. USE OF THE PRODUCTS

The Products purchased must be used in accordance with the instructions contained in the relevant technical manuals and the laws in force.

5. CONDITIONS AND LIMITATIONS OF WARRANTY

The products manufactured by DEA SECURITY having operational defects under warranty shall be sent to DEA SECURITY's warehouse at Via Bolano, snc – 19037 Santo Stefano di Magra – La Spezia (Italy) at the purchaser's charge, where, upon verification of the existence of the claimed defect, they will be repaired or replaced under warranty with costs of shipment at the purchaser's charge. Please contact DEA SECURITY's technical department to obtain an RMA number prior to returning the goods.

The warranty shall not cover shortcomings due to mechanical breakdown also indirectly caused by a third party, short circuits, fires, lightnings, electrical and electrostatic discharges and any other event not depending on a physical defect of the Products.

The warranty shall not include those defects caused by improper handling, unauthorised modification or improper installation and/or use.

The warranty is not valid if payment has not been made in full within the agreed dates.

Any product defect shall be notified to DEA SECURITY by registered mail or by fax within 8 (eight) days from the discovery of the same, anyhow not beyond 6 (six) months from the delivery date.

The warranty is valid in all EU countries.

5.1 WARRANTY PERIOD

The Products manufactured by DEA Security which should have operational defects will be repaired or replaced under warranty pursuant to the following conditions:

INDOOR SYSTEMS

- period of warranty of 10 (ten) years as of the dispatch date shown on the delivery note for the sensors of SERIE A03 PRO;
- period of warranty of 3 (three) years as of the dispatch date shown on the delivery note for the cables and the electronic boards of SERIE A03 PRO and XENSITY, and for the sensors of SPC PRO and XENSITY;

OUTDOOR SYSTEMS

- period of warranty of 10 (ten) years as of the despatch date shown on the delivery note for the sensors and the sensor-strings of SERIR 50, SERIR COMPACT 50, TORSUS 50, TORSUS COMPACT 50 and SISMA CP 50 systems and for SISMA CA and SISMA CA PF sensor-modules;
- period of warranty of 5 (five) years as of the despatch date shown on the delivery note for FUSION and SERIR P2P sensors and sensor-strings;
- period of warranty of 3 (three) years, as of the despatch date shown on the delivery note for for all the connection cables, the junction/termination cases and the electronic boards;
- period of warranty of 1 (one) year as of the despatch date shown on the delivery note for the polyester cabinets, the backup batteries, the wiring kits and the stabilized power supply units (mark Adelsystem);
- period of warranty of 1 (one) year as of the despatch date shown on the delivery note for all the products contained in the section "Accessories".

6. PAYMENTS AND PROPERTY

The property of the products sold is transferred to the Purchaser only when payment has been made in full within the agreed dates.

If the purchaser fails to pay within the agreed date, DEA SECURITY shall be entitled to either suspend further deliveries or to cancel the order or part thereof, without prejudice to DEA SECURITY's entitlement to demand full payment for the goods already delivered at the time of cancellation and without prejudice to its right of compensation for loss and damage arising from cancellation.

In the event of late payment, DEA SECURITY shall be entitled to debit default interests in compliance with the provisions set forth by Legislative Decree 192/2012 and subsequent amendments and integrations.

7. DATA PROTECTION

In compliance with EU Regulation 2016/679, the Purchaser's personal data shall be collected for purposes related to the supply of goods and to the provision of a service, and treated in accordance with the information available at www.info679.eu/00291080455.

8. TECHNICAL ASSISTANCE

Unless otherwise agreed in writing between the Parties, on site technical assistance performed by DEA SECURITY's staff will be invoiced in compliance with the fares published by ANIE (Italian Association of Electrotechnical and Electronic Industries).

9. DISPUTE RESOLUTION

This agreement is governed by Italian Law.

Any legal dispute which may arise from the execution and/or interpretation of this agreement shall be under the exclusive competence of the court of Milan (Italy).

© 2024 DEA Security S.r.l.

DEA Security S.r.l. reserve the right to vary at any moment and without notice the information and the specifications herein.

All trademarks mentioned herein belong to their owners. Third-party brands, product names, trade names, corporate names and company names mentioned may be trademarks of their respective owners or registered trademarks of other companies and are used for purposes of explanation and to the owner's benefit, without implying a violation of copyright law.

PRODUCT CATALOGUE

2024



DEA Security S.r.l.
Via Bolano, snc - 19037 Santo Stefano di Magra (SP) - Italy
tel. +39 0187 699233 - fax +39 0187 697615
Vat no.: IT00291080455
www.deasecurity.com - dea@deasecurity.com

